

PRODUCT NUMBER

6 4 9 9 2 - X X X - X X X X LF

PLATING  
NOTE 12  
S= 15µm[0.38µm]GOLD/GXT  
ON CONTACT AREA  
100µm[2.54µm]PURE TIN  
ON TAIL  
G= 30µm[0.76µm]GOLD/GXT  
ON CONTACT AREA  
100µm[2.54µm]PURE TIN  
ON TAIL

LEAD FREE OPTION  
NOTE 9,11  
RETENTION  
R= RETENTION LEG  
NOTE 6  
POLARIZATION  
NOTE 8  
TAIL LENGTH  
5= .125/3.18  
POSITIONS PER ROW  
13 POS.

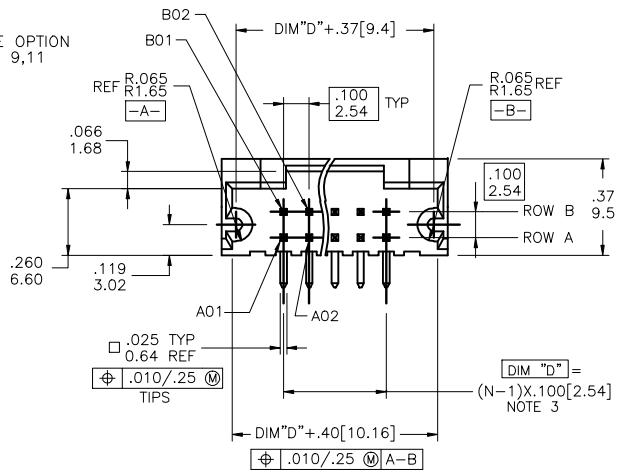

NOTES:

- ① HOUSING MAT'L: HIGH TEMPERATURE THERMOPLASTIC. UL94V-0  
COLOR: BLACK
- ② PIN MATERIAL: PHOSPHOR-BRONZE
- ③ TO DETERMINE DIMENSIONS:  
N= NUMBER OF POSITIONS PER ROW.  
EXAMPLE: 13 POS., (N-1)x.100/2.54=1.200/30.48
- ④ 3LBS./1.36 KG MIN. RETENTION IN EITHER DIRECTION.
- ⑤ PACKAGED IN TRAYS.
- ⑥ RETENTION LEG:  
5LB/2.3KG MAX INSERTION FORCE AND .25LB./1KG MIN RETENTION FORCE  
PER RETENTIVE PIN USING .062/1.57 THICK CIRCUIT BOARD AND RECOMMENDED  
HOLE PATTERN. RETENTIVE LOCATION AT THE DISCRETION OF THE MANUFACTURER.  
RETENTION IS TWO PINS PER PART ADJACENT TO ONE ANOTHER.  
IF FEATURE IS NOT APPLICABLE, REMOVE FROM PRODUCT NUMBER.
- ⑦ UNDER PLATING: .050µm/1.2µm Ni.
- ⑧ FOR POLARIZATION SPECIFY POSITION NUMBER (i.e., A03=ROW A POS. 3)  
TO OMIT PIN.  
IF FEATURE IS NOT APPLICABLE, REMOVE FROM PRODUCT NUMBER.
- ⑨ ADD "LF" SUFFIX AT THE END OF PART NUMBER FOR LEAD FREE  
OPTION.
- ⑩ THE HOUSING WILL WITHSTAND EXPOSURE TO 260°C PEAK TEMPERATURE  
FOR 15 SECONDS IN A WAVE SOLDER APPLICATION WITH A 1.5mm  
MINIMUM THICK CIRCUIT BOARD. SEE APPLICATION NOTES/PROCEDURES  
IF THEY ARE AVAILABLE.
- ⑪ THIS PRODUCT MEETS EUROPEAN UNION DIRECTIVES AND OTHER  
COUNTRY REGULATION AS DESCRIBED IN GS-22-008.
- ⑫ PLATING OPTIONS:  
MAY BE EITHER GOLD OR GXT PLATED AT MANUFACTURER'S OPTION.

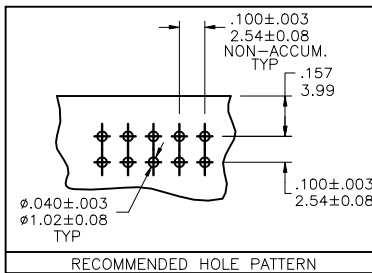
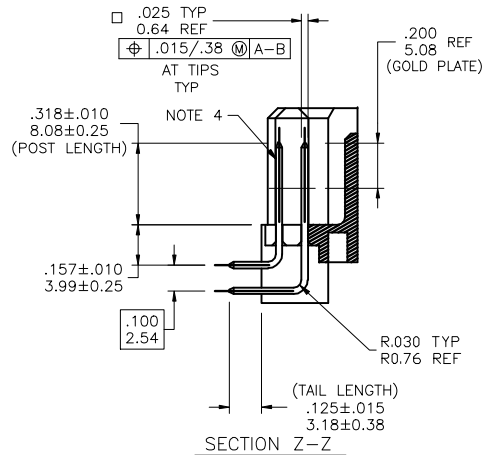
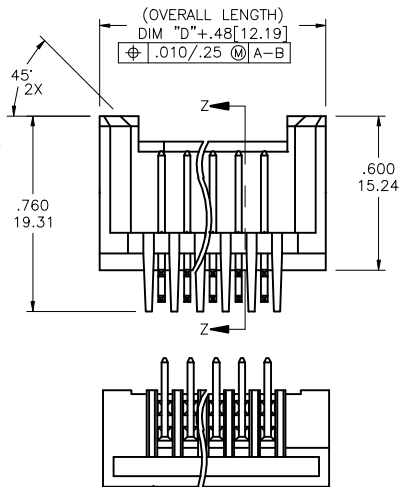

|             |          |                                |          |                                       |                     |                       |  |                               |  |
|-------------|----------|--------------------------------|----------|---------------------------------------|---------------------|-----------------------|--|-------------------------------|--|
| mat'l. code |          | surface<br>ISO 406<br>ISO 1302 |          | tolerance<br>ISO 406<br>ISO 1301      |                     | projection<br>INCH/MM |  | product family<br>HEADER      |  |
| ltr         | ecn no   | dr                             | date     | tolerances unless otherwise specified |                     | title                 |  | title                         |  |
| C           | M05-0220 | MHT                            | 10/20/05 | angles                                | .XX±.01/XX±0.3      | .100/2.54mm GUIDE PIN |  | SHROUDED R/A HEADER           |  |
| D           | M07-0116 | AGS                            | 2/19/07  | linear                                | .XXX±.006/XXX±0.13  | scale 1:1             |  | dwg no 64992                  |  |
| E           | M07-0248 | MHT                            | 5/30/07  | 0'±2'                                 | .XXX±.0020/XXX±0.05 | scale 1:1             |  | sheet 1 of 1 size A3          |  |
| F           | M09-0059 | MHT                            | 4/16/09  | dr                                    | O. INGRAM           | 6/23/99               |  | type Product Customer Drawing |  |
| G           | M09-0099 | MHT                            | 7/06/09  | engr                                  | H. SUNDY            | 7/12/99               |  |                               |  |
| H           | M09-0136 | MHT                            | 9/03/09  | chr                                   | H. SUNDY            | 7/12/99               |  |                               |  |
| J           | M09-0154 | MHT                            | 9/10/09  | appd                                  | H. SUNDY            | 7/12/99               |  |                               |  |
| sheet       | revision | J                              |          |                                       |                     |                       |  |                               |  |
| index       | sheet    | 1                              |          |                                       |                     |                       |  |                               |  |