

HIGH SPEED 128K x 8 DUAL CHIP ENABLE CMOS STATIC RAM

FEATURES

- High Speed (Equal Access and Cycle Times)
 - 15/20/25/35 ns (Commercial)
 - 20/25/35/45 ns (Industrial)
 - 20/25/35/45/55/70/85/100/120 ns (Military)
- Single 5 Volts $\pm 10\%$ Power Supply
- Easy Memory Expansion Using CE_1 , CE_2 and OE Inputs
- Common Data I/O
- Three-State Outputs
- Fully TTL Compatible Inputs and Outputs

- Advanced CMOS Technology
- Fast t_{OE}
- Automatic Power Down
- Packages
 - 32-Pin 300 mil DIP and SOJ
 - 32-Pin 400 mil SOJ
 - 32-Pin 600 mil Ceramic DIP
 - 32-Pin 400 mil Ceramic DIP
 - 32-Pin Solder Seal Flatpack
 - 32-Pin LCC (450 x 550 mil)
 - 32-Pin Ceramic SOJ

DESCRIPTION

The FT61024 is a 1,048,576-bit high-speed CMOS static RAM organised as 128Kx8. The CMOS memory requires no clocks or refreshing, and has equal access and cycle times. Inputs are fully TTL-compatible. The RAM operates from a single 5V $\pm 10\%$ tolerance power supply.

Access times of 15 nanoseconds permit greatly enhanced system operating speeds. CMOS is utilised to reduce power consumption to a low level. The FT61024 is a member of a family of Force Ram products offering fast access times.

The FT61024 device provides asynchronous operations with matching access and cycle times. Memory locations are specified on address pins A_0 to A_{16} . Reading is accomplished by device selection (CE_1 low and CE_2 high) and output enabling (OE) while write enable (WE) remains HIGH. By presenting the address under these conditions, the data in the addressed memory location is presented on the data input/output pins. The input/output pins stay in the HIGH Z state when either CE_1 or OE is HIGH or WE or CE_2 is LOW.

FUNCTIONAL BLOCK DIAGRAM

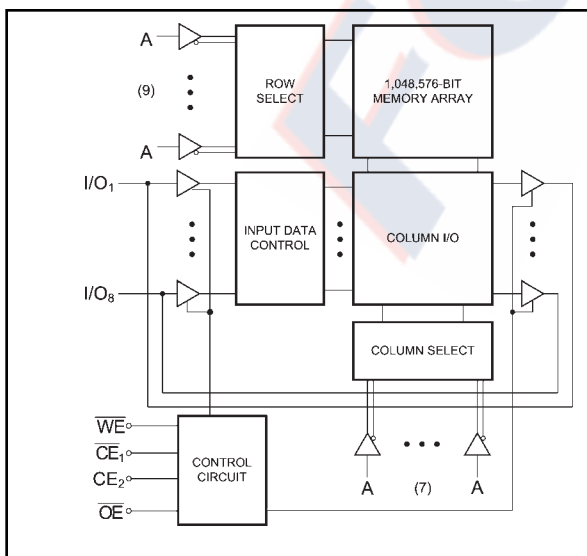

PIN CONFIGURATION

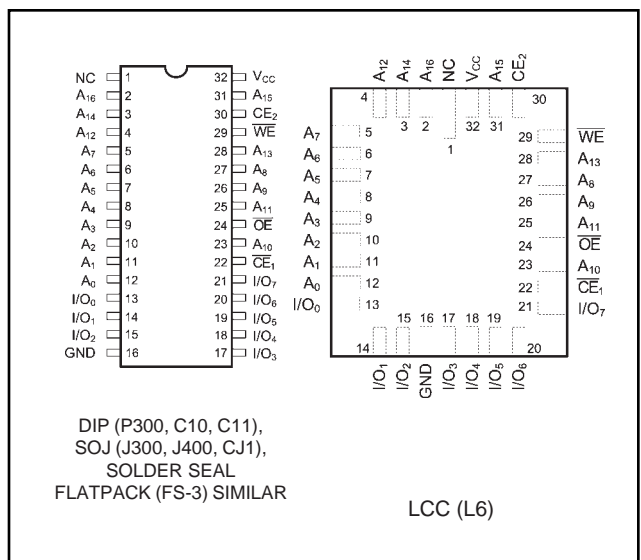

MAXIMUM RATINGS⁽¹⁾

Symbol	Parameter	Value	Unit
V_{CC}	Power Supply Pin with Respect to GND	-0.5 to +7	V
V_{TERM}	Terminal Voltage with Respect to GND (up to 7.0V)	-0.5 to $V_{CC} + 0.5$	V
T_A	Operating Temperature	-55 to +125	°C

RECOMMENDED OPERATING TEMPERATURE AND SUPPLY VOLTAGE

Grade ⁽²⁾	Ambient Temperature	GND	V_{CC}
Military	-55°C to +125°C	0V	5.0V ± 10%
Industrial	-40°C to +85°C	0V	5.0V ± 10%
Commercial	0°C to +70°C	0V	5.0V ± 10%

DC ELECTRICAL CHARACTERISTICS

Over recommended operating temperature and supply voltage⁽²⁾

Symbol	Parameter	Test Conditions	FT61024		FT61024L		Unit
			Min	Max	Min	Max	
V_{IH}	Input High Voltage		2.2	$V_{CC} + 0.5$	2.2	$V_{CC} + 0.5$	V
V_{IL}	Input Low Voltage		-0.5 ⁽³⁾	0.8	-0.5 ⁽³⁾	0.8	V
V_{HC}	CMOS Input High Voltage		$V_{CC} - 0.2$	$V_{CC} + 0.5$	$V_{CC} - 0.2$	$V_{CC} + 0.5$	V
V_{LC}	CMOS Input Low Voltage		-0.5 ⁽³⁾	0.2	-0.5 ⁽³⁾	0.2	V
V_{CD}	Input Clamp Diode Voltage	$V_{CC} = \text{Min.}, I_{IN} = -18 \text{ mA}$		-1.2		-1.2	V
V_{OL}	Output Low Voltage (TTL Load)	$I_{OL} = +8 \text{ mA}, V_{CC} = \text{Min.}$		0.4		0.4	V
V_{OH}	Output High Voltage (TTL Load)	$I_{OH} = -4 \text{ mA}, V_{CC} = \text{Min.}$	2.4		2.4		V
I_{LI}	Input Leakage Current	$V_{CC} = \text{Max.}$ Mil.	-10	+10	-5	+5	μA
		$V_{IN} = \text{GND to } V_{CC}$ Ind./Com'l.	-5	+5	n/a	n/a	
I_{LO}	Output Leakage Current	$V_{CC} = \text{Max.}, CE = V_{IH}$ Mil.	-10	+10	-5	+5	μA
		$V_{OUT} = \text{GND to } V_{CC}$ Ind./Com'l.	-5	+5	n/a	n/a	
I_{SB}	Standby Power Supply Current (TTL Input Levels)	$CE_1 \geq V_{IH}$ or Mil.	—	35	—	25	mA
		$CE_2 \leq V_{IL}$, Ind./Com'l.	—	30	—	n/a	
I_{SB1}	Standby Power Supply Current (CMOS Input Levels)	$CE_1 \geq V_{HC}$ or Mil.	—	25	—	2	mA
		$CE_2 \leq V_{LC}$, Ind./Com'l.	—	20	—	n/a	
		$V_{CC} = \text{Max.}, f = \text{Max.}, \text{Outputs Open}$					
		$V_{IN} \leq V_{LC}$ or $V_{IN} \geq V_{HC}$					

Notes:

1. Stresses greater than those listed under MAXIMUM RATINGS may cause permanent damage to the device. This is a stress rating only and functional operation of the device at these or any other conditions above those indicated in the operational sections of this specification is not implied. Exposure to MAXIMUM rating conditions for extended

periods may affect reliability.

- Extended temperature operation guaranteed with 400 linear feet per minute of air flow.
- Transient inputs with V_{IL} and I_{IL} not more negative than -3.0V and -100mA, respectively, are permissible for pulse widths up to 20ns.
- This parameter is sampled and not 100% tested.

CAPACITANCES⁽⁴⁾

$V_{CC} = 5.0\text{V}, T_A = 25^\circ\text{C}, f = 1.0\text{MHz}$

Symbol	Parameter	Conditions	Typ.	Unit
C_{IN}	Input Capacitance	$V_{IN} = 0\text{V}$	8	pF
C_{OUT}	Output Capacitance	$V_{OUT} = 0\text{V}$	10	pF

HIGH SPEED 128K x 8 DUAL CHIP ENABLE CMOS STATIC RAM

POWER DISSIPATION CHARACTERISTICS VS. SPEED

Symbol	Parameter	Temperature Range	-15	-20	-25	-35	-45	-55	-70	-85	-100	-120	Unit
I_{CC}	Dynamic Operating Current*	Commercial	190	160	150	145	N/A	N/A	N/A	N/A	N/A	N/A	mA
		Industrial	N/A	175	165	160	155	N/A	N/A	N/A	N/A	N/A	mA
		Military	N/A	150	140	135	130	125	115	110	105	100	mA

* $V_{CC} = 5.5V$. Tested with outputs open. $f = \text{Max}$. Switching inputs are 0V and 3V. $CE_1 = V_{IL}$, $CE_2 = V_{IH}$, $OE = V_{IH}$

DATA RETENTION CHARACTERISTICS (FT61024L, Military Temperature Only)

Symbol	Parameter	Test Condition	Min	Typ.*		Max		Unit
				$V_{CC} = 2.0V$	$V_{CC} = 3.0V$	$V_{CC} = 2.0V$	$V_{CC} = 3.0V$	
V_{DR}	V_{CC} for Data Retention		2.0					V
I_{CCDR}	Data Retention Current	$CE_1 \geq V_{CC} - 0.2V$ or		50	200	400	600	μA
t_{CDR}	Chip Deselect to Data Retention Time	$CE_2 \leq 0.2V$, $V_{IN} \geq V_{CC} - 0.2V$ or $V_{IN} \leq 0.2V$						ns
t_R^\dagger	Operation Recovery Time		t_{RC}^{\S}					ns

* $T_A = +25^\circ C$

$\S t_{RC}$ = Read Cycle Time

\dagger This parameter is guaranteed but not tested.

DATA RETENTION WAVEFORM

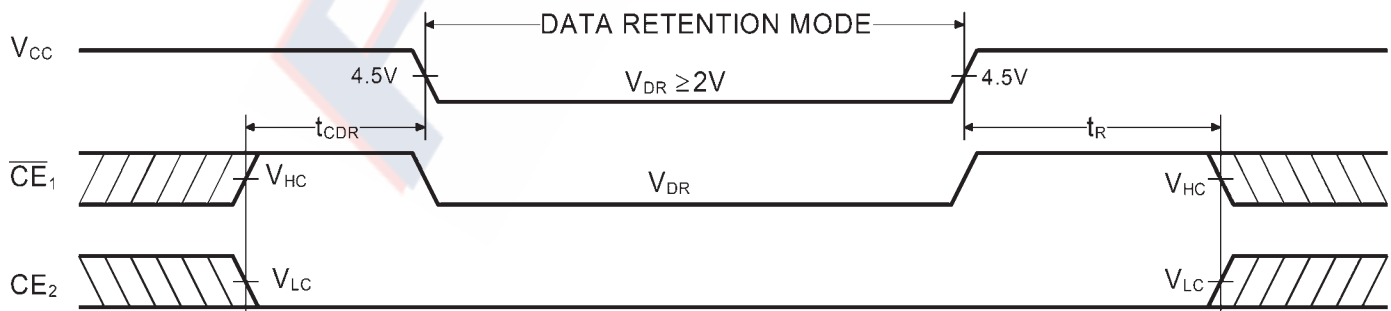

AC ELECTRICAL CHARACTERISTICS—READ CYCLE

($V_{CC} = 5V \pm 10\%$, All Temperature Ranges)⁽²⁾

Symbol	Parameter	-15		-20		-25		-35		-45		-55		-70		-85		-100		-120		Unit
		Min	Max	Min	Max	Min	Max	Min	Max	Min	Max	Min	Max	Min	Max	Min	Max	Min	Max	Min	Max	
t_{RC}	Read Cycle Time	15		20		25		35		45		55		70		85		100		120		ns
t_{AA}	Address Access Time		15		20		25		35		45		55		70		85		100		120	ns
t_{AC}	Chip Enable Access Time		15		20		25		35		45		55		70		85		100		120	ns
t_{OH}	Output Hold from Address Change	3		3		3		3		3		3		3		3		3		3		ns
t_{LZ}	Chip Enable to Output in Low Z	3		3		3		3		3		3		3		3		3		3		ns
t_{HZ}	Chip Disable to Output in High Z		8		9		11		15		20		25		30		35		40		50	ns
t_{OE}	Output Enable Low to Data Valid		7		9		11		15		20		25		30		35		40		50	ns
t_{OLZ}	Output Enable Low to Low Z	0		0		0		0		0		0		0		0		0		0		ns
t_{OHZ}	Output Enable High to High Z		7		9		11		15		20		25		30		35		40		50	ns
t_{PU}	Chip Enable to Power Up Time	0		0		0		0		0		0		0		0		0		0		ns
t_{PD}	Chip Disable to Power Down Time		12		20		20		20		25		30		35		40		45		50	ns

TIMING WAVEFORM OF READ CYCLE NO. 1 (OE CONTROLLED)⁽⁵⁾

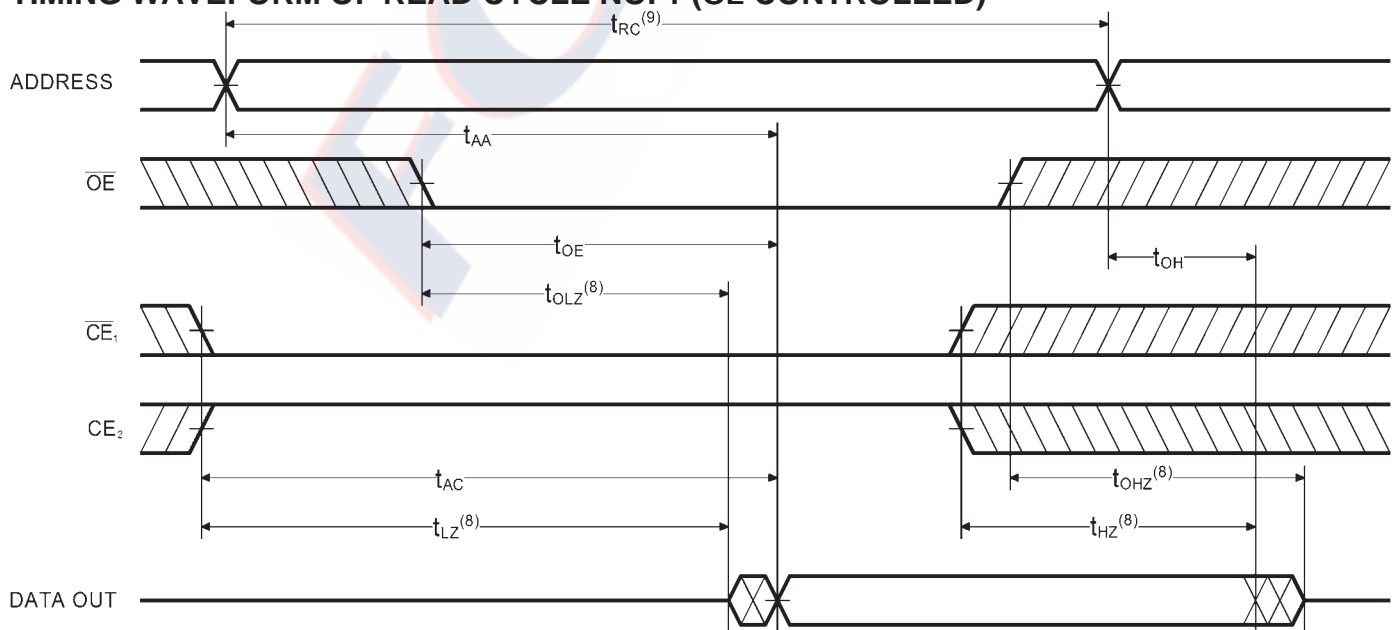

Notes:

- WE is HIGH for READ cycle.
- CE_1 is LOW, CE_2 is HIGH and OE is LOW for READ cycle.
- ADDRESS must be valid prior to, or coincident with CE_1 transition LOW and CE_2 transition HIGH.

- Transition is measured ± 200 mV from steady state voltage prior to change, with loading as specified in Figure 1. This parameter is sampled and not 100% tested.

**HIGH SPEED 128K x 8
DUAL CHIP ENABLE
CMOS STATIC RAM**

TIMING WAVEFORM OF READ CYCLE NO. 2 (ADDRESS CONTROLLED)^(5,6)

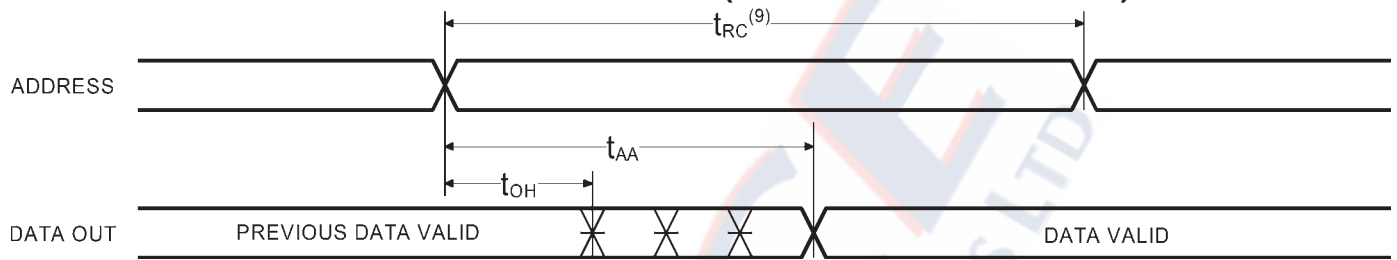

TIMING WAVEFORM OF READ CYCLE NO. 3 (CE₁, CE₂ CONTROLLED)^(5,7,10)

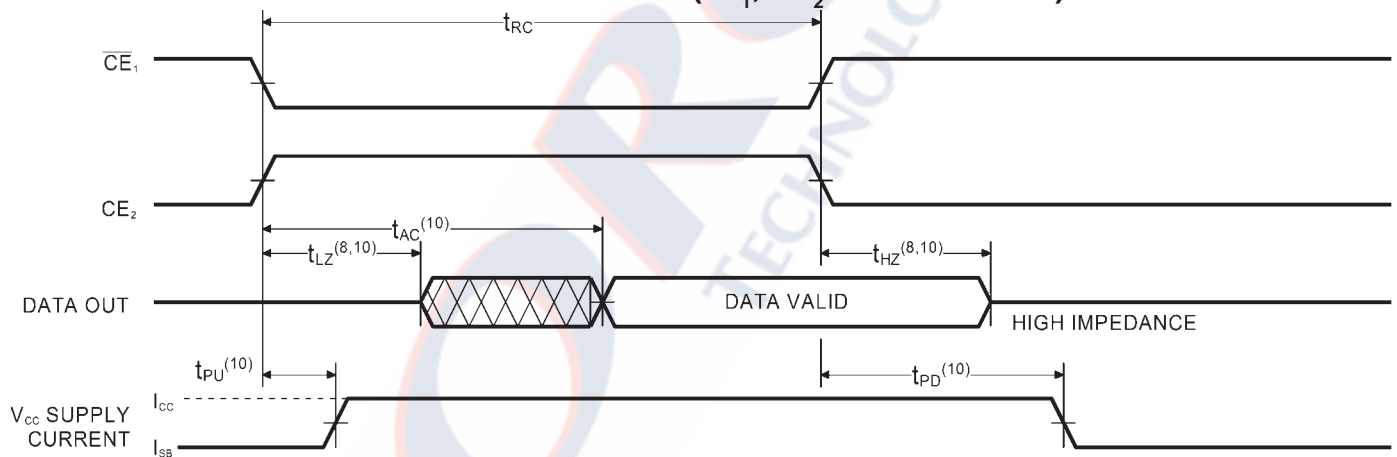

Notes:

9. READ Cycle Time is measured from the last valid address to the first transitioning address.

10. Transitions caused by a chip enable control have similar delays irrespective of whether CE_1 or CE_2 causes them.

AC CHARACTERISTICS—WRITE CYCLE

($V_{CC} = 5V \pm 10\%$, All Temperature Ranges)⁽²⁾

Symbol	Parameter	-15		-20		-25		-35		-45		-55		-70		-85		-100		-120		Unit
		Min	Max	Min	Max	Min	Max	Min	Max	Min	Max	Min	Max	Min	Max	Min	Max	Min	Max	Min	Max	
t_{WC}	Write Cycle Time	15		20		25		35		45		55		70		85		100		120		ns
t_{CW}	Chip Enable Time to End of Write	12		15		18		22		30		35		45		50		60		75		ns
t_{AW}	Address Valid to End of Write	12		15		20		25		35		45		60		70		85		100		ns
t_{AS}	Address Set-up Time	0		0		0		0		0		0		0		0		0		0		ns
t_{WP}	Write Pulse Width	12		15		18		22		25		30		40		45		55		70		ns
t_{AH}	Address Hold Time	0		0		0		0		0		0		0		0		0		0		ns
t_{DW}	Data Valid to End of Write	7		8		10		15		20		25		30		35		45		60		ns
t_{DH}	Date Hold Time	0		0		0		0		0		0		0		0		0		0		ns
t_{WZ}	Write Enable to Output in High Z		8		10		11		15		18		20		25		30		40		50	ns
t_{OW}	Output Active from End of Write	3		3		3		3		3		3		3		3		3		3		ns

TIMING WAVEFORM OF WRITE CYCLE NO. 1 (WE CONTROLLED)⁽¹¹⁾

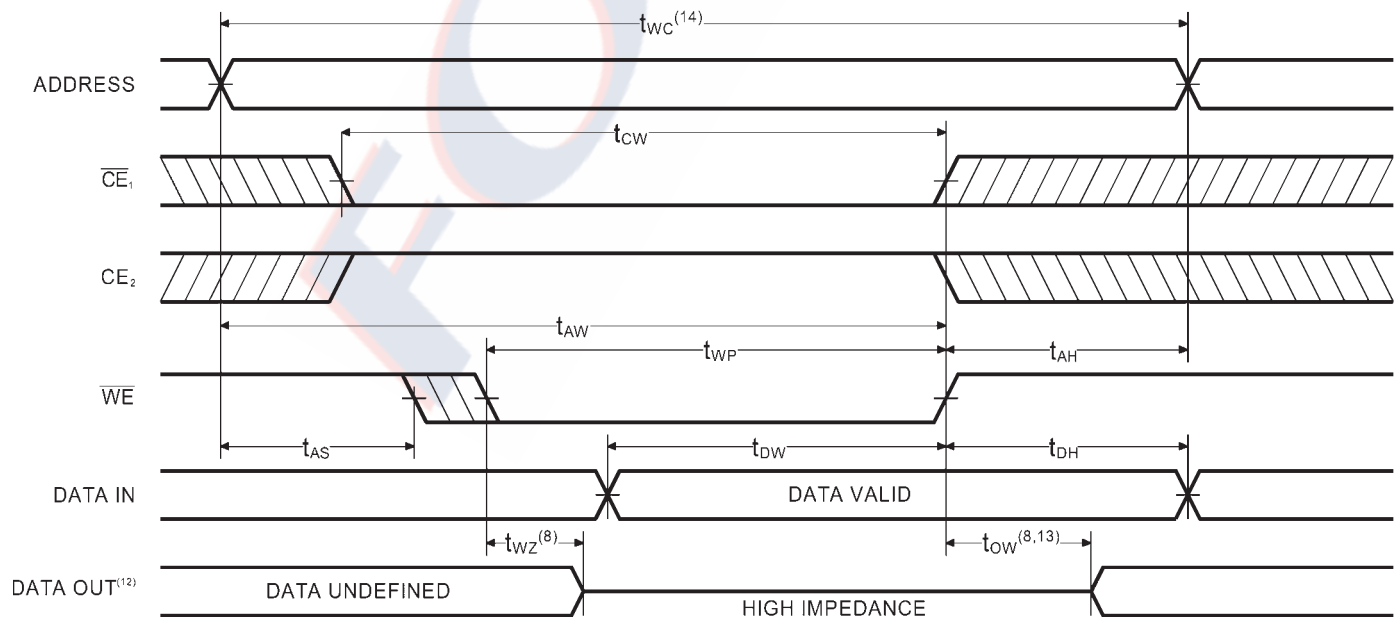

Notes:

11. CE₁ and WE must be LOW, and CE₂ HIGH for WRITE cycle.
12. OE is LOW for this WRITE cycle to show t_{WZ} and t_{OW} .
13. If CE₁ goes HIGH, or CE₂ goes LOW, simultaneously with WE HIGH, the output remains in a high impedance state.

14. Write Cycle Time is measured from the last valid address to the first transitioning address.

TIMING WAVEFORM OF WRITE CYCLE NO. 2 (CE CONTROLLED)⁽¹¹⁾

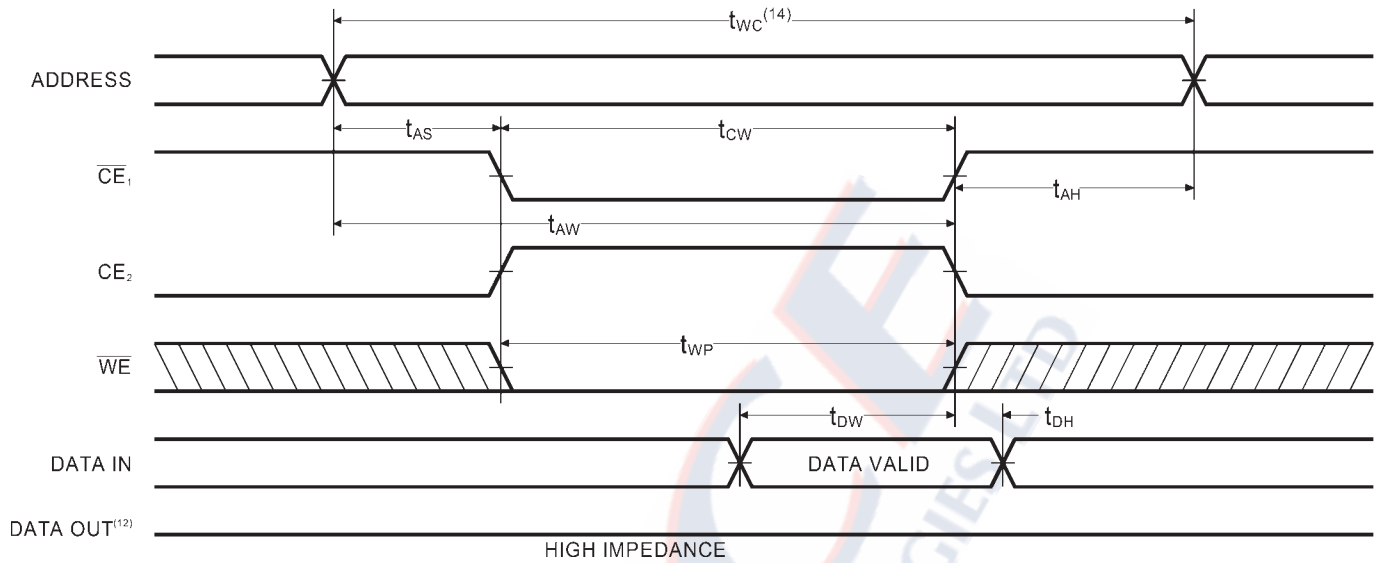

AC TEST CONDITIONS

Input Pulse Levels	GND to 3.0V
Input Rise and Fall Times	3ns
Input Timing Reference Level	1.5V
Output Timing Reference Level	1.5V
Output Load	See Fig. 1 and 2

TRUTH TABLE

Mode	CE ₁	CE ₂	OE	WE	I/O	Power
Standby	H	X	X	X	High Z	Standby
Standby	X	L	X	X	High Z	Standby
D _{OUT} Disabled	L	H	H	H	High Z	Active
Read	L	H	L	H	D _{OUT}	Active
Write	L	H	X	L	High Z	Active

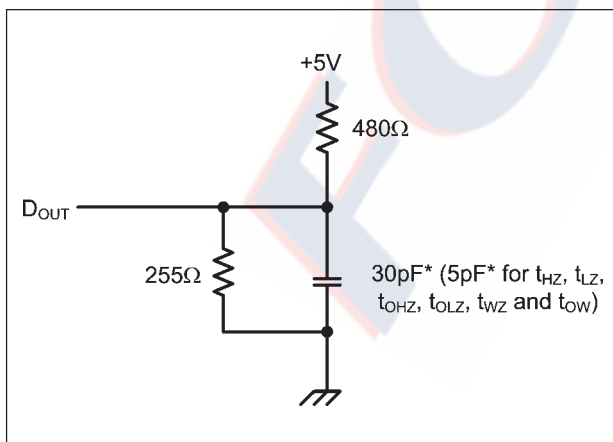

Figure 1. Output Load

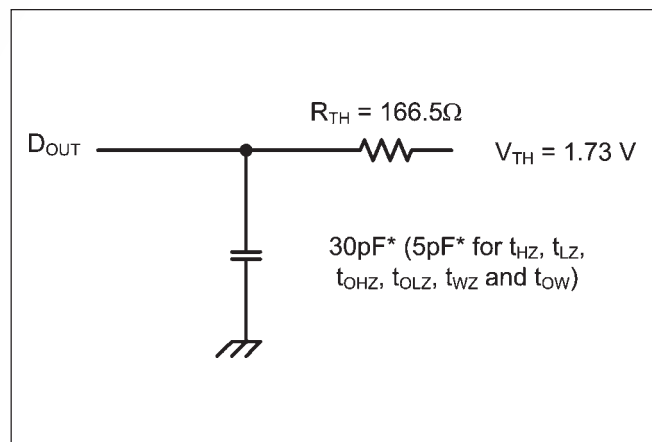

Figure 2. Thevenin Equivalent

* including scope and test fixture.

Note:

Because of the ultra-high speed of the FT61024, care must be taken when testing this device; an inadequate setup can cause a normal functioning part to be rejected as faulty. Long high-inductance leads that cause supply bounce must be avoided by bringing the V_{CC} and ground planes directly up to the contactor fingers. A 0.01 μF high frequency capacitor is also required between V_{CC} and ground.

To avoid signal reflections, proper termination must be used; for example, a 50Ω test environment should be terminated into a 50Ω load with 1.73V (Thevenin Voltage) at the comparator input, and a 116Ω resistor must be used in series with D_{OUT} to match 166Ω (Thevenin Resistance).

**HIGH SPEED 128K x 8
DUAL CHIP ENABLE
CMOS STATIC RAM**

Ordering Information

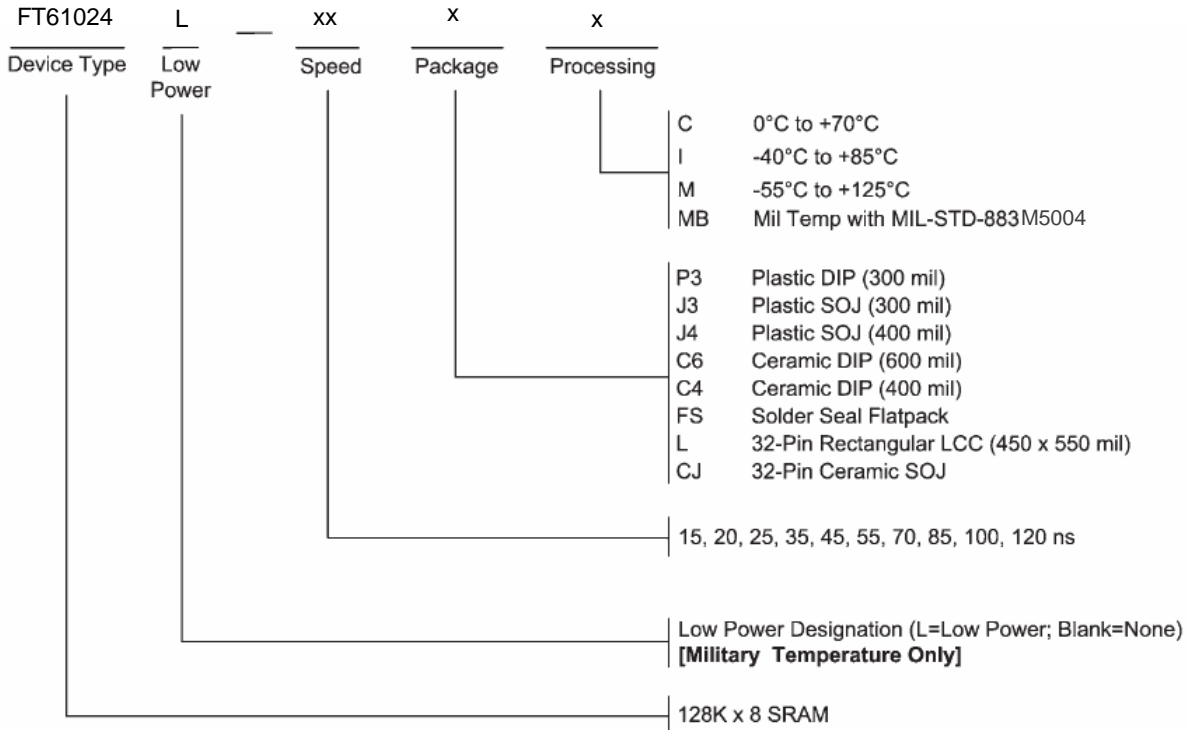

SELECTION GUIDE

The FT61024 is available in the following temperature, speed and package options.

Temperature Range	Package	Speed				
		15	20	25	35	45
Commercial	Plastic DIP (300 mil)	-15P3C	-20P3C	-25P3C	-35P3C	N/A
	Plastic SOJ (300 mil)	-15J3C	-20J3C	-25J3C	-35J3C	N/A
	Plastic SOJ (400 mil)	-15J4C	-20J4C	-25J4C	-35J4C	N/A
Industrial	Plastic DIP (300 mil)	N/A	-20P3I	-25P3I	-35P3I	-45P3I
	Plastic SOJ (300 mil)	N/A	-20J3I	-25J3I	-35J3I	-45J3I
	Plastic SOJ (400 mil)	N/A	-20J4I	-25J4I	-35J4I	-45J4I
Military Temperature	Ceramic DIP (600 mil)	N/A	-20C6M	-25C6M	-35C6M	-45C6M
	Ceramic DIP (400 mil)	N/A	-20C4M	-25C4M	-35C4M	-45C4M
	Solder Seal Flatpack	N/A	-20FSM	-25FSM	-35FSM	-45FSM
	LCC (450 x 550 mil)	N/A	-20LM	-25LM	-35LM	-45LM
	Ceramic SOJ	N/A	-20CJM	-25CJM	-35CJM	-45CJM
Military Processed*	Ceramic DIP (600 mil)	N/A	-20C6MB	-25C6MB	-35C6MB	-45C6MB
	Ceramic DIP (400 mil)	N/A	-20C4MB	-25C4MB	-35C4MB	-45C4MB
	Solder Seal Flatpack	N/A	-20FSMB	-25FSMB	-35FSMB	-45FSMB
	LCC (450 x 550 mil)	N/A	-20LMB	-25LMB	-35LMB	-45LMB
	Ceramic SOJ	N/A	-20CJMB	-25CJMB	-35CJMB	-45CJMB

* Military temperature range with MIL-STD-883 M5004
N/A = Not Available

**HIGH SPEED 128K x 8
DUAL CHIP ENABLE
CMOS STATIC RAM**

Temperature Range	Package	Speed				
		55	70	85	100	120
Commercial	Plastic DIP (300 mil)	N/A	N/A	N/A	N/A	N/A
	Plastic SOJ (300 mil)	N/A	N/A	N/A	N/A	N/A
	Plastic SOJ (400 mil)	N/A	N/A	N/A	N/A	N/A
Industrial	Plastic DIP (300 mil)	N/A	N/A	N/A	N/A	N/A
	Plastic SOJ (300 mil)	N/A	N/A	N/A	N/A	N/A
	Plastic SOJ (400 mil)	N/A	N/A	N/A	N/A	N/A
Military Temperature	Ceramic DIP (600 mil)	-55C6M	-70C6M	-85C6M	-100C6M	-120C6M
	Ceramic DIP (400 mil)	-55C4M	-70C4M	-85C4M	-100C4M	-120C4M
	Solder Seal Flatpack	-55FSM	-70FSM	-85FSM	-100FSM	-120FSM
	LCC (450 x 550 mil)	-55LM	-70LM	-85LM	-100LM	-120LM
	Ceramic SOJ	-55CJM	-70CJM	-85CJM	-100CJM	-120CJM
Military Processed*	Ceramic DIP (600 mil)	-55C6MB	-70C6MB	-85C6MB	-100C6MB	-120C6MB
	Ceramic DIP (400 mil)	-55C4MB	-70C4MB	-85C4MB	-100C4MB	-120C4MB
	Solder Seal Flatpack	-55FSMB	-70FSMB	-85FSMB	-100FSMB	-120FSMB
	LCC (450 x 550 mil)	-55LMB	-70LMB	-85LMB	-100LMB	-120LMB
	Ceramic SOJ	-55CJMB	-70CJMB	-85CJMB	-100CJMB	-120CJMB

* Military temperature range with MIL-STD-883 M5004
N/A = Not Available

**HIGH SPEED 128K x 8
DUAL CHIP ENABLE
CMOS STATIC RAM**

Pkg #	J300	
# Pins	32 (300 mil)	
Symbol	Min	Max
A	0.128	0.148
A1	0.082	-
b	0.016	0.020
C	0.007	0.010
D	0.820	0.830
e	0.050 BSC	
E	0.335 BSC	
E1	0.295	0.305
E2	0.267 BSC	
Q	0.025	-

SOJ SMALL OUTLINE IC PACKAGE (300 mil)

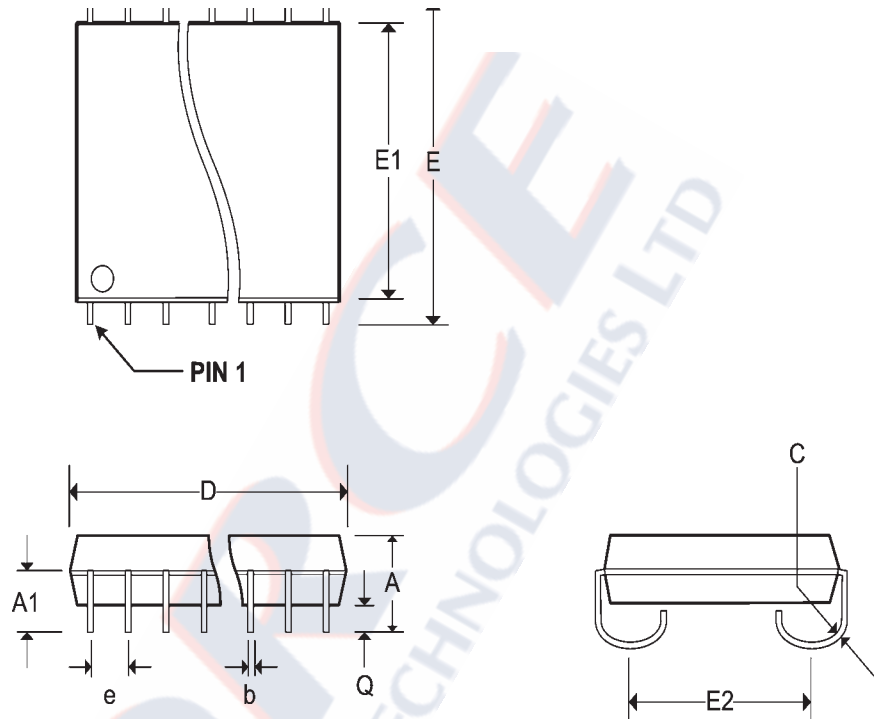

Pkg #	J400	
# Pins	32 (400 mil)	
Symbol	Min	Max
A	0.128	0.148
A1	0.082	-
b	0.015	0.020
C	0.007	0.013
D	0.820	0.830
e	0.050 BSC	
E	0.435	0.445
E1	0.395	0.405
E2	0.370 BSC	
Q	0.025	-

SOJ SMALL OUTLINE IC PACKAGE (400 mil)

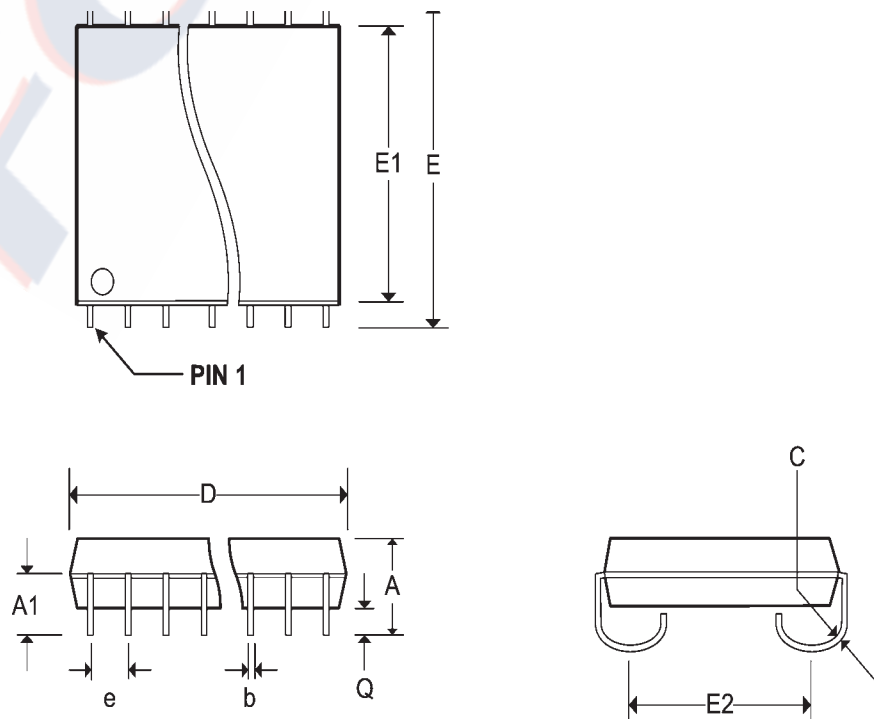

Pkg #	P300	
# Pins	32 (300 mil)	
Symbol	Min	Max
A	-	0.200
A1	0.015	-
b	0.014	0.022
b2	0.048	0.054
C	0.008	0.014
D	1.580	1.620
E1	0.270	0.300
E	0.300	0.310
e	0.100 BSC	
eB	0.320	0.390
L	0.120	0.140
α	0°	15°

PLASTIC DUAL IN-LINE PACKAGE

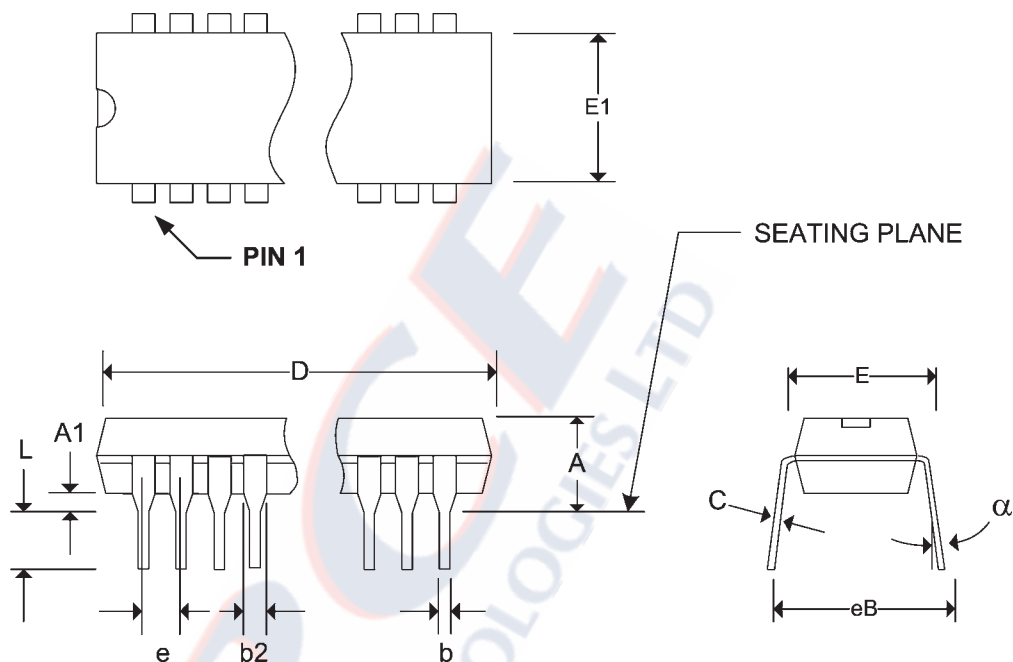

Pkg #	FS-3	
# Pins	32	
Symbol	Min	Max
A	0.097	0.125
b	0.015	0.019
c	0.003	0.009
D	-	0.830
E	0.400	0.420
E1	-	0.450
E2	0.180	-
E3	0.030	-
e	0.050 BSC	
L	0.250	0.370
Q	0.020	0.045
S	-	0.045
S1	0.000	-
M	-	0.0015
N	32	

SOLDER SEAL FLAT PACKAGE

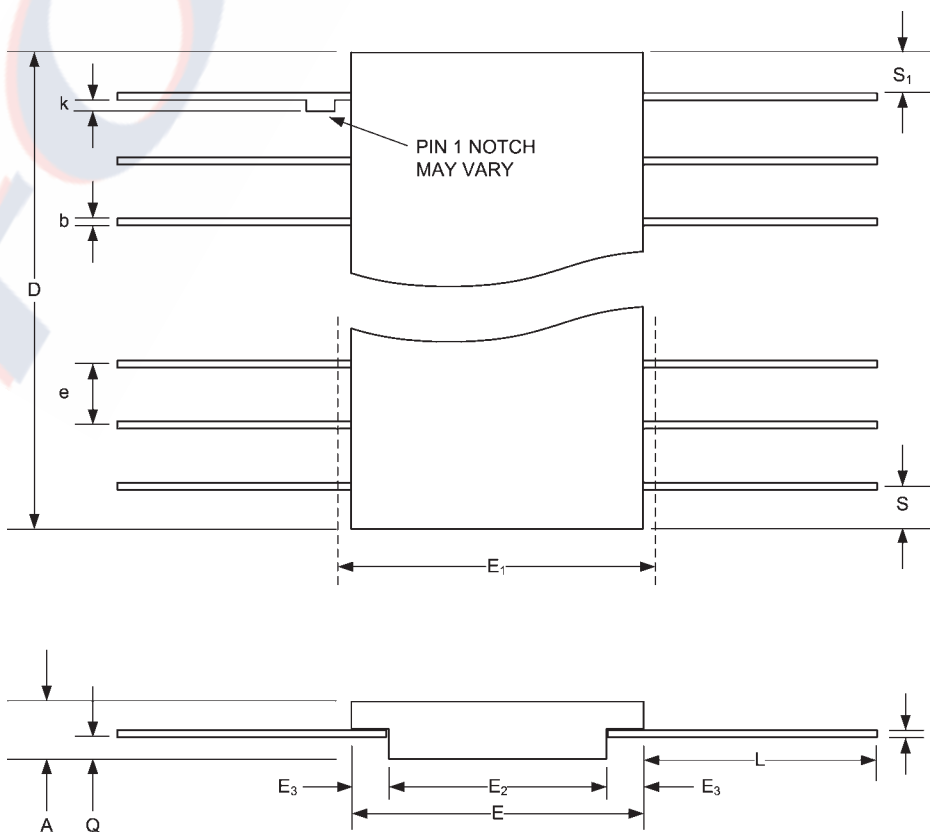

Pkg #	C10	
# Pins	32 (600 mil)	
Symbol	Min	Max
A	-	0.225
b	0.014	0.026
b2	0.045	0.065
C	0.008	0.018
D	-	1.680
E	0.510	0.620
eA	0.600 BSC	
e	0.100 BSC	
L	0.125	0.200
Q	0.015	0.070
S1	0.005	-
S2	0.005	-

SIDEBRAZED DUAL IN-LINE PACKAGE (600 mil)

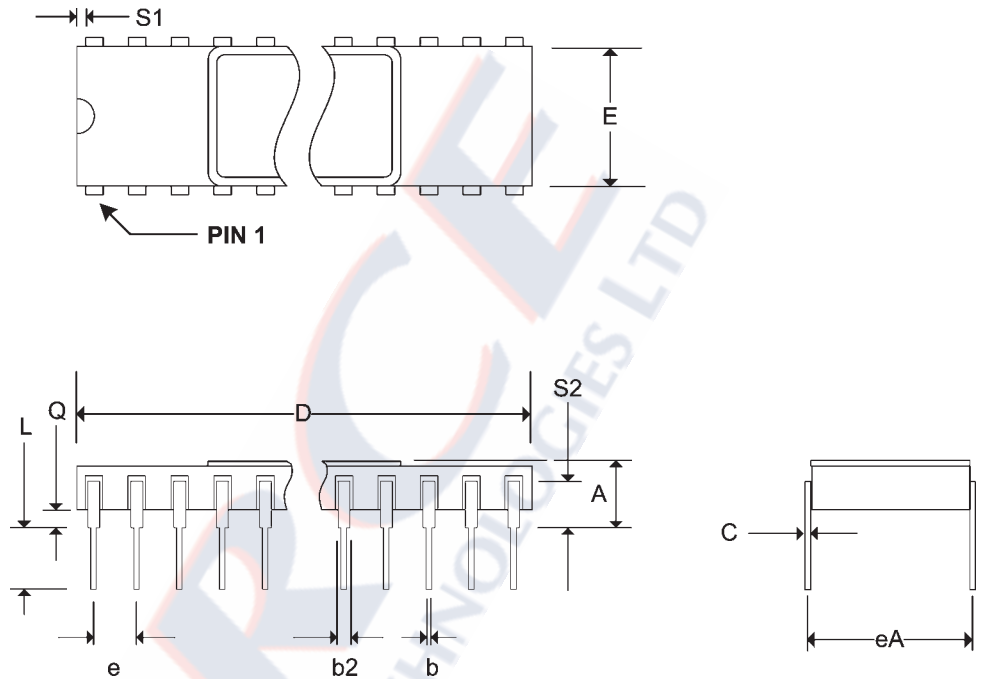

Pkg #	C11	
# Pins	32 (400 mil)	
Symbol	Min	Max
A	-	0.232
b	0.014	0.023
b2	0.038	0.065
C	0.008	0.018
D	-	1.700
E	0.350	0.410
eA	0.400 BSC	
e	0.100 BSC	
L	0.125	0.200
Q	0.015	0.060
S1	0.005	-
S2	0.005	-

SIDEBRAZED DUAL IN-LINE PACKAGE (400 mil)

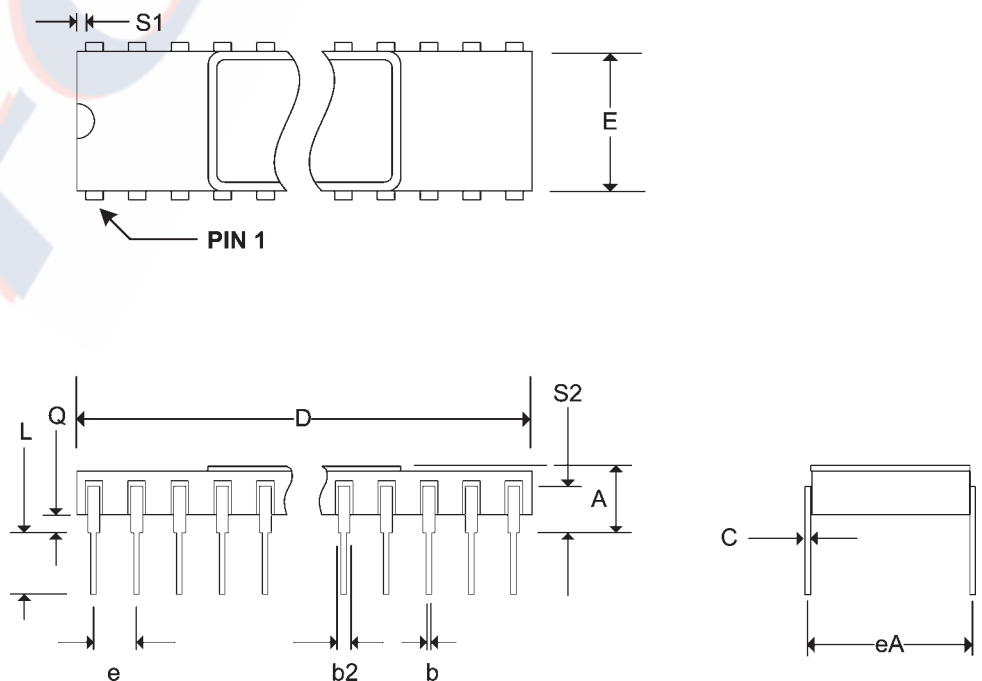

Pkg #	L6	
# Pins	32	
Symbol	Min	Max
A	0.060	0.075
A1	0.050	0.065
B1	0.022	0.028
D	0.442	0.458
D1	0.300 BSC	
D2	0.150 BSC	
D3	-	0.458
E	0.540	0.560
E1	0.400 BSC	
E2	0.200 BSC	
E3	-	0.558
e	0.050 BSC	
h	0.040 REF	
j	0.020 REF	
L	0.045	0.055
L1	0.045	0.055
L2	0.075	0.095
ND	7	
NE	9	

RECTANGULAR LEADLESS CHIP CARRIER

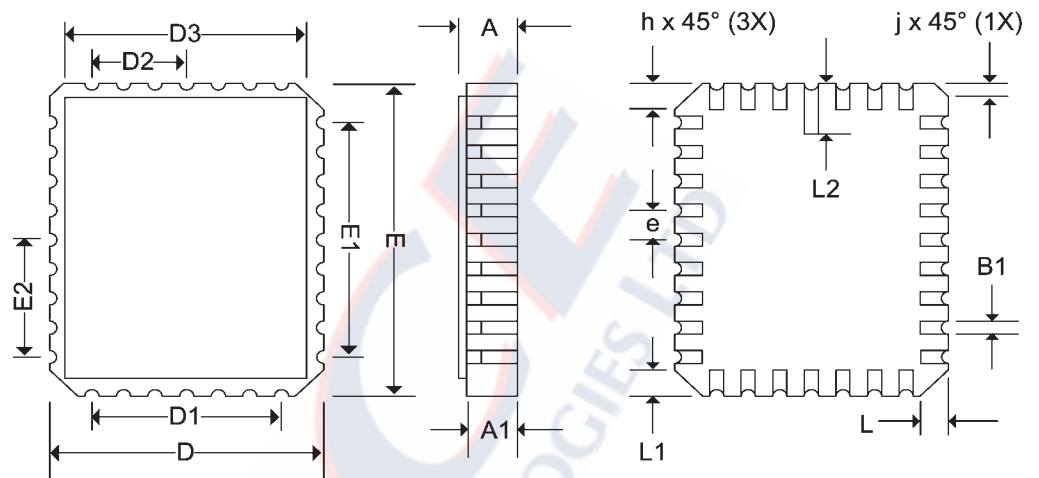

Pkg #	CJ1	
# Pins	32	
Symbol	Min	Max
A	0.120	0.165
A1	0.088	0.120
A2	0.070	REF
B	0.010	REF
B1	0.030R	TYP
B2	0.020	REF
B3	0.025	0.045
D	0.816	0.838
D1	0.750	REF
E	0.419	0.431
E1	0.430	0.445
E2	0.360	0.380
e	0.050 BSC	
e1	0.038	TYP
e2	0.005	
j	0.005	TYP
S	0.030	0.040
S1	0.020	TYP

CERAMIC SOJ SMALL OUTLINE IC PACKAGE

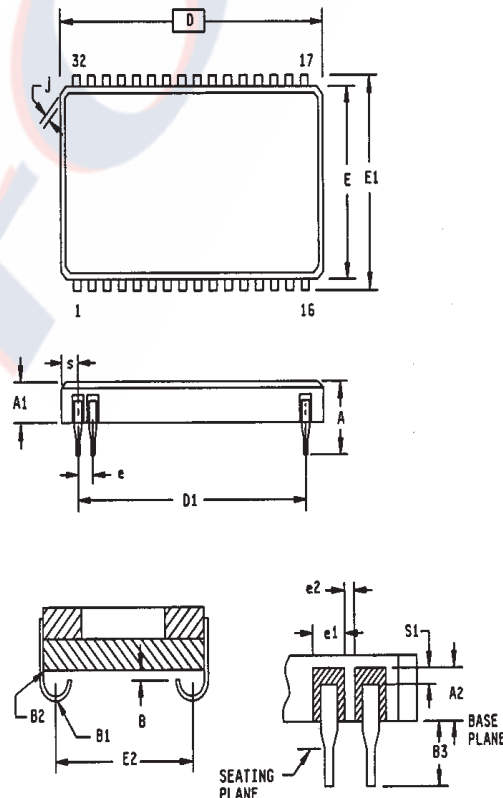



Ashley Crt, Henley,
Marlborough, Wilts, SN8 3RH UK
Tel: +44(0)1264 731200
Fax: +44(0)1264 731444
E-mail

sales@forcetechnologies.co.uk

www.forcetechnologies.co.uk

Unless otherwise stated in this SCD/Data sheet, Force Technologies Ltd reserve the right to make changes, without notice, in the products, including circuits, cells and/or software, described or contained herein in order to improve design and/or performance. Force Technologies resumes no responsibility or liability for the use of any of these products, conveys no licence or any title under patent, copyright, or mask work to these products, and makes no representation or warranties that that these products are free from patent, copyright or mask work infringement, unless otherwise specified.

Life Support Applications

Force Technologies products are not designed for use in life support appliances, devices or systems where malfunction of a Force Technologies product can reasonably be expected to result in a personal injury. Force Technologies customers using or selling Force Technologies products for use in such applications do so at their own risk and agree to fully indemnify Force Technologies for any damages resulting from such improper use or sale.

All trademarks acknowledged

Copyright Force Technologies Ltd 2008

