



Doc. Version	0.1
Total Page	18
Date	2008/11/27

Product Specification

4.3" COLOR TFT-LCD MODULE

MODEL NAME: A043FW02 V3

< > Preliminary Specification

< > Final Specification

Note: The content of this specification is subject to change.

© 2008 AU Optronics
All Rights Reserved,
Do Not Copy.



Record of Revision

Version	Revise Date	Page	Content
0.0	2008/09/01		First draft.
0.1	2008/11/27	9	Update Electrical Characteristics
		11	Update Power on/off sequence
		12	Update Timing Condition

Contents:

<u>A. General Description</u>	4
<u>B. Features</u>	4
<u>C. Physical Specifications</u>	5
<u>D. Outline Dimension (Tentative)</u>	6
<u>E. Electrical Specifications</u>	7
1. Pin Assignment	7
2. Absolute Maximum Ratings.....	9
3. Electrical Characteristics	9
TFT- LCD Pane	9
4. Suggested Application Circuit	10
a. Power on/off sequence	11
b. Timing Condition	12
c. Timing Diagram	13
<u>F. Optical specifications (Note 1, 2)</u>	15
<u>G. Reliability Test Items</u>	17
<u>H. Packing Form</u>	18

A. General Description

A043FW02 V3 is an amorphous transmissive type Thin Film Transistor Liquid crystal Display (TFT-LCD). This model is composed of a TFT-LCD, a driver and FPC .

B. Features

- WQVGA resolution in RGB stripe dot arrangement
- DC/DC integrated
- Interfaces: parallel RGB 24-bit
- Wide viewing angle
- Green design

C. Physical Specifications

NO.	Item	Unit	Specification	Remark
1	Display Resolution	dot	480 RGB (H)×272(V)	
2	Active Area	mm	95.04(H)×53.856(V)	
3	Screen Size	inch	4.3(Diagonal)	
4	Dot Pitch	mm	0.066(H)×0.198(V)	
5	Color Configuration	--	R. G. B. Stripe	Note 1
6	Color Depth	--	16.7M Colors	
7	Overall Dimension	mm	102.5(H) × 63.3(V) × 1.435(T)	Note 2
8	Weight	g	18	
9	Display Mode	--	Normally White	
10	Gray Level Inversion Direction		6 O'clock	

Note 1: Below figure shows dot stripe arrangement.

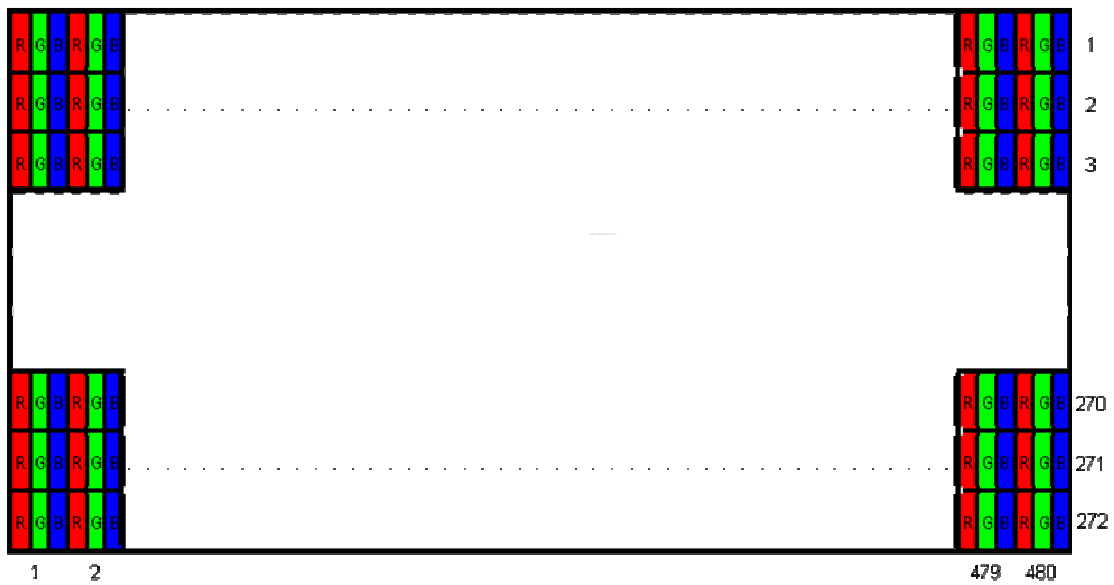

Note 2: Not including FPC. Refer to the drawing next page for further information.

D. Outline Dimension (Tentative)

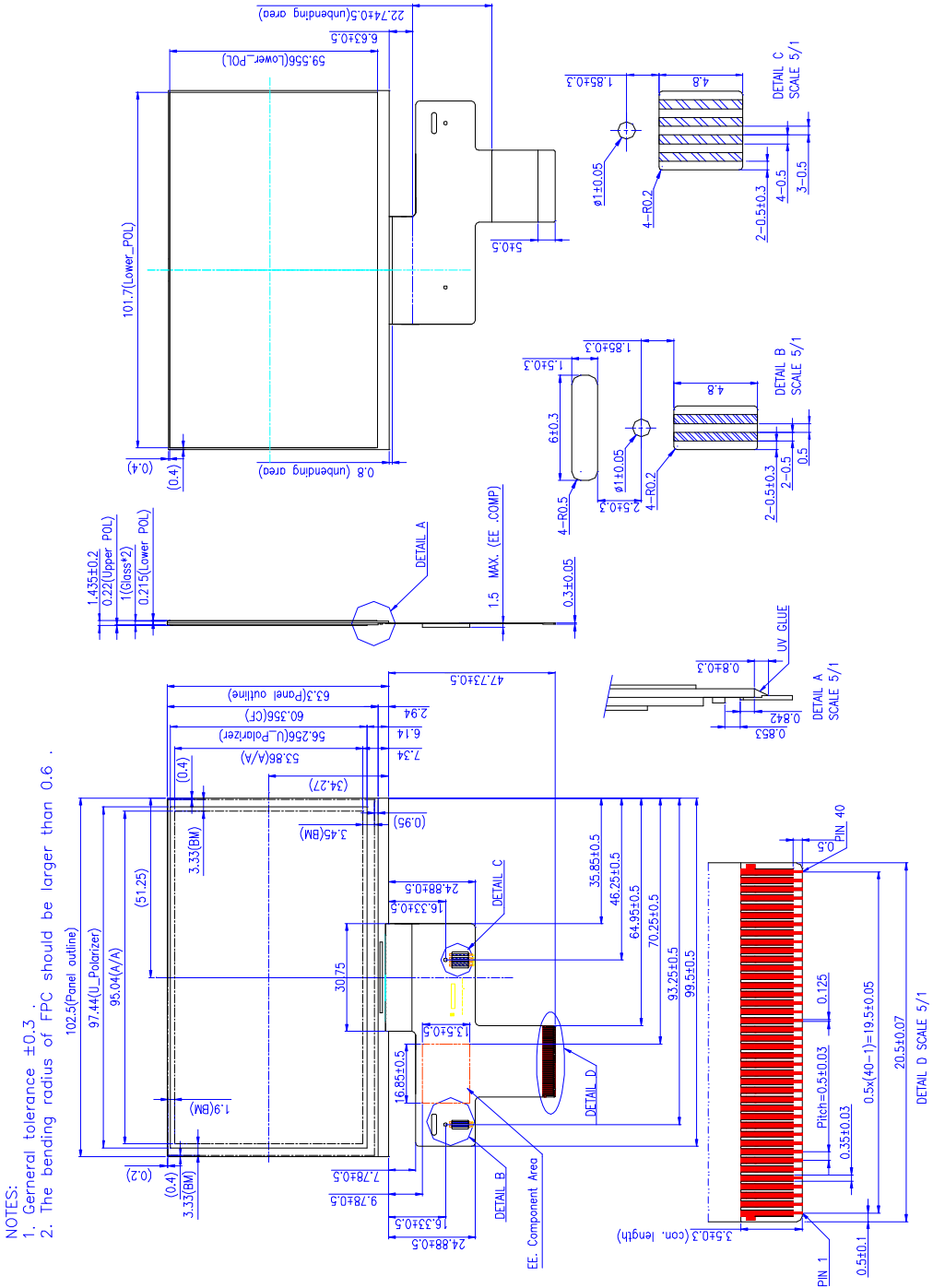

E. Electrical Specifications

1. Pin Assignment

No.	Pin Name	I/O	Description	Remarks
1	VLED-	PI	LED backlight cathode	
2	VLED+	PI	LED backlight anode	
3	GND	G	Ground	
4	VDD	P	Power Supply	
5	R0	I	Red Data (LSB)	
6	R1	I	Red Data	
7	R2	I	Red Data	
8	R3	I	Red Data	
9	R4	I	Red Data	
10	R5	I	Red Data	
11	R6	I	Red Data	
12	R7	I	Red Data (MSB)	
13	G0	I	Green Data (LSB)	
14	G1	I	Green Data	
15	G2	I	Green Data	
16	G3	I	Green Data	
17	G4	I	Green Data	
18	G5	I	Green Data	
19	G6	I	Green Data	
20	G7	I	Green Data (MSB)	
21	B0	I	Blue Data (LSB)	
22	B1	I	Blue Data	
23	B2	I	Blue Data	
24	B3	I	Blue Data	
25	B4	I	Blue Data	
26	B5	I	Blue Data	
27	B6	I	Blue Data	
28	B7	I	Blue Data (MSB)	
29	GND	G	Ground	
30	DCLK	I	Pixel Clock	
31	DISP	I	Display On/Off Signal	
32	HSYNC	I	Horizontal Synchronizing Signal	
33	VSYNC	I	Vertical Synchronizing Signal	

34	DE	I	Data Enable	
35	NC		Not Connected	
36	GND	G	Ground	
37	NC	-	Reserved for Touch Panel	
38	NC	-	Reserved for Touch Panel	
39	NC	-	Reserved for Touch Panel	
40	NC	-	Reserved for Touch Panel	

I: Digital signal input, O: Digital signal output, G: GND, PI: Power input, C: Capacitor

2. Absolute Maximum Ratings

Items	Symbol	Values		Unit	Condition
		Min.	Max.		
Power Supply Voltage	V _{DD}	-0.3	4.5	V	
Operation Temperature	T _{op}	-20	70	°C	
Storage Temperature	T _{st}	-30	80	°C	

Note 1. If the operating condition exceeds the absolute maximum ratings, the TFT-LCD module may be damaged permanently. Also, if the module operated with the absolute maximum ratings for a long time, its reliability may drop.

3. Electrical Characteristics

The following items are measured under stable condition and suggested application circuit.

TFT- LCD Pane

Parameter	Symbol	Min	Typ	Max	Unit	Notes
Power Supply Voltage	V _{DD}	3	3.3	3.6	V	PWR_SEL=H
	V _{DD}	2.25	2.5	3	V	PWR_SEL=L
Input Signal Voltage	V _{ih}	0.8* VDD	--	VDD	V	
	V _{il}	GND	--	0.2* VDD	V	
Frame Frequency	f _{Frame}	--	60	70	Hz	
Dot Data Clock	DCLK	5	9.2	12	MHz	

Note 1. Panel surface temperature should be kept less than content of section E.2. "Absolute maximum ratings"

4. Suggested Application Circuit

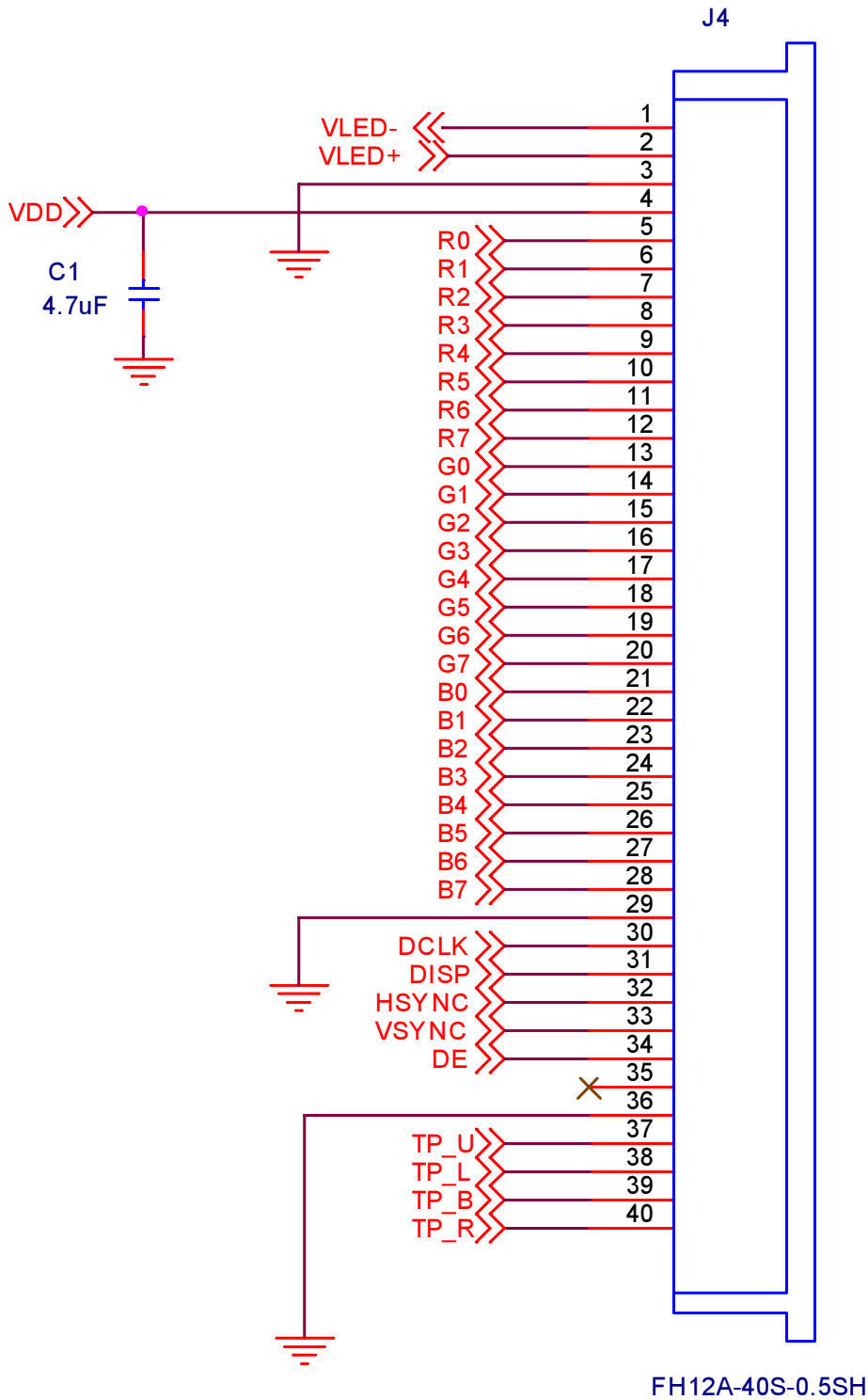

5. AC Timing

a. Power on/off sequence

Power On (Display ON; Standby Disabling)

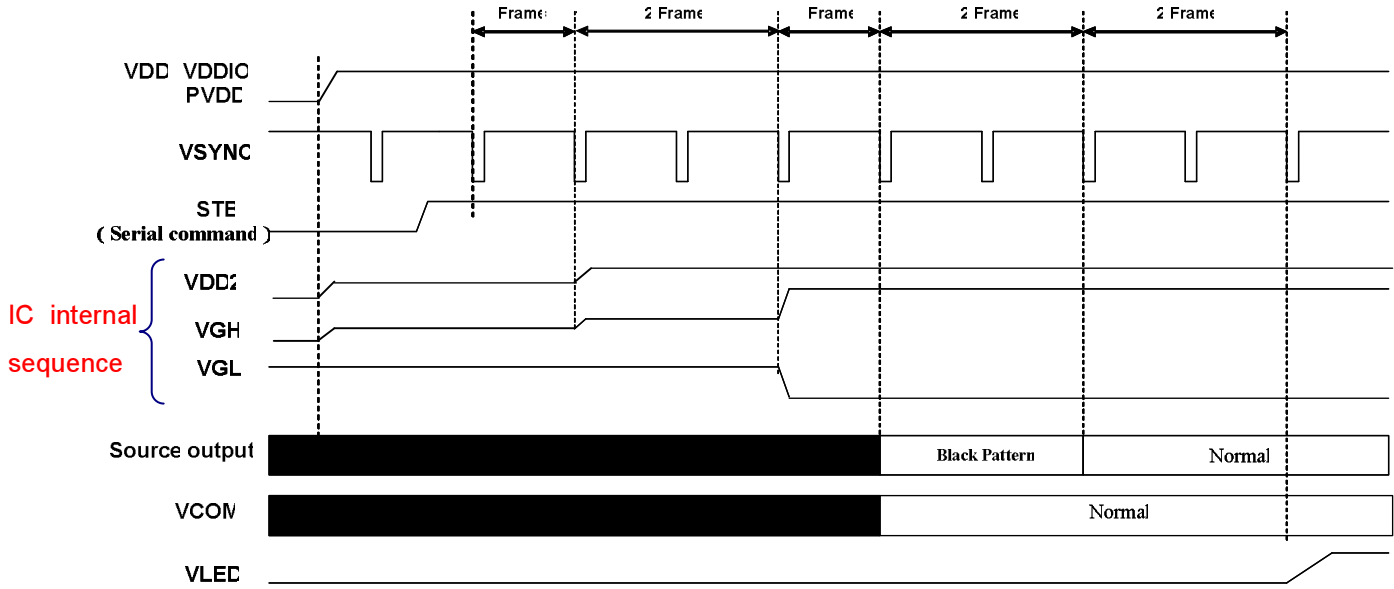

Notes: The driver IC default is on standby mode. It can be changed to normal operation by using DISP hard pin.

Power-Off (Display Off; Standby Enabling)

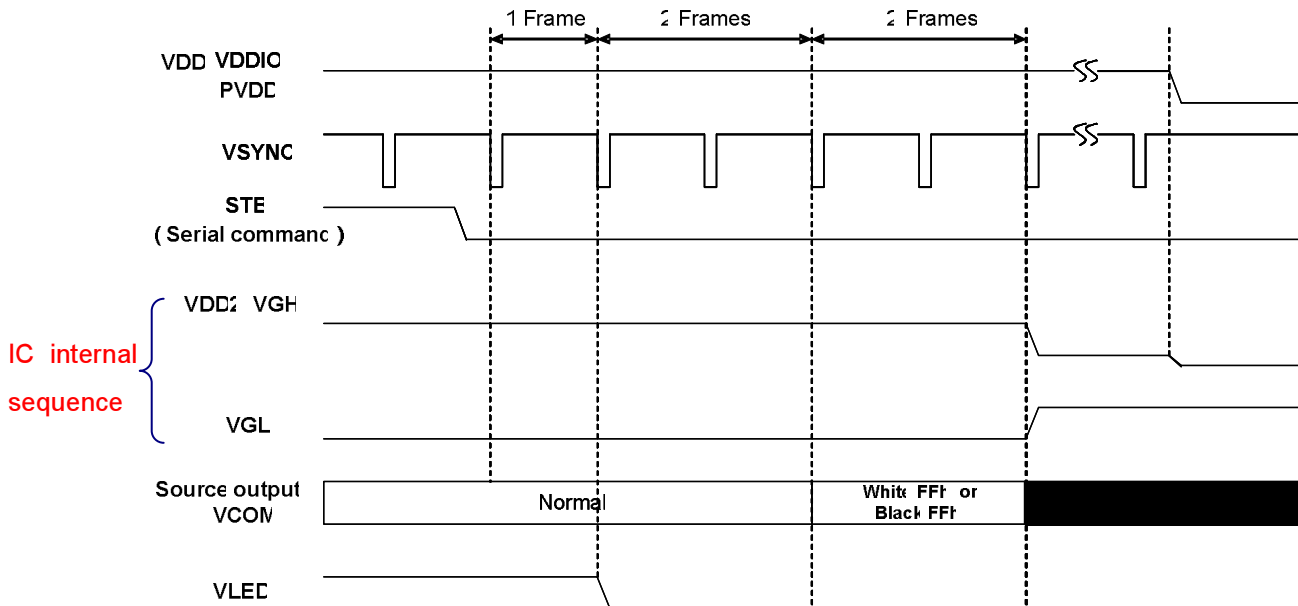

b. Timing Condition

Parameter		Symbol	Min.	Typ.	Max.	Unit.	Remark
DCLK	Frequency	1/Tdclk	5	9.2	12	MHz	
	CLK pulse duty	Tcwh	40	--	--	ns	
	CLK pulse duty	Tcwl	40	--	--	ns	
Data	Setup Time	Tdsu	12	--	--	ns	
	Hold Time	Tdhd	12	--	--	ns	
DE	Setup Time	Tdesu	12	--	--	ns	
	Hold Time	Tdehd	12	--	--	ns	
Frame Frequency	Cycle	tv		16.7		ms	
1 Frame Scanning Time	Cycle	tv	275	288	335	H	
	Display Period	tvdisp	272			H	
	Front porch	Tvfp	1	4	--	H	
	Pulse width	Tvw	1	10	--	H	
	Back porch	Tvbp	2	12	--	H	
1 Line Scanning Time	Cycle	Th	490	531	605	DCLK	
	Display Period	Thdisp	480			DCLK	
	Front porch	Thfp	2	8	--	DCLK	
	Pulse width	Thw	1	1	--	DCLK	
	Back porch	thbp	8	43	--	DCLK	

Note 1: Sync mode just can be used on the typical timing setting.

c. Timing Diagram

Vertical Timing of Input (Sync-DE mode)

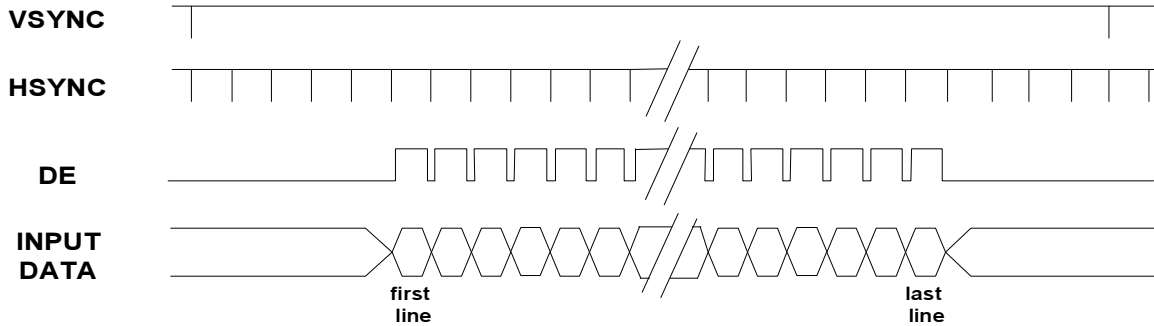

Vertical Timing of Input (Sync mode)

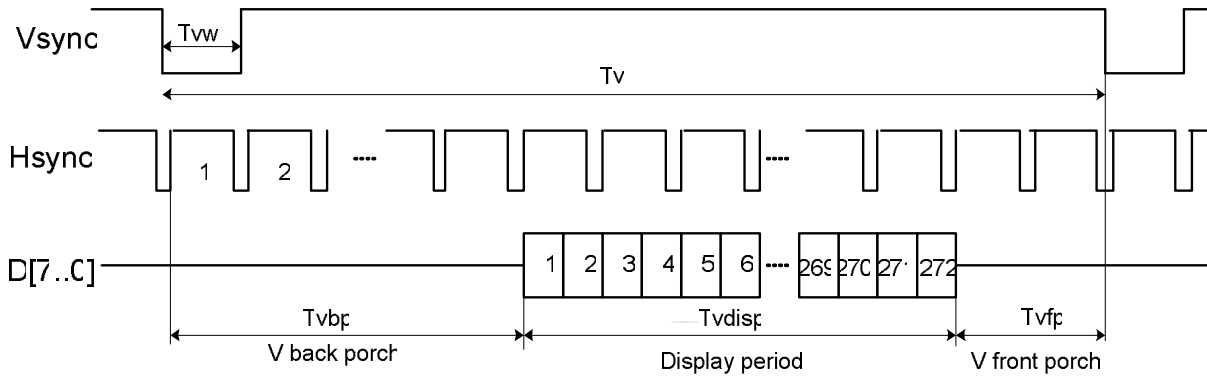

Horizontal Timing of Input (Sync mode)

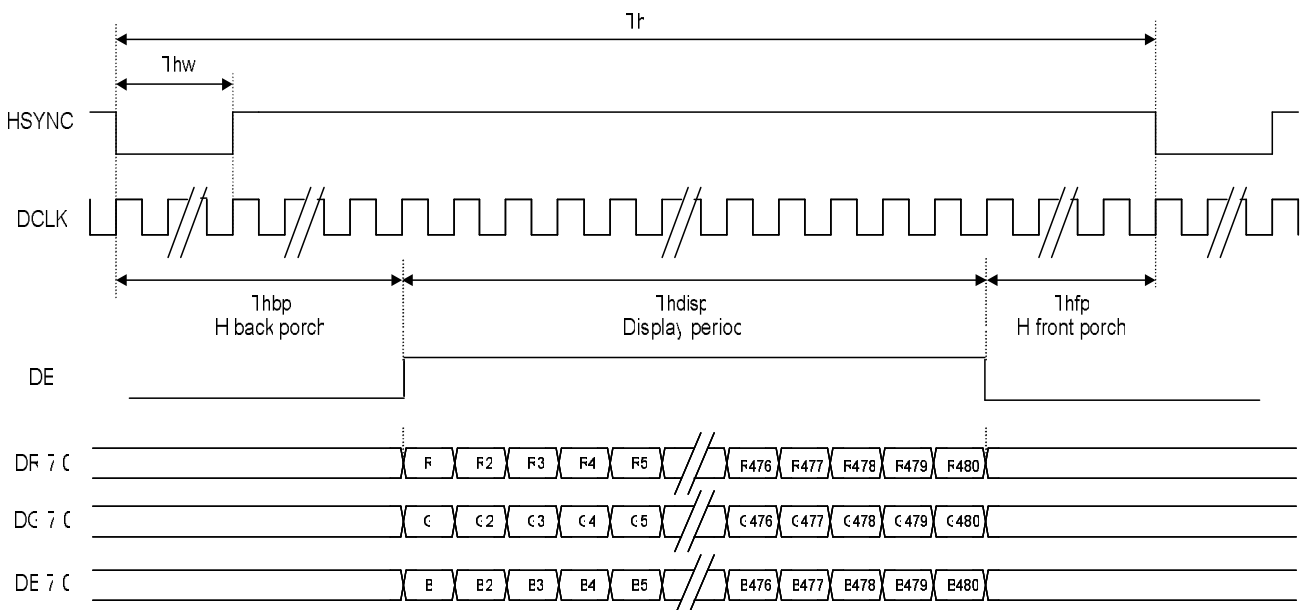

Horizontal Timing of Input (Sync-DE mode)

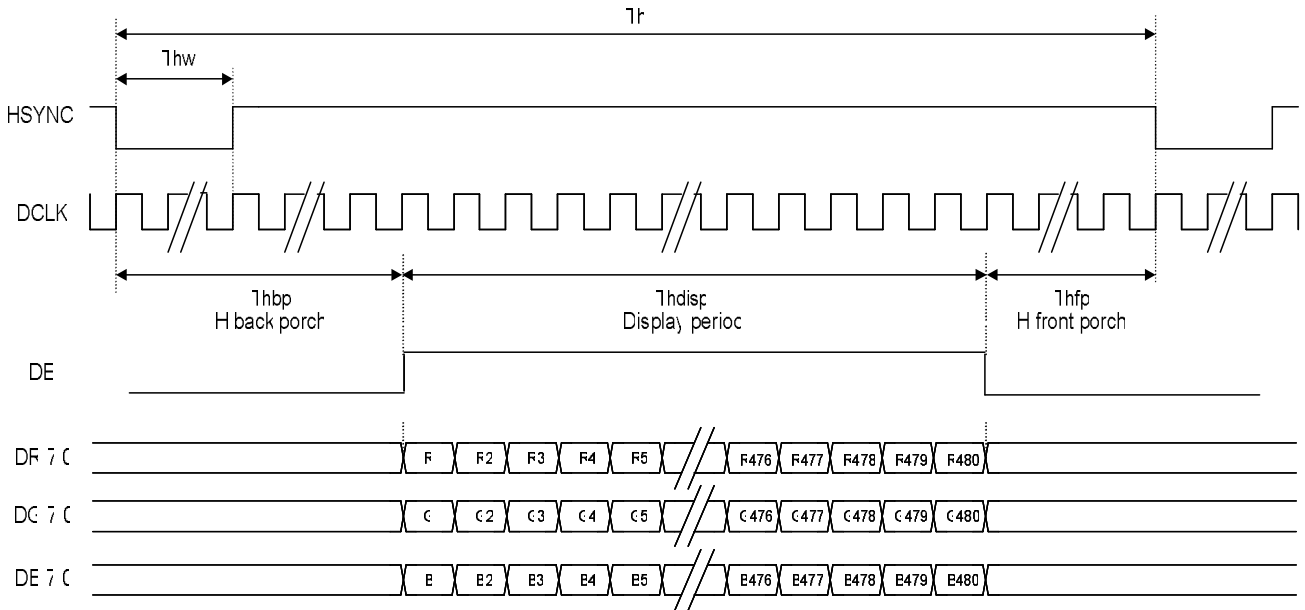

Clock and data input timing diagram

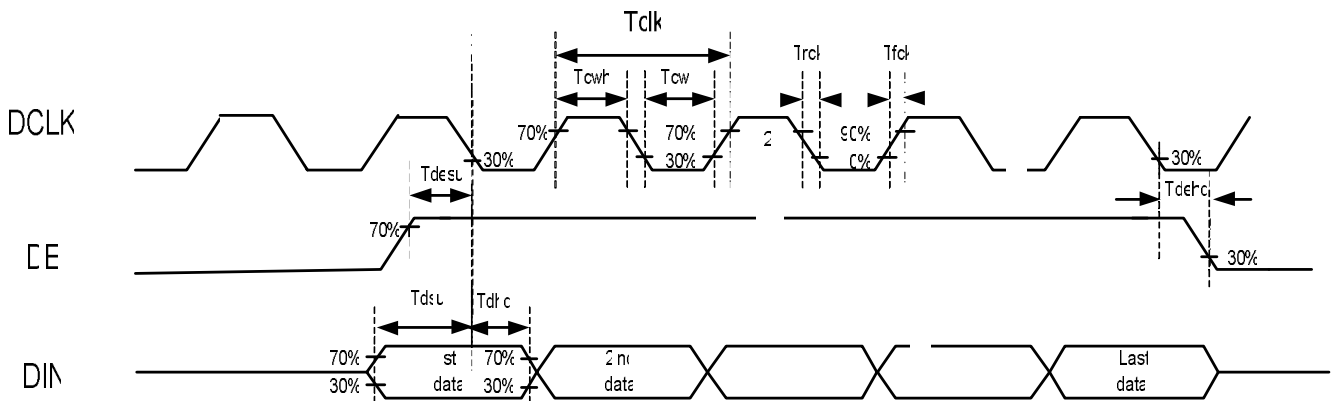

F. Optical specifications (Note 1, 2)

Item	Symbol	Condition	Min.	Typ.	Max.	Unit	Remark
Response Time							
Rise	Tr	$\theta = 0^\circ$	-	15		ms	Note 3
Fall	Tf		-	20		ms	
Contrast ratio	CR	At optimized viewing angle	200	300	-		Note 5, 6
Viewing Angle							
Top		CR ≥ 10		50	-	deg.	Note 7, 8
Bottom			60	-			
Left			70	-			
Right			70	-			
White Chromaticity	X	$\theta = 0^\circ$	0.27	0.32	0.37		
	y	$\theta = 0^\circ$	0.29	0.34	0.39		

Note 1: Measurement should be performed in the dark room, optical ambient temperature =25°C, and backlight current $I_L=20$ mA

Note 2: To be measured on the center area of panel with a field angle of 1° by Topcon luminance meter BM-7, after 10 minutes operation.

Note 3: Definition of response time:

The output signals of photo detector are measured when the input signals are changed from “black” to “white”(falling time) and from “white” to “black”(rising time), respectively.

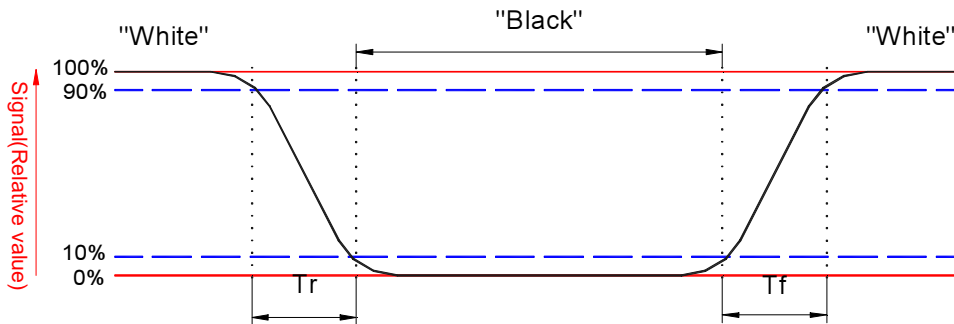

Note 4. From liquid crystal characteristics, response time will become slower and the color of panel will become darker when ambient temperature is below 25°C.

Note 5. Contrast ratio is calculated with the following formula.

$$\text{Contrast ratio} = \frac{\text{Photo detector output when LCD is at "White" state}}{\text{Photo detector output when LCD is at "Black" state}}$$

Note 6. Definition of viewing angle: refer to figure as below.

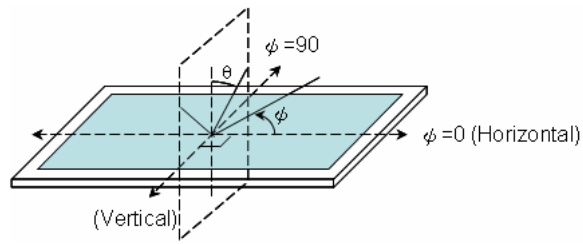

Note 7. The viewing angles are measured at the center area of the panel when all the input terminals of LCD panel are electrically opened.

Note 8. Brightness is measured at the center of the display perpendicular to the panel surface.

G. Reliability Test Items

No.	Test items	Conditions		Remark
1	High Temperature Storage	Ta= 80°C	240Hrs	
2	Low Temperature Storage	Ta= -30°C	240Hrs	
3	High Temperature Operation	Ta= 70°C	240Hrs	
4	Low Temperature Operation	Ta= -20°C	240Hrs	
5	High Temperature & High Humidity	Ta= 60°C. 90% RH	240Hrs	Operation
6	Heat Shock	-25°C ~70°C, 50 cycle, 2Hrs/cycle		Non-operation
7	Vibration (With Carton)	Random vibration: 0.015G ² /Hz from 5~200Hz -6dB/Octave from 200~500Hz		IEC 68-34
8	Drop (With Carton)	Height: 60cm 1 corner, 3 edges, 6 surfaces		

Note 1: Ta: Ambient temperature.

Note 2: In the standard condition, there is not display function NG issue occurred. All the cosmetic specification is judged before the reliability stress.

H. Packing Form

