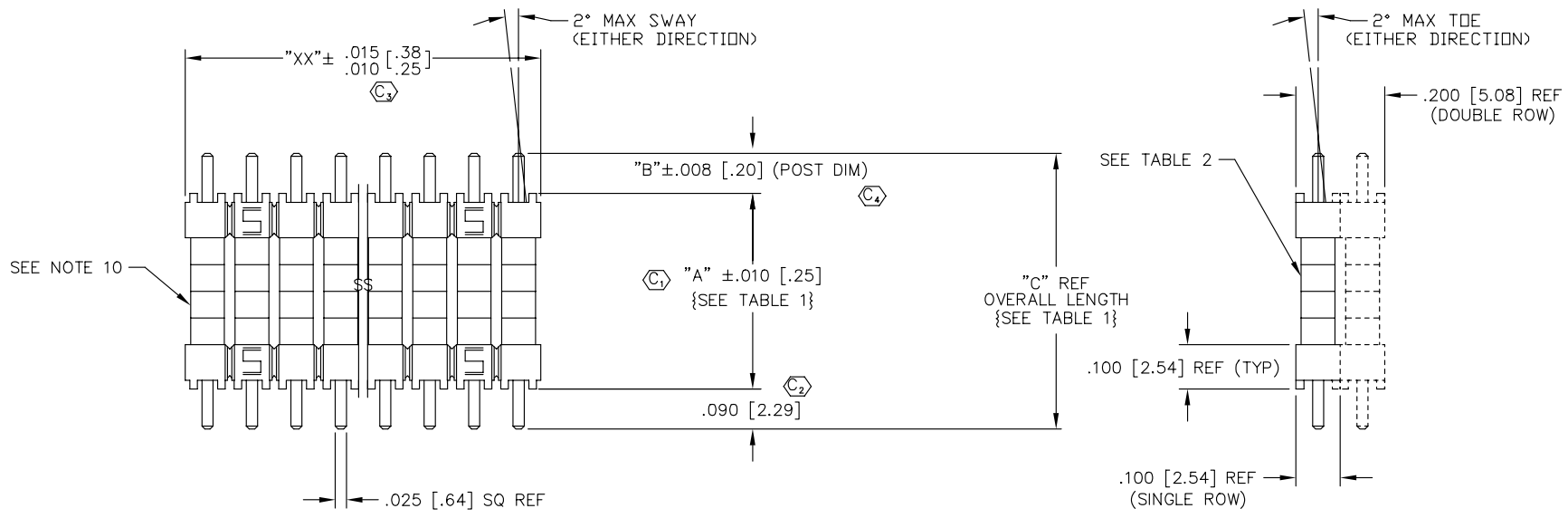
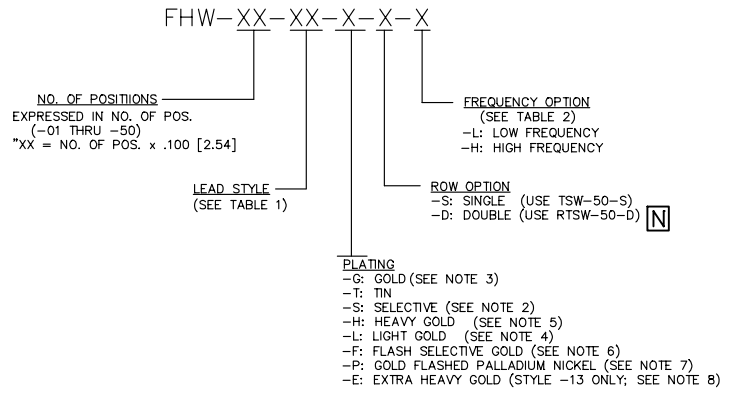

TABLE 1

LEAD STYLE	NO. OF FERRITES	TERMINAL	"C"	"A"	"B" POST DIM BASED ON A TAIL OF .090.	IMPEDANCE Ω			
						FREQ	10MHz	25MHz	100MHz
07	1	T-1S6-07-X-2	.430 [10.92]	.260 [6.60]	.080 [2.03]	LOW HIGH	6MIN ---	12±20% 7MIN	--- 22±20%
08	2	T-1S6-08-X-2	.530 [13.46]	.320 [8.13]	.120 [3.05]	LOW HIGH	12MIN ---	24±20% 14MIN	--- 44±20%
09	6	T-1S6-09-X-2	.730 [18.54]	.560 [14.22]	.080 [2.03]	LOW HIGH	36MIN ---	72±20% 42MIN	--- 132±20%
10	7	T-1S6-10-X-2	.830 [21.08]	.620 [15.75]	.120 [3.05]	LOW HIGH	42MIN ---	84±20% 49MIN	--- 154±20%
15	2	T-1S6-15-X-2	.630 [16.00]	.320 [8.13]	.220 [5.59]	LOW HIGH	12MIN ---	24±20% 14MIN	--- 44±20%
17	1	T-1S6-17-X-2	.480 [12.19]	.260 [6.60]	.130 [3.30]	LOW HIGH	6MIN ---	12±20% 7MIN	--- 22±20%



- NOTES:
- HEIGHT VARIATION BETWEEN ANY TWO PINS SHALL BE .010 [.25] MAX.
 - S PLATING: PLATED AREA WILL BE ON THE LONGER TAIL.
 - G PLATING: HEAVY GOLD ON LONGER TAIL
 - L PLATING: GOLD ON LONGER TAIL
 - H PLATING: HEAVY GOLD ON LONGER TAIL
 - F PLATING: FLASH SELECTIVE GOLD ON LONGER TAIL
 - P PLATING: GOLD FLASHED PALLADIUM NICKEL ON LONGER TAIL
 - Ⓢ REPRESENTS A CRITICAL DIMENSION.
 - No. OF STACKED FERRITES DEPENDS ON LEAD STYLE AND BOARD SPACE.
 - PACKAGING: LAYER PACKAGING.
 - TSW-50-D MAY BE USED IF RTSW-50-D IS UNAVAILABLE.

TABLE 2

FREQUENCY	SAMTEC PART NO.
-L	FH-060-L
-H	FH-060-H

PROPRIETARY NOTE
THIS DOCUMENT CONTAINS INFORMATION CONFIDENTIAL AND PROPRIETARY TO SAMTEC INC. AND SHALL NOT BE REPRODUCED OR TRANSFERRED TO OTHER DOCUMENTS OR DISCLOSED TO OTHERS OR USED FOR ANY PURPOSE OTHER THAN THAT FOR WHICH IT WAS OBTAINED WITHOUT THE EXPRESSED WRITTEN CONSENT OF SAMTEC INC.

EXISPROD\ASSEMBLY\FERRITE FHW-ASM

samtec

520 PARK EAST BLVD. NEW ALBANY, INDIANA 47150
PHONE (812) 944-6733 P.O. BOX 1147
CODE 55322

MADE BY: PLUMMER 01/08/96

FHW-XX-XX-X-X-X
SHEET 1 OF 1