

TITLE: SPECIFICATION CONTROL DRAWING

PART IDENTIFIER: HRMXXXXXXXXS

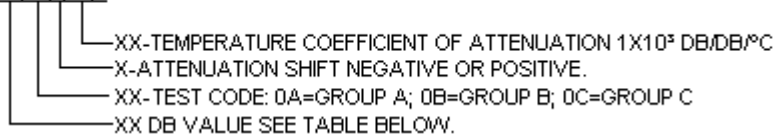

SHIFT (NEG)	DB VALUE	FREQUENCY RANGE
-003	1, 2, 3, 4, 5, 6, 8	DC - 18 GHZ
-004	1, 2, 3, 4, 6	
-005	1, 2, 3, 4, 5, 6	
-006	2, 3, 4	DC - 12.4 GHZ
-007	2, 3, 4, 5, 6	
-009	6	

DESCRIPTION: TEMPERATURE VARIABLE CHIP ATTENUATOR WITH HIGH RELIABILITY TESTING.

NOTE: SINGLE LOT AND DATE CODE AVAILABLE UPON REQUEST.

ASSEMBLY DWG: N/A

1.0 SPECIFICATIONS:

- 1.1 ELECTRICAL:
 - 1.1.1 IMPEDANCE: 50 OHMS NOMINAL.
 - 1.1.2 OPERATING FREQUENCY RANGE: DC - 12.4GHZ.
 - 1.1.3 ATTENUATION VALUES AVAILABLE: SEE TABLE ABOVE.
 - 1.1.4 ATTENUATION ACCURACY AT 25°C: ±0.5DB @ 1 GHZ.
 - 1.1.5 VSWR: 1.30:1 MAX. @ 1GHZ.
 - 1.1.6 INPUT POWER: 200 MILLIWATTS CW.
 - 1.1.6.1 FULL RATED POWER TO 125°C, DERATED LINEARLY TO 0 WATTS AT 150°C.
 - 1.1.7 TEMPERATURE COEFFICIENT OVER OPERATING TEMPERATURE RANGE: SEE TABLE ABOVE, TEMPERATURE COEFFICIENT TOLERANCE: ±0.001 DB/DB/°C.
- 1.2 MECHANICAL:
 - 1.2.1 OUTLINE DWG: SEE SHEET 3.
 - 1.2.2 WORKMANSHIP: PER MIL-PRF-55342.
- 1.3 ENVIRONMENTAL:
 - 1.3.1 OPERATING TEMPERATURE RANGE: -55°C TO +150°C
- 1.4 ELECTROSTATIC DISCHARGE CONTROL: PER MIL-STD-1686.

2.0 UNIT MARKING: DB VALUE (X), DIRECTION OF SHIFT (N) AND TCA SHIFT (X).
LEGIBILITY AND PERMANENCY PER MIL-STD-130.

3.0 QUALITY ASSURANCE:

- 3.1 VERIFY 100% VISUAL PRE-CAP INSPECTION PERFORMED PER TP-8965.
- 3.2 PERFORM GROUP A, B AND/OR C TESTING AS INDICATED BY THE PART NUMBER PER TP-8965.
 - 3.2.1 GROUP A TESTING
 - 3.2.1.1 VISUAL AND MECHANICAL INSPECTION PER SHEET 3.
 - 3.2.1.2 INITIAL RF MEASUREMENTS – MEASURE AND RECORD VSWR @ 1 GHZ AND ATTENUATION AT DC (0 GHZ) AND 1.0 GHZ.
 - 3.2.1.3 THERMAL SHOCK – 10 CYCLES FROM -55°C TO +125°C.
 - 3.2.1.4 AFTER THERMAL SHOCK RF MEASUREMENTS - MEASURE AND RECORD VSWR @ 1 GHZ AND ATTENUATION AT DC (0 GHZ) AND 1.0 GHZ.
 - 3.2.1.5 BURN-IN – DURATION OF 168 HRS AT INPUT POWER SEE 1.1.6.
 - 3.2.1.6 SUB-GROUP 1 (3 SAMPLES)
 - 3.2.1.6.1 TCA MEASUREMENT - MEASURE AND RECORD ATTENUATION AT DC EVERY 20°C FROM -55°C TO +125°C PER 2.5.1 OF TP-8965.
 - 3.2.1.6.2 CALCULATE, USING LINEAR REGRESSION, THE SLOPE OF THE CURVE.

ENG		PUR		MFG		PLAN		SM	
CC				QA					
EMC TECHNOLOGY		CAGE CODE # 24602				DWG #	1009795000		
8851 SW OLD KANSAS AVE.		CHANGE NOTICE	EN 04-E033			REV LVL	-		
STUART, FL 34997						SHEET	1 OF 3		

CALCULATE TCA USING THE FOLLOWING FORMULA:

$$TCA = \frac{SLOPE}{ATTENUATION @ 25^{\circ}C}$$

3.3.1.6.3 ACCEPTANCE LIMITS: NOMINAL TCA +/-0.001 dB/dB/°C.

3.2.2 GROUP B TESTING (7 SAMPLES APPROVED FROM GROUP A).

3.2.2.1 SUB-GROUP 1 (3 SAMPLES)

3.2.2.1.1 LOW TEMPERATURE OPERATION

3.2.2.1.1.1 USE FINAL ELECTRICAL MEASUREMENTS FROM GROUP A.

3.2.2.1.1.2 DISSIPATE LOW POWER FOR A DURATION OF 45 +/-0 MINUTES. ALLOW TO STABILIZE AT 25°C FOR 24 HOURS.

3.2.2.1.2 AFTER LOW TEMPERATURE ELECTRICAL MEASUREMENTS - MEASURE AND RECORD VSWR @ 1 GHZ AND ATTENUATION AT DC (0 GHZ) AND 1.0 GHZ.

3.2.2.1.3 HIGH TEMPERATURE BAKE – +125°C +/- 5°C FOR 100 HRS THEN STABILIZE AT 25°C FOR 4 HRS.

3.2.2.1.3.1 VISUAL EXAMINATION - INSPECT FOR EVIDENCE OF MECHANICAL DAMAGE.

3.2.2.1.4 AFTER HIGH TEMPERATURE BAKE ELECTRICAL TEST - MEASURE AND RECORD VSWR @ 1 GHZ AND ATTENUATION AT DC (0 GHZ) AND 1.0 GHZ.

3.2.2.1.5 TERMINATION ADHESION - SOLDER A WIRE AND PULL WITH 15 GRAMS PERPENDICULAR TO AND AWAY FROM THE SURFACE AREA.

3.2.2.1.5.1 VISUAL INSPECTION – THERE SHALL BE NO SEPARATION OF MATERIAL.

3.2.2.1.6 TERMINATION SOLDERABILITY IMMERSE EACH SAMPLE 5 SECONDS IN A SOLDER POT HELD AT 220°C +/- 5°C USING 60/40 OR 63/37 TIN-LEAD COMPOSITION.

3.2.2.2 SUB-GROUP 2 (4 SAMPLES)

3.2.2.2.1 INITIAL RF MEASUREMENTS - USE FINAL ELECTRICAL MEASUREMENTS FROM GROUP A.

3.2.2.2.2 LIFE TEST – OPERATE SAMPLES UNITS FOR 1000 HRS AT 70°C AT INPUT POWER PER 1.1.6. ELECTRICAL MEASUREMENTS SHALL BE MADE AT 250 +/-48/-0 HRS, 500 +/-48/-0 HRS, AND 1000 +/-48/-0 HRS.

3.2.2.2.3 FINAL RF MEASUREMENTS - MEASURE AND RECORD VSWR @ 1 GHZ AND ATTENUATION AT DC (0 GHZ) AND 1.0 GHZ.

3.2.3 GROUP C (QCI TESTING 4 SAMPLES APPROVED FROM GROUP A).

3.2.3.1 LOAD LIFE TEST – BURN-IN UNITS AT 70°C WITH INPUT POWER (SEE 1.1.6) FOR A DURATION OF 1000 HOURS (1½ HOURS ON, ½ HOUR OFF). MEASURE AND RECORD ELECTRICALS AT 0, 250, 500, AND 1000 HOURS.

3.2.3.2 AFTER LOAD LIFE RF MEASUREMENTS – MEASURE AND RECORD VSWR AND ATTENUATION AT 1 GHZ AT 25°C. TEST ACCEPTABLE LIMITS PER 4.2.1 OF TP-8965.

3.4 TEST DATA REQUIREMENTS:

3.4.1 TEST DATA REQUIRED FOR CUSTOMER - SEE PARAGRAPH 5.0 OF TP-8965.

3.4.2 DATA RETENTION - 24 MONTHS.

3.4.3 TEST SAMPLES REQUIRED FOR CUSTOMER - SEE PARAGRAPH 5.0 OF TP-8965.

4.0 PACKAGING: STANDARD PACK PER MC0023. (SERIALIZED WAFFLE PACK)

EMC TECHNOLOGY 8851 SW OLD KANSAS AVE. STUART, FL 34997	CAGE CODE # 24602		DWG #	1009795000
	CHANGE NOTICE	EN 04-E033	REV LVL	-
			SHEET	2 OF 3

PART ID REF
HRMXXXXXXXXS

U.S. PATENT NO. 5332981

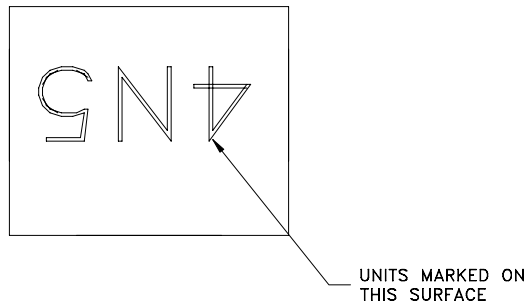
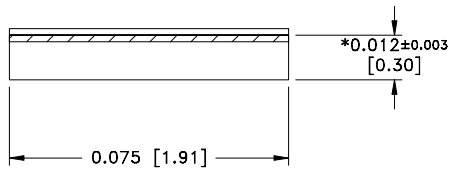
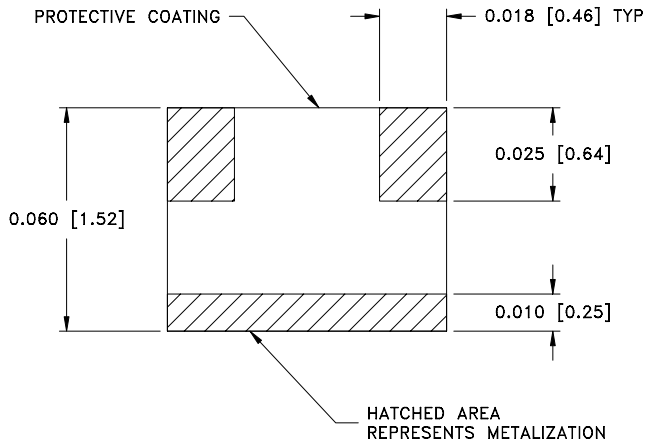

MECHANICAL SPECIFICATIONS:

SUBSTRATE:
MATERIAL - ALUMINA 96%, MIL-I-10.
TERMINAL:
MATERIAL - THICK FILM, NICKEL BARRIER,
SOLDER COATED.
RESISTIVE ELEMENT:
MATERIAL - THICK FILM.

METRIC EQUIVALENTS GIVEN IN [mm]
FOR REFERENCE INFORMATION ONLY

* DIMENSIONS APPLY BEFORE SOLDER. ALLOW
0.015 MAX FOR ALL PRETINNED SURFACES.



POWER RATING AND DERATING

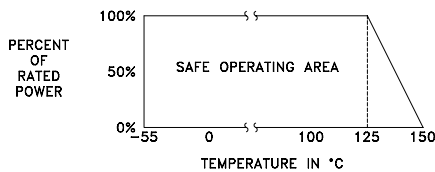

EMC Technology
8851 SW OLD KANSAS AVE
STUART, FL 34997
PHONE NO. (772)286-9300
FAX NO. (772)283-5286

UNLESS OTHERWISE SPECIFIED DIMENSIONS ARE IN INCHES
TOLERANCES
FRACT --- --
ANG --- --
XX --- --
XXX ±0.005
XXXX --- --

THESE DRAWINGS AND SPECIFICATIONS ARE THE PROPERTY OF EMC TECHNOLOGY INC AND SHALL NOT BE DUPLICATED OR USED AS BASIS FOR THE MANUFACTURE OR SALE OF PARTS OR DEVICES WITHOUT PERMISSION.

CAGE CODE 24602	SCALE 32:1	DRAWN BY JG	CHECKED BY	APPROVED BY
REV -	CHANGE NOTICE EN 03-268	DRAWING NO 1009795000	SHEET 3 OF 3	