

Document Title

512K x16 bit 1.8V Super Low Power Full CMOS slow SRAM

Revision History

<u>Revision No</u>	<u>History</u>	<u>Draft Date</u>	<u>Remark</u>
00	Initial Release	May.29.2001	Preliminary
01	DC Electrical Characteristics - ICC changed 4mA -> 3mA - ICC1 changed 25mA at 70ns -> 15mA at 70ns - ICC1 changed 3mA at 1us -> 2mA at 1us - ISB (TTL) changed 50uA -> 300uA AC Test Loads - (R1//R2) 40910hm // 32730hm -> 30700hm // 31500hm AC Test Conditions - Output Load changed 5pF -> 30pF - Input Pulse Level 0.4V to 1.6V -> 0.2V to Vcc-0.2 Data Retention Electric Characteristic - ICCDR LL-Part changed 20uA -> 10uA	Oct.22.2002	Final

DESCRIPTION

The HY62SF16804B is a high speed, super low power and 8Mbit full CMOS SRAM organized as 512K words by 16bits. The HY62SF16804B uses high performance full CMOS process technology and is designed for high speed and low power circuit technology. It is particularly well-suited for the high density low power system application. This device has a data retention mode that guarantees data to remain valid at a minimum power supply voltage of 1.2V.

- Fully static operation and Tri-state output
- TTL compatible inputs and outputs
- Battery backup(LL/SL-part)
 - 1.2V(min) data retention
- Standard pin configuration
 - 48-fBGA

FEATURES

Product No.	Voltage (V)	Speed (ns)	Operation Current/I _{cc} (mA)	Standby Current(μA)		Temperature (°C)
				LL	SL	
HY62SF16804B-C	1.65~2.3	70/85/100	3	15	8	0~70
HY62SF16804B-I	1.65~2.3	70/85/100	3	15	8	-40~85

Note 1. C : Commercial, I : Industrial
 2. Current value is max.

PIN CONNECTION (Top View)

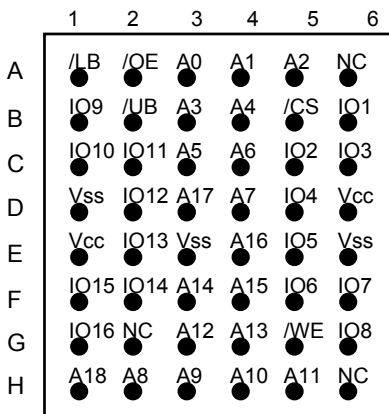

BLOCK DIAGRAM

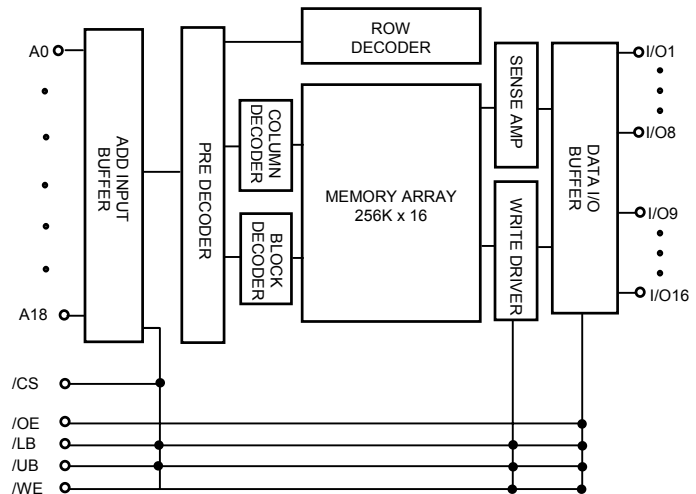

PIN DESCRIPTION

Pin Name	Pin Function	Pin Name	Pin Function
/CS	Chip Select	I/O1~I/O16	Data Inputs / Outputs
/WE	Write Enable	A0~A18	Address Inputs
/OE	Output Enable	Vcc	Power(1.65V~2.3V)
/LB	Lower Byte Control(I/O1~I/O8)	Vss	Ground
/UB	Upper Byte Control(I/O9~I/O16)	NC	No Connection

ORDERING INFORMATION

Part No.	Speed	Power	Package	Temp.
HY62SF16804B-DFC	70/85/100	LL-part	fBGA	C
HY62SF16804B-SFC	70/85/100	SL-part	fBGA	C
HY62SF16804B-DFI	70/85/100	LL-part	fBGA	I
HY62SF16804B-SFI	70/85/100	SL-part	fBGA	I

Note 1. C : Commercial, I : Industrial

ABSOLUTE MAXIMUM RATINGS (1)

Symbol	Parameter	Rating	Unit	Remark
V _{IN} , V _{OUT}	Input/Output Voltage	-0.3 to V _{CC} +0.3	V	
V _{CC}	Power Supply	-0.3 to 2.6V	V	
T _A	Operating Temperature	0 to 70	°C	HY62SF16804B-C
		-40 to 85	°C	HY62SF16804B-I
T _{STG}	Storage Temperature	-55 to 150	°C	
P _D	Power Dissipation	1.0	W	
T _{SOLDER}	Ball Soldering Temperature & Time	260 • 10	°C • sec	

Note

- Stresses greater than those listed under ABSOLUTE MAXIMUM RATINGS may cause permanent damage to the device. This is stress rating only and the functional operation of the device under these or any other conditions above those indicated in the operation of this specification is not implied. Exposure to the absolute maximum rating conditions for extended period may affect reliability.

TRUTH TABLE

/CS	/WE	/OE	/LB	/UB	Mode	I/O		Power
						I/O1~I/O8	I/O9~I/O16	
H	X	X	X	X	Deselected	High-Z	High-Z	Standby
X	X	X	H	H	Deselected	High-Z	High-Z	Standby
L	H	H	L	X	Output Disabled	High-Z	High-Z	Active
L	H	H	X	L	Output Disabled	High-Z	High-Z	Active
L	H	L	L	H	Read	DOUT	High-Z	Active
			H	L		High-Z	DOUT	
			L	L		DOUT	DOUT	
L	L	X	L	H	Write	DIN	High-Z	Active
			H	L		High-Z	DIN	
			L	L		DIN	DIN	

Note:

- H=V_{IH}, L=V_{IL}, X=don't care(V_{IH} or V_{IL})
- UB, LB(Upper, Lower Byte enable)
 These active LOW inputs allow individual bytes to be written or read.
 When LB is LOW, data is written or read to the lower byte, I/O1 -I/O8.
 When UB is LOW, data is written or read to the upper byte, I/O9 -I/O16.

RECOMMENDED DC OPERATING CONDITION

Symbol	Parameter	Min.	Typ.	Max.	Unit
V _{CC}	Supply Voltage	1.65	1.8	2.3	V
V _{SS}	Ground	0	0	0	V
V _{IH}	Input High Voltage	1.4		V _{CC} +0.3	V
V _{IL}	Input Low Voltage	-0.3(1)	-	0.4	V

Note : 1. V_{IL} = -1.5V for pulse width less than 30ns

DC ELECTRICAL CHARACTERISTICS

V_{CC} = 1.65V~2.3V, T_A = 0°C to 70°C / -40°C to 85°C

Sym	Parameter	Test Condition	Min.	Typ.	Max.	Unit	
I _{LI}	Input Leakage Current	V _{SS} ≤ V _{IN} ≤ V _{CC}	-1	-	1	uA	
I _{LO}	Output Leakage Current	V _{SS} ≤ V _{OUT} ≤ V _{CC} , /CS = V _{IH} or /OE = V _{IH} or /WE = V _{IL} , /UB = /LB = V _{IH}	-1	-	1	uA	
I _{CC}	Operating Power Supply Current	/CS = V _{IL} , V _{IN} = V _{IH} or V _{IL} , I _{I/O} = 0mA	-		3	mA	
I _{CC1}	Average Operating Current	Cycle Time=Min, 100% duty, I _{I/O} = 0mA, /CS = V _{IL} , V _{IN} = V _{IH} or V _{IL}		-	15	mA	
		Cycle time = 1us, 100% duty, I _{I/O} = 0mA, /CS ≤ 0.2V, V _{IN} < 0.2V		-	2	mA	
I _{SB}	TTL Standby Current (TTL Input)	/CS = V _{IH} or /UB=/LB= V _{IH} , V _{IN} = V _{IH} or V _{IL}	-	-	300	uA	
I _{SB1}	Standby Current (CMOS Input)	/CS ≥ V _{CC} - 0.2V or /UB=/LB ≥ V _{CC} -0.2V, V _{IN} ≥ V _{CC} -0.2V or V _{IN} ≤ V _{SS} +0.2V	SL	-	-	8	uA
			LL		1	15	
V _{OL}	Output Low Voltage	I _{OL} = 0.1mA	-	-	0.2	V	
V _{OH}	Output High Voltage	I _{OH} = -0.1mA	1.4	-	-	V	

Note : 1. Typical values are at V_{CC} = 1.8V, T_A = 25°C
 2. Typical values are sampled and not 100% tested

CAPACITANCE

(Temp = 25°C, f = 1.0MHz)

Symbol	Parameter	Condition	Max.	Unit
C _{IN}	Input Capacitance(Add, /CS, /WE, /UB, /LB, /OE)	V _{IN} = 0V	8	pF
C _{OUT}	Output Capacitance(I/O)	V _{I/O} = 0V	10	pF

Note : These parameters are sampled and not 100% tested

AC CHARATERISTICS

V_{cc} = 1.65V~2.3V, T_A = 0°C to 70°C / -40°C to 85°C

#	Symbol	Parameter	-70		-85		-10		Unit
			Min.	Max.	Min.	Max.	Min	Max.	
READ CYCLE									
1	t _{RC}	Read Cycle Time	70	-	85	-	100	-	ns
2	t _{AA}	Address Access Time	-	70	-	85	-	100	ns
3	t _{ACS}	Chip Select Access Time	-	70	-	85	-	100	ns
4	t _{OE}	Output Enable to Output Valid	-	35	-	40	-	45	ns
5	t _{BA}	/LB, /UB Access Time	-	70	-	85	-	100	ns
6	t _{CLZ}	Chip Select to Output in Low Z	10	-	10	-	10	-	ns
7	t _{OLZ}	Output Enable to Output in Low Z	5	-	5	-	5	-	ns
8	t _{BLZ}	/LB, /UB Enable to Output in Low Z	10	-	10	-	10	-	ns
9	t _{CHZ}	Chip Deselection to Output in High Z	0	20	0	30	0	30	ns
10	t _{OHZ}	Out Disable to Output in High Z	0	20	0	30	0	30	ns
11	t _{BHZ}	/LB, /UB Disable to Output in High Z	0	20	0	30	0	30	ns
12	t _{OH}	Output Hold from Address Change	10	-	10	-	15	-	ns
WRITE CYCLE									
13	t _{WC}	Write Cycle Time	70	-	85	-	100	-	ns
14	t _{CW}	Chip Selection to End of Write	60	-	70	-	80	-	ns
15	t _{AW}	Address Valid to End of Write	60	-	70	-	80	-	ns
16	t _{BW}	/LB, /UB Valid to End of Write	60	-	70	-	80	-	ns
17	t _{AS}	Address Set-up Time	0	-	0	-	0	-	ns
18	t _{WP}	Write Pulse Width	50	-	60	-	70	-	ns
19	t _{WR}	Write Recovery Time	0	-	0	-	0	-	ns
20	t _{WHZ}	Write to Output in High Z	0	20	0	25	0	25	ns
21	t _{DW}	Data to Write Time Overlap	30	-	35	-	45	-	ns
22	t _{DH}	Data Hold from Write Time	0	-	0	-	0	-	ns
23	t _{OW}	Output Active from End of Write	5	-	5	-	10	-	ns

AC TEST CONDITIONS

T_A = 0°C to 70°C / -40°C to 85°C, unless otherwise specified

PARAMETER		Value
Input Pulse Level		0.2V to V _{cc} -0.2V
Input Rise and Fall Time		5ns
Input and Output Timing Reference Level		0.9V
Output Load	t _{CLZ} , t _{OLZ} , t _{BLZ} , t _{CHZ} , t _{OHZ} , t _{BHZ} , t _{WHZ} , t _{OW}	CL = 30pF + 1TTL Load
	Other	CL = 30pF + 1TTL Load

AC TEST LOADS

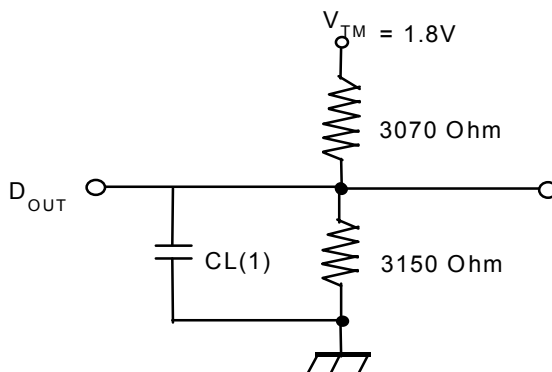

Note

1. Including jig and scope capacitance

TIMING DIAGRAM

READ CYCLE 1(Note 1,4)

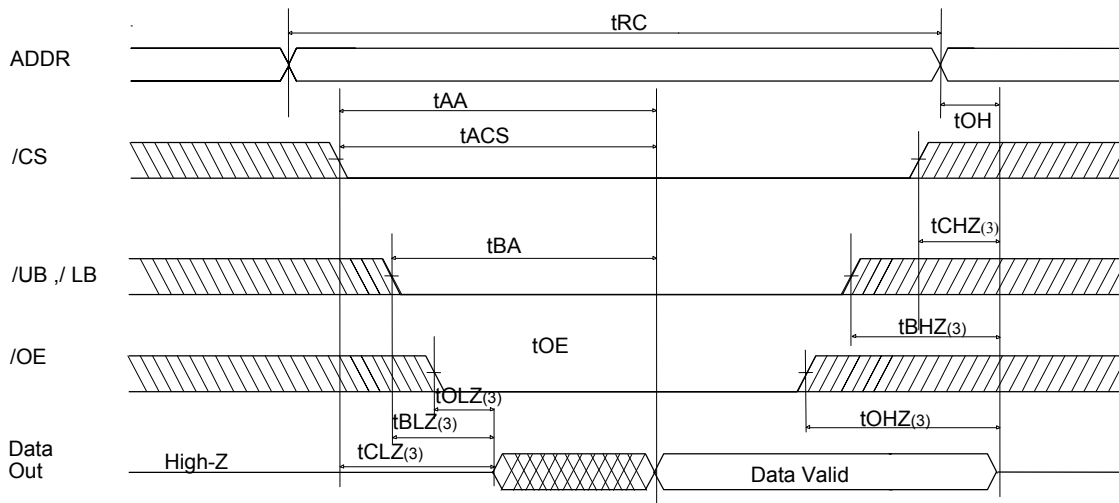

READ CYCLE 2(Note 1,2,4)

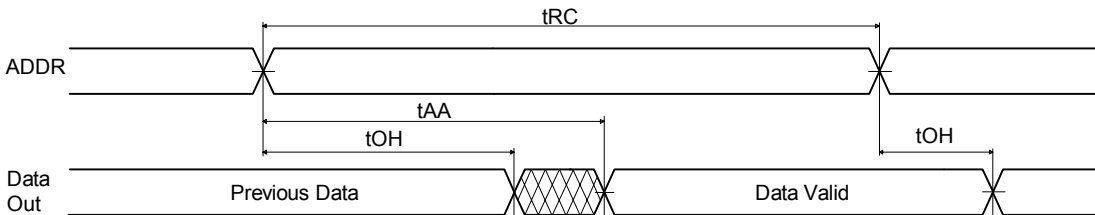

READ CYCLE 3(Note 1,2,4)

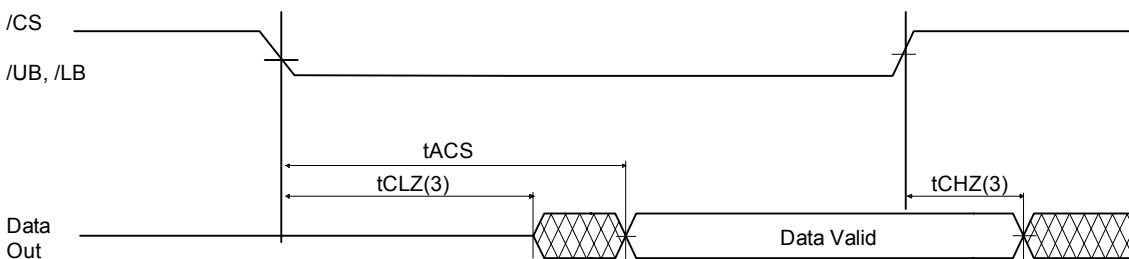

Notes:

1. A read occurs during the overlap of a low /OE, a high /WE, a low /CS and low /UB and /or /LB
2. /OE = VIL
3. tCHZ and tOHZ are defined as the time at which the outputs achieve the open circuit conditions and are not referenced to output voltage levels.
4. /CS in high for the standby, low for active
/UB and /LB in high for the standby, low for active

WRITE CYCLE 1 (1,4,8) (/WE Controlled)

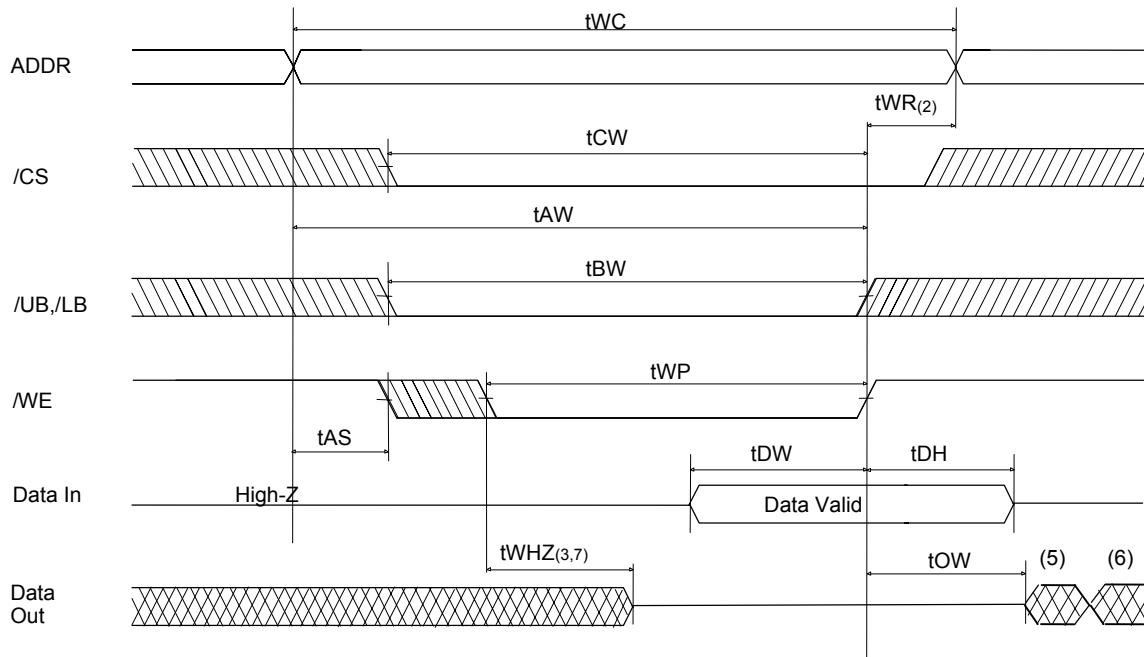

WRITE CYCLE 2 (Note 1,4,8) (/CS Controlled)

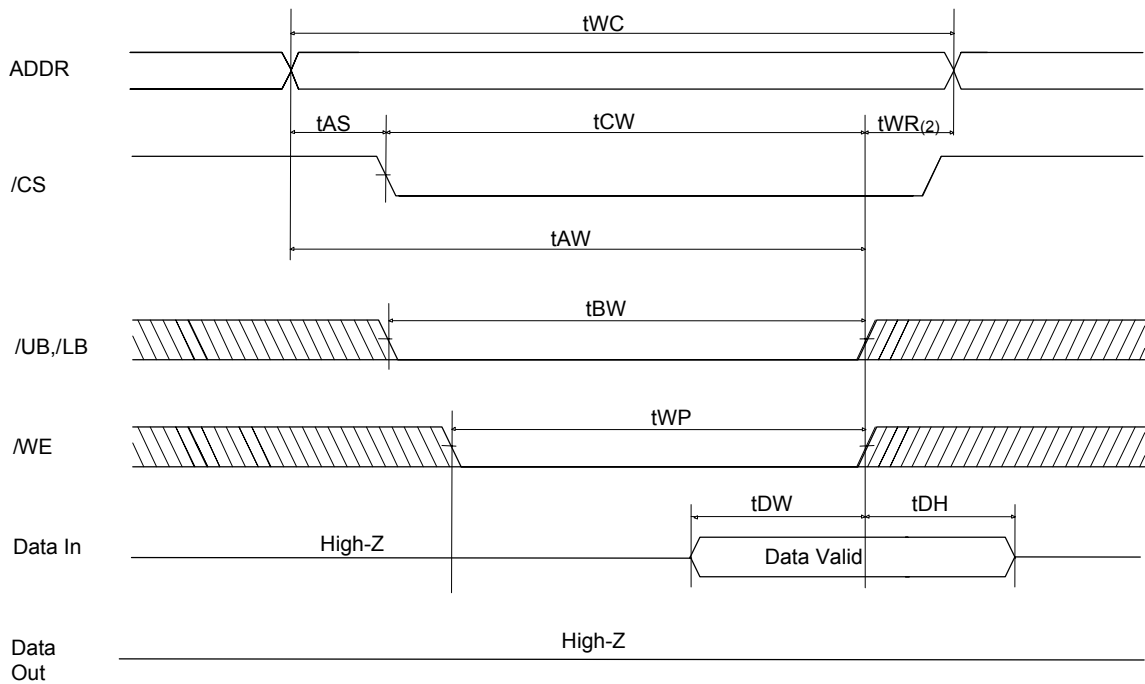

Notes:

1. A write occurs during the overlap of a low /WE, a low /CS1 and low /UB and /or /LB
2. tWR is measured from the earlier of /CS, /LB, /UB, or /WE going high to the end of write cycle.
3. During this period, I/O pins are in the output state so that the input signals of opposite phase to the output must not be applied.
4. If the /CS, /LB and /UB low transition occur simultaneously with the /WE low transition or after the /WE transition, outputs remain in a high impedance state.
5. Q(data out) is the same phase with the write data of this write cycle.
6. Q(data out) is the read data of the next address.
7. /CS in high for the standby, low for active
/UB and /LB in high for the standby, low for active

DATA RETENTION ELECTRIC CHARACTERISTIC

TA = 0°C to 70°C / -40°C to 85°C

Symbol	Parameter	Test Condition	Min	Typ	Max	Unit	
VDR	Vcc for Data Retention	/CS ≥ Vcc - 0.2V or /UB=/LB ≥ Vcc-0.2V, VIN ≥ Vcc-0.2V or VIN ≤ Vss+0.2V	1.2	-	2.3	V	
ICCDR	Data Retention Current	Vcc=1.5V, /CS ≥ Vcc - 0.2V or /UB=/LB ≥ Vcc-0.2V, VIN ≥ Vcc-0.2V or VIN ≤ Vss+0.2V	LL	-	1	12	uA
			SL	-	-	8	uA
tCDR	Chip Deselect to Data Retention Time	See Data Retention Timing Diagram	0	-	-	ns	
tR	Operating Recovery Time		tRC(2)	-	-	ns	

Notes:

1. Typical values are under the condition of TA = 25°C .
2. tRC is read cycle time.

DATA RETENTION TIMING DIAGRAM

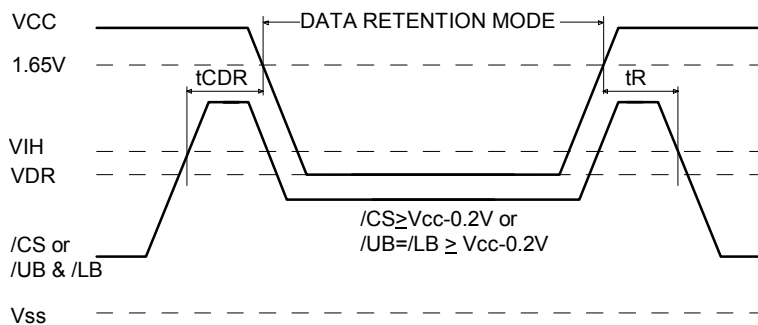

PACKAGE INFORMATION

48ball Fine Pitch Ball Grid Array Package (F)

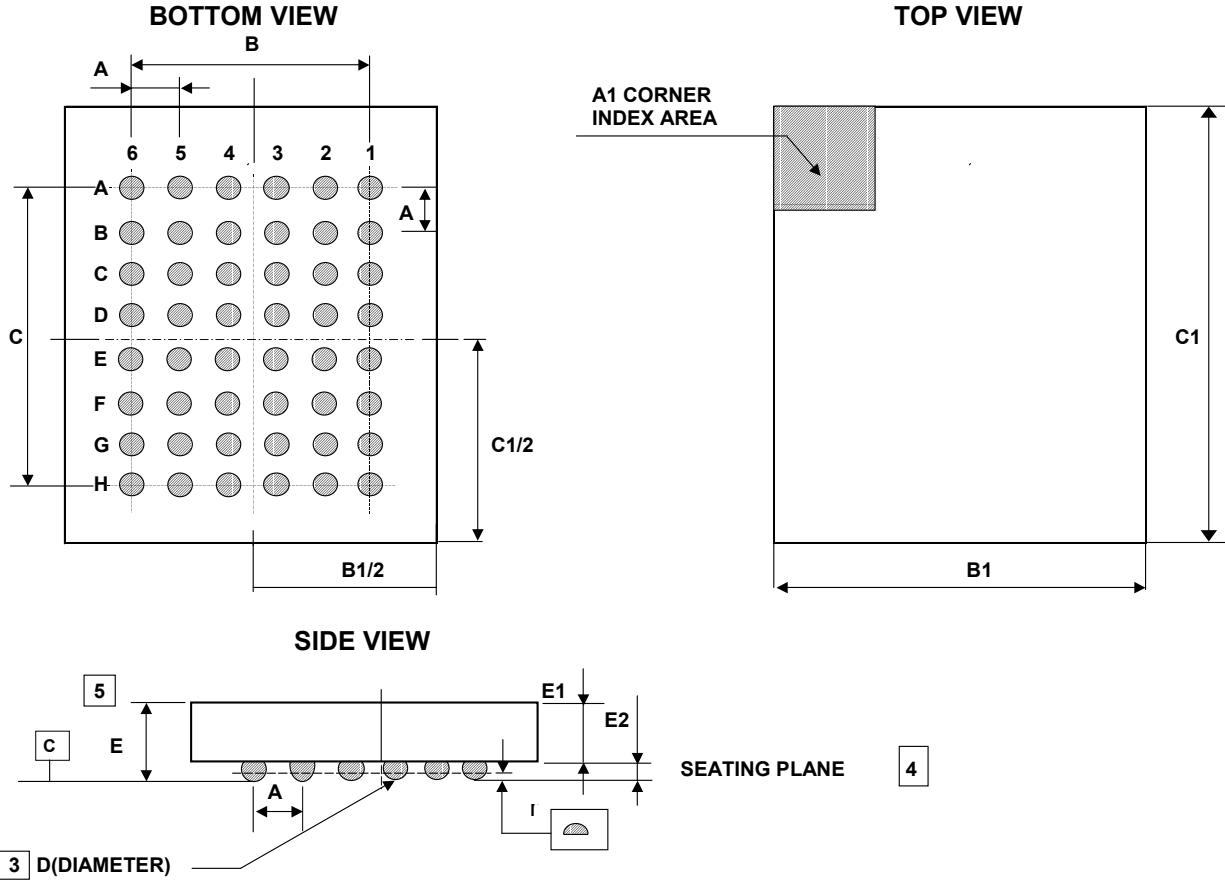

Symbol	Min.	Typ.	Max.
A	-	0.75	-
B	-	3.75	-
B1	5.9	6.0	6.1
C	-	5.25	-
C1	8.4	8.5	8.6
D	0.3	0.35	0.4
E	0.9	1.0	1.10
E1	-	0.76	-
E2	0.20	0.25	0.30
r	-	-	0.08

Note

1. DIMENSIONING AND TOLERANCING PER ASME Y14. 5M-1994.
2. ALL DIMENSIONS ARE MILLIMETERS.
3. DIMENSION "D" IS MEASURED AT THE MAXIMUM SOLDER BALL DIAMETER IN A PLANE PARALLEL TO DATUM C.
4. PRIMARY DATUM C(SEATING PLANE) IS DEFINED BY THE CROWN OF THE SOLDER BALLS.
5. THIS IS A CONTROLLING DIMENSION.

MARKING INSTRUCTION

Package	Marking Example
fBGA	<div style="display: flex; flex-direction: column; align-items: center;"> <div style="display: flex; justify-content: space-around; width: 100%;"> HYSF6804B </div> <div style="display: flex; justify-content: space-around; width: 100%; margin-top: 10px;"> cssstywwpp </div> <div style="display: flex; justify-content: space-around; width: 100%; margin-top: 10px;"> xxxxxKOR </div> <div style="margin-top: 10px;">○</div> </div>

Index

• HYSF6804B	: Part Name
• c	: Power Consumption - D : Low Low Power - S : Super Low Power
• ss	: Speed - 70 : 70ns - 85 : 85ns - 10 : 100ns
• t	: Temperature - C : Commercial (0 ~ 70 °C) - I : Industrial (-40 ~ 85 °C)
• y	: Year (ex : 0 = year 2000, 1= year 2001)
• ww	: Work Week (ex : 12 = work week 12)
• p	: Process Code
• xxxxx	: Lot No.
• KOR	: Origin Country
Note	
- Capital Letter	: Fixed Item
- Small Letter	: Non-fixed Item