

DO NOT SCALE FROM THIS PRINT

SFLX-1XX-XX-X-D-X

- No OF POSITIONS
-10 THRU -50
(PER ROW)
- LEAD STYLE
- 02: SURFACE MOUNT
(USE C-44-02-XXX)
- L2: SURFACE MOUNT
(LOW INSERTION)
(USE C-61-02-XXX)
- T2: SURFACE MOUNT
(PHOS BRONZE)
(USE C-119-02-XXX)

- OPTIONS
- N: NO POLARIZATION NOTCH
(USE SFM-XX-D-FL-N)
- TR: TAPE & REEL PACKAGING
(SEE FIG. 3, SHT. 2)
- K: POLYIMIDE FILM PAD (.005 THICKNESS WITH SILICONE ADHESIVE)
(SEE FIG. 2, SHT. 2)
- P: PICK AND PLACE PAD
(SEE FIG. 2, SHT. 2)
- BODY SPECIFICATION
- D: DOUBLE ROW
(USE SFM-XX-D-FL)
- PLATING SPECIFICATION
- S: SELECTIVE (USE C-XX-02-S)

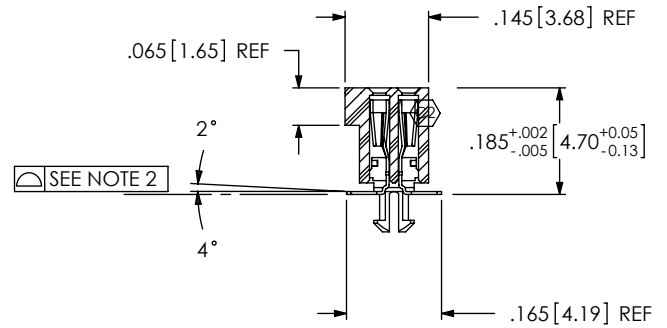
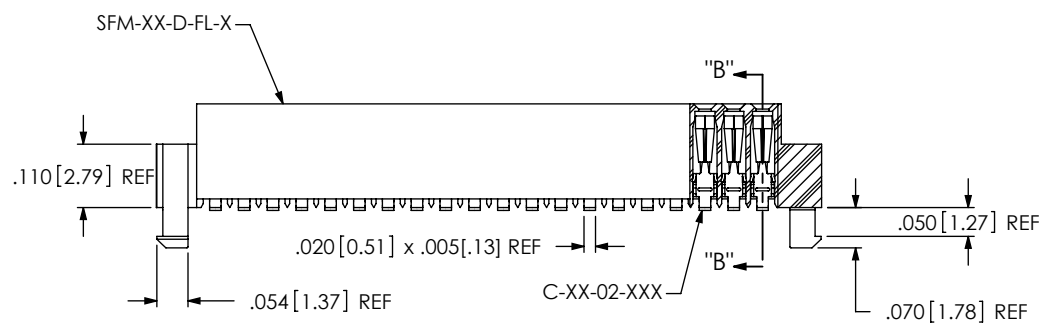
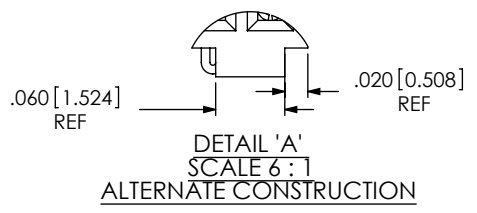
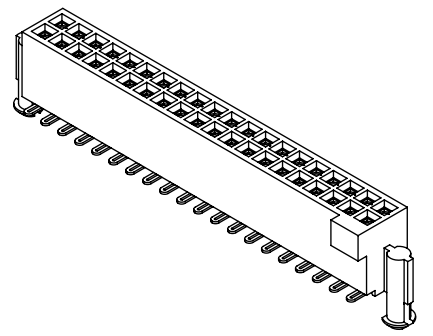
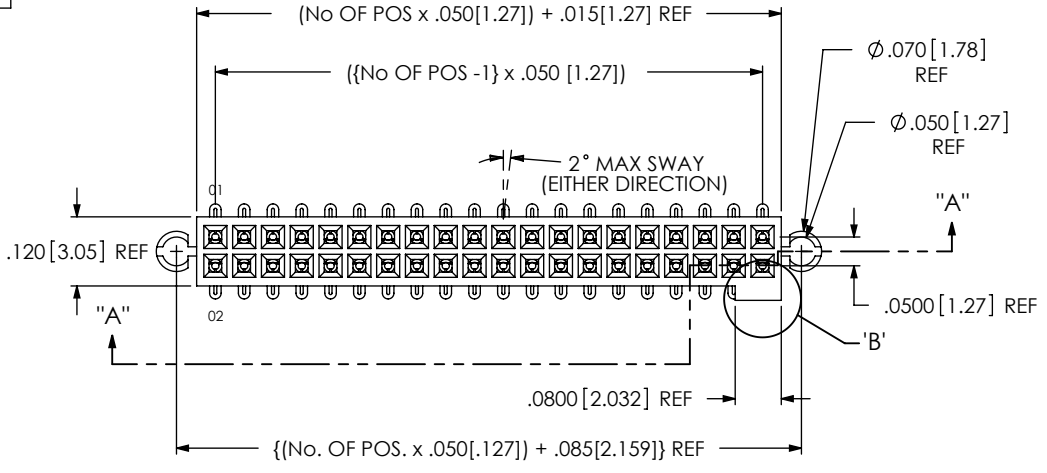

- NOTES:
1. MIN. PUSHOUT FORCE: .5 lb.
 2. COPLANARITY: .004 [.10] FOR POS. 10 THRU 26
.006 [.15] FOR POS. 27 THRU 50
 3. Ⓢ REPRESENTS A CRITICAL DIMENSION.
 4. NOTE DELETED.
 5. MAX BOW: .002 in/in AFTER ASSEMBLY

UNLESS OTHERWISE SPECIFIED, DIMENSIONS ARE IN INCHES. TOLERANCES ARE:

DECIMALS	ANGLES
.XX: $\pm .01 [3]$	2°
.XXX: $\pm .005 [13]$	
.XXXX: $\pm .0020 [051]$	

PROPRIETARY NOTE
THIS DOCUMENT CONTAINS INFORMATION CONFIDENTIAL AND PROPRIETARY TO SAMTEC, INC. AND SHALL NOT BE REPRODUCED OR TRANSFERRED TO OTHER DOCUMENTS OR DISCLOSED TO OTHERS OR USED FOR ANY PURPOSE OTHER THAN THAT WHICH IT WAS OBTAINED WITHOUT THE EXPRESSED WRITTEN CONSENT OF SAMTEC, INC.



520 PARK EAST BLVD, NEW ALBANY, IN 47150
PHONE: 812-944-6733 FAX: 812-948-5047
e-Mail: info@SAMTEC.com code 55322

DO NOT SCALE DRAWING SHEET SCALE: 3:1

MATERIAL:
INSULATOR: BLACK, LCP
CONTACT: BeCu OR PHOS BRONZE

F:\DWG\MISC\MKTG\SFLX-1XX-XX-X-D-X-MKT.SLDRW

DESCRIPTION:
FLEX LATCH/LOCKING SOCKET STRIP ASM

DWG. NO.
SFLX-1XX-XX-X-D-X

BY: T.WERNE 11/13/01 SHEET 1 OF 2

FIG. 2
-K & -P VIEWS

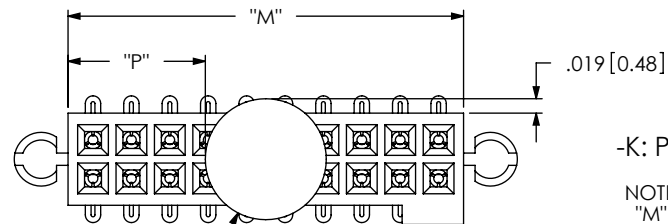

-K: POLYIMIDE FILM PAD OPTION

NOTE:

"M" = USED MEASURED DIMENSION (REF)
"P" = $\{("M" - .1575[4.000]) / 2\} \pm .020[.51]$

$\varnothing .1575 [4.00]$
K-500-300

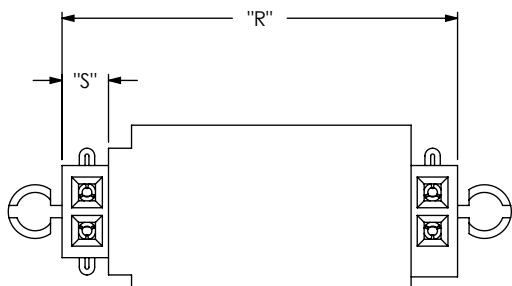
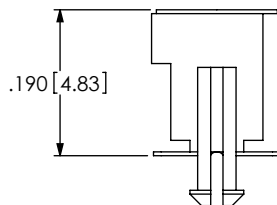
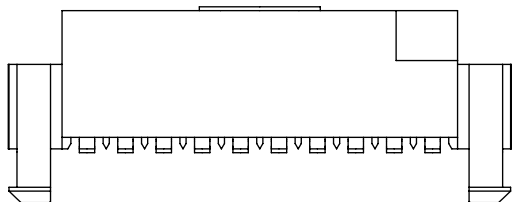

-P: PICK AND PLACE PAD

NOTE:

"R" = USED MEASURED DIMENSION (REF)
"S" = $\{("R" - .394 [10.01]) / 2\} \pm .020[.51]$

PPP-02

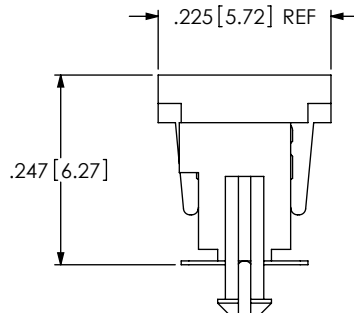
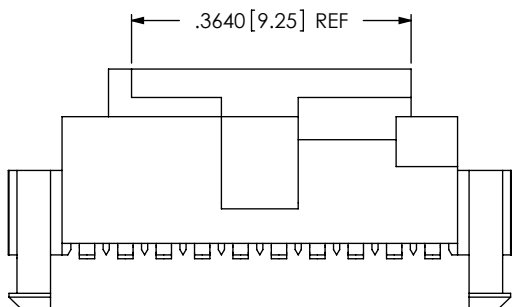
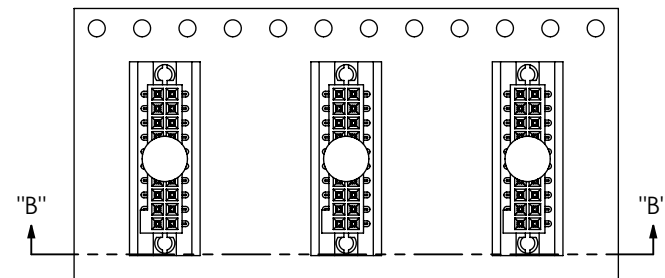
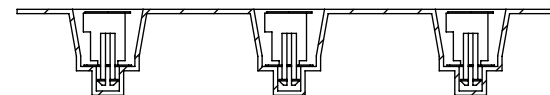

FIG. 3
PACKAGING VIEWS

-TR: TAPE & REEL
PACKAGING



USER DIRECTION OF UN-REELING
POCKET NOT DETAILED



SECTION "B"- "B"
SCALE 3 : 2

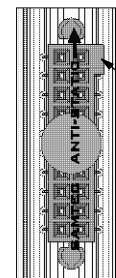

POLARIZATION NOTCH

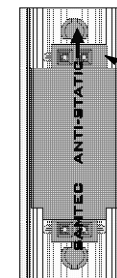

POLARIZATION NOTCH

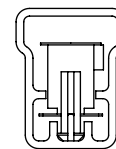

-K OPTION

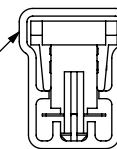

-P OPTION

TUBE PACKAGING

NOTE:

ALL PARTS MUST BE ORIENTED WITH POS 1 IN THE SAME DIRECTION AS THE ARROW.

PROPRIETARY NOTE

THIS DOCUMENT CONTAINS INFORMATION CONFIDENTIAL AND PROPRIETARY TO SAMTEC, INC. AND SHALL NOT BE REPRODUCED OR TRANSFERRED TO OTHER DOCUMENTS OR DISCLOSED TO OTHERS OR USED FOR ANY PURPOSE OTHER THAN THAT WHICH IT WAS OBTAINED WITHOUT THE EXPRESSED WRITTEN CONSENT OF SAMTEC, INC.

DO NOT SCALE DRAWING

SHEET SCALE: 4:1

samtec

520 PARK EAST BLVD, NEW ALBANY, IN 47150
PHONE: 812-944-6733 FAX: 812-948-5047
e-Mail: info@SAMTEC.com code 55322

DESCRIPTION:
FLEX LATCH/LOCKING SOCKET STRIP ASM

DWG. NO. SFLX-1XX-XX-X-D-X

BY: T.WERNE 11/13/01 SHEET 2 OF 2