

# MAX811, MAX812

## 4-Pin $\mu$ P Reset Monitors

The MAX811 and MAX812 are cost-effective system supervisor circuits designed to monitor  $V_{CC}$  in digital systems and provide a reset signal to the host processor when necessary. A manual reset input is provided to override the reset monitor, and is suitable for use as a push-button reset. No external components are required.

The reset output is driven active within 20  $\mu$ sec (4  $\mu$ sec for F version) of  $V_{CC}$  falling through the reset voltage threshold. RESET is maintained active for a minimum of 140 msec after  $V_{CC}$  rises above the reset threshold. The MAX812 has an active-high RESET output while the MAX811 has an active-low RESET output. The output of the MAX811 is guaranteed valid down to  $V_{CC} = 1$  V. Both devices are available in a 4-Pin SOT-143 package.

The MAX811/12 are optimized to reject fast transient glitches on the  $V_{CC}$  line. Low supply current of 7  $\mu$ A ( $V_{CC} = 3.3$  V) makes these devices suitable for battery powered applications.

### Features

- Precision  $V_{CC}$  Monitor for 1.8 V, 2.7 V, 3.0 V, 3.3 V, 5.0 V Nominal Supplies
- Manual Reset Input
- 140 msec Guaranteed Minimum  $\overline{\text{RESET}}$ , RESET Output Duration
- $\overline{\text{RESET}}$  Output Guaranteed to  $V_{CC} = 1.0$  V (MAX811)
- Low 7  $\mu$ A Supply Current
- $V_{CC}$  Transient Immunity
- Small SOT-143-4 Package
- No External Components

### Typical Applications

- Computers
- Embedded Systems
- Battery Powered Equipment
- Critical  $\mu$ P Power Supply Monitoring

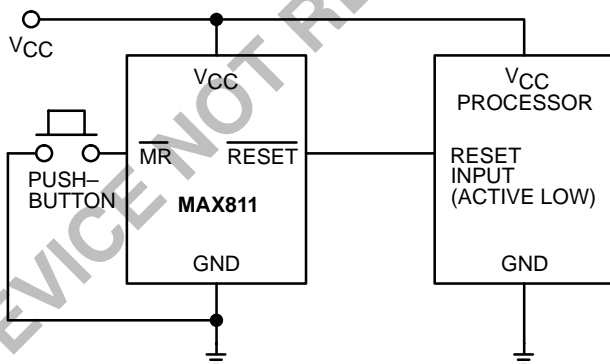

Typical Operating Circuit



ON Semiconductor®

<http://onsemi.com>

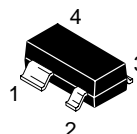

SOT-143  
CASE 318A

### PIN CONNECTIONS

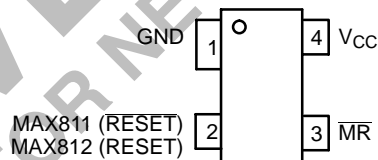

### ORDERING INFORMATION

See detailed ordering and shipping information in the package dimensions section on page 6 of this data sheet.

### DEVICE MARKING INFORMATION

See general marking information in the device marking section on page 6 of this data sheet.

# MAX811, MAX812

## MAXIMUM RATINGS\*

Rating	Symbol	Value	Unit
Supply Voltage ( $V_{CC}$ to GND)	–	+6.0	V
RESET, RESET	–	–0.3 to ( $V_{CC} + 0.3$ )	V
Input Current, $V_{CC}$	–	20	mA
Output Current, RESET, RESET	–	20	mA
Operating Temperature Range	$T_A$	–40 to +85	°C
Storage Temperature Range	$T_{stg}$	–65 to +150	°C
Lead Temperature (Soldering, 10 sec)	–	+260	°C

\*This is a stress rating only and functional operation of the device at these or any other conditions above those indicated in the operational sections of the specifications is not implied. Exposure to absolute maximum rating conditions for extended periods may affect device reliability.

**ELECTRICAL CHARACTERISTICS** ( $V_{CC} = 5$  V for L/M versions,  $V_{CC} = 3.3$  V for T/S versions,  $V_{CC} = 3$  V for R version,  $V_{CC} = 2.0$  V for F version.  $T_A = -40^\circ\text{C}$  to  $+85^\circ\text{C}$  unless otherwise noted. Typical values are at  $T_A = +25^\circ\text{C}$ .) (Note 1)

Characteristics	Test Conditions	Symbol	Min	Typ	Max	Unit
$V_{CC}$ Range	–	$V_{CC}$	1.2	–	5.5	V
Supply Current	$V_{CC} > V_{TH}$ , for L, M, R, S, T, F $V_{CC} < V_{TH}$ , for L, M, R, S, T $V_{CC} < V_{TH}$ , for F	$I_{CC}$	–	7.0 10 6.0	15 15 12	$\mu\text{A}$
Reset Threshold	MAX81_L: $T_A = +25^\circ\text{C}$ $T_A = -40^\circ\text{C}$ to $+85^\circ\text{C}$ MAX81_M: $T_A = +25^\circ\text{C}$ $T_A = -40^\circ\text{C}$ to $+85^\circ\text{C}$ MAX81_T: $T_A = +25^\circ\text{C}$ $T_A = -40^\circ\text{C}$ to $+85^\circ\text{C}$ MAX81_S: $T_A = +25^\circ\text{C}$ $T_A = -40^\circ\text{C}$ to $+85^\circ\text{C}$ MAX81_R: $T_A = +25^\circ\text{C}$ $T_A = -40^\circ\text{C}$ to $+85^\circ\text{C}$ MAX81_F: $T_A = +25^\circ\text{C}$ $T_A = -40^\circ\text{C}$ to $+85^\circ\text{C}$	$V_{TH}$	4.54 4.50 4.30 4.25 3.03 3.00 2.88 2.85 2.58 2.55 1.71 1.70	4.63 – 4.38 – 3.08 – 2.93 – 2.63 – 1.75 –	4.72 4.75 4.46 4.50 3.14 3.15 2.98 3.00 2.68 2.70 1.79 1.80	V
Reset Threshold Tempco	–	–	–	30	–	ppm/°C
$V_{CC}$ to Reset Delay	$V_{CC} = V_{TH}$ to $V_{TH} - 125$ mV; L, M, R, S, T, F	–	–	20 5.0	– –	$\mu\text{sec}$
Reset Active Timeout Period	$V_{CC} = V_{TH(\text{MAX})}$	$t_{RP}$	140	280	560	msec
MR Minimum Pulse Width	–	$t_{MR}$	10	–	–	$\mu\text{sec}$
MR Glitch Immunity	–	–	–	0.1	–	$\mu\text{sec}$
MR to Reset Propagation Delay	–	$t_{MD}$	–	0.5	–	$\mu\text{sec}$
MR Input Threshold	$V_{CC} > V_{TH(\text{MAX})}$ , MAX81_L/M	$V_{IH}$ $V_{IL}$	2.3 –	– –	– 0.8	V
–	$V_{CC} > V_{TH(\text{MAX})}$ , MAX81_R/S/T/F	$V_{IH}$ $V_{IL}$	$0.7 V_{CC}$ –	– –	– $0.15 V_{CC}$	V
MR Pull-up Resistance	–	–	10	20	40	K $\Omega$
RESET Output Voltage High (MAX812)	$I_{SOURCE} = 150 \mu\text{A}$ ; $V_{CC} \leq V_{TH(\text{MIN})}$	$V_{OH}$	$0.8 V_{CC}$	–	–	V

1. Production testing done at  $T_A = +25^\circ\text{C}$ , over temperature limits guaranteed by design.

## MAX811, MAX812

**ELECTRICAL CHARACTERISTICS (continued)** ( $V_{CC} = 5\text{ V}$  for L/M versions,  $V_{CC} = 3.3\text{ V}$  for T/S versions,  $V_{CC} = 3\text{ V}$  for R version,  $V_{CC} = 2.0\text{ V}$  for F version.  $T_A = -40^\circ\text{C}$  to  $+85^\circ\text{C}$  unless otherwise noted. Typical values are at  $T_A = +25^\circ\text{C}$ .) (Note 1)

Characteristics	Symbol	Test Conditions	Min	Typ	Max	Unit
RESET Output Voltage Low (MAX812)	$V_{OL}$	MAX812F only, $I_{SINK} = 500\ \mu\text{A}$ , $V_{CC} = V_{TH(MAX)}$  MAX812R/S/T only, $I_{SINK} = 1.2\ \text{mA}$ , $V_{CC} = V_{TH(MAX)}$ MAX812L/M only, $I_{SINK} = 3.2\ \text{mA}$ , $V_{CC} = V_{TH(MAX)}$	–	–	0.2	V
RESET Output Voltage Low (MAX811)	$V_{OL}$	MAX811R/S/T only, $I_{SINK} = 1.2\ \text{mA}$ , $V_{CC} = V_{TH(MIN)}$ MAX811F only, $I_{SINK} = 500\ \mu\text{A}$ , $V_{CC} = V_{TH(MIN)}$  MAX811L/M only, $I_{SINK} = 3.2\ \text{mA}$ , $V_{CC} = V_{TH(MIN)}$ $I_{SINK} = 50\ \mu\text{A}$ , $V_{CC} > 1.0\ \text{V}$	–	–	0.3  0.4  TBD	V
RESET Output Voltage High (MAX811)	$V_{OH}$	MAX811L/M only, $I_{SOURCE} = 800\ \mu\text{A}$ , $V_{CC} > V_{TH(MAX)}$ MAX811R/S/T/F only, $I_{SOURCE} = 500\ \mu\text{A}$ , $V_{CC} > V_{TH(MAX)}$	$V_{CC} - 1.5$  0.8 $V_{CC}$	–	–	V

1. Production testing done at  $T_A = +25^\circ\text{C}$ , over temperature limits guaranteed by design.
2. RESET output for MAX811, RESET output for MAX812.

### PIN DESCRIPTION

Pin Number	Symbol	Description
1	GND	Ground
2	RESET (MAX811)	RESET output remains low while $V_{CC}$ is below the reset voltage threshold, and for at least 140 msec min. after $V_{CC}$ rises above reset threshold.
2	RESET (MAX812)	RESET output remains high while $V_{CC}$ is below the reset voltage threshold, and for at least 140 msec min. after $V_{CC}$ rises above reset threshold.
3	$\overline{\text{MR}}$	Manual Reset input generates a reset when $\overline{\text{MR}}$ is below $V_{IL}$ .
4	$V_{CC}$	Supply voltage

APPLICATIONS INFORMATION

V<sub>CC</sub> Transient Rejection

The MAX811/12 provides accurate V<sub>CC</sub> monitoring and reset timing during power-up, power-down, and brownout/sag conditions, and rejects negative-going transients (glitches) on the power supply line. Figure 1 shows the maximum transient duration vs. maximum negative excursion (overdrive) for glitch rejection. Any combination of duration and overdrive that lays **under** the curve will **not** generate a reset signal. Combinations above the curve are detected as a brownout or power-down. Transient immunity can be improved by adding a capacitor in close proximity to the V<sub>CC</sub> pin of the MAX811/12.

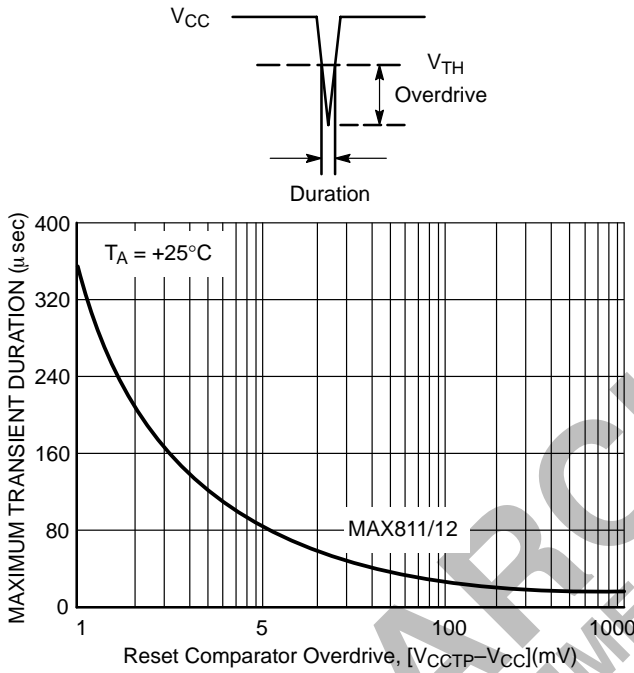

Figure 1. Maximum Transient Duration vs. Overdrive for Glitch Rejection at 25°C

RESET Signal Integrity During Power-Down

The MAX811 RESET output is valid to V<sub>CC</sub> = 1.0 V. Below this voltage the output becomes an “open circuit” and does not sink current. This means CMOS logic inputs to the μP will be floating at an undetermined voltage. Most digital systems are completely shutdown well above this voltage. However, in situations where RESET must be maintained valid to V<sub>CC</sub> = 0 V, a pull-down resistor must be connected from RESET to ground to discharge stray capacitances and hold the output low (Figure 2). This resistor value, though not critical, should be chosen such that it does not appreciably load RESET under normal operation (100 kΩ will be suitable for most applications). Similarly, a pull-up

resistor to V<sub>CC</sub> is required for the MAX812 to ensure a valid high RESET for V<sub>CC</sub> below 1.1 V.

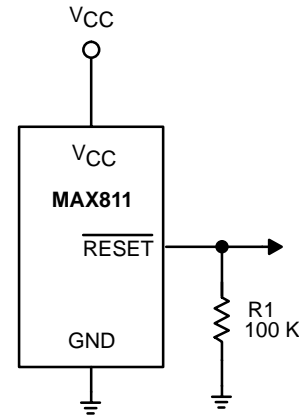

Figure 2. Ensuring RESET Valid to V<sub>CC</sub> = 0 V

Processors with Bidirectional I/O Pins

Some μP's (such as Motorola's 68HC11) have bi-directional reset pins. Depending on the current drive capability of the processor pin, an indeterminate logic level may result if there is a logic conflict. This can be avoided by adding a 4.7 kΩ resistor in series with the output of the MAX811/12 (Figure 3). If there are other components in the system which require a reset signal, they should be buffered so as not to load the reset line. If the other components are required to follow the reset I/O of the μP, the buffer should be connected as shown with the solid line.

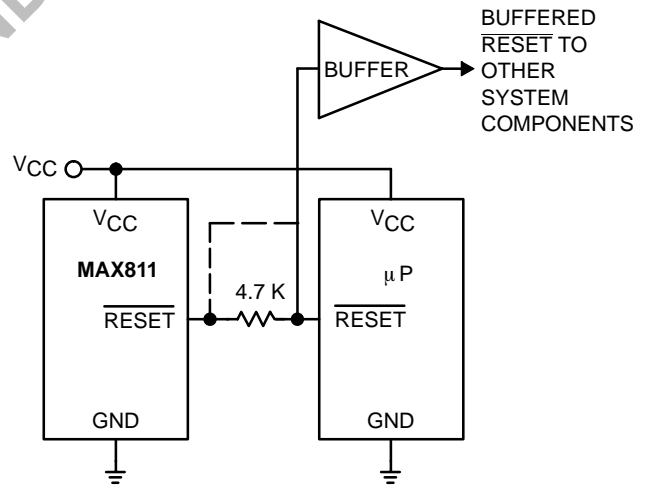

Figure 3. Interfacing to Bidirectional Reset I/O

# MAX811, MAX812

## TYPICAL CHARACTERISTICS

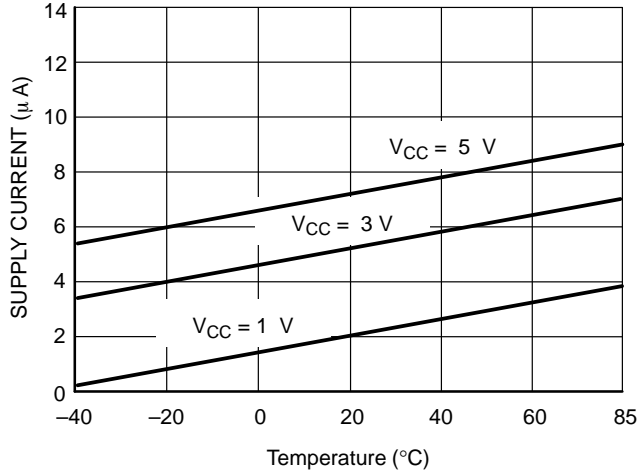

Figure 4. Supply Current vs. Temperature (No Load, MAX81xR/S/T/F)

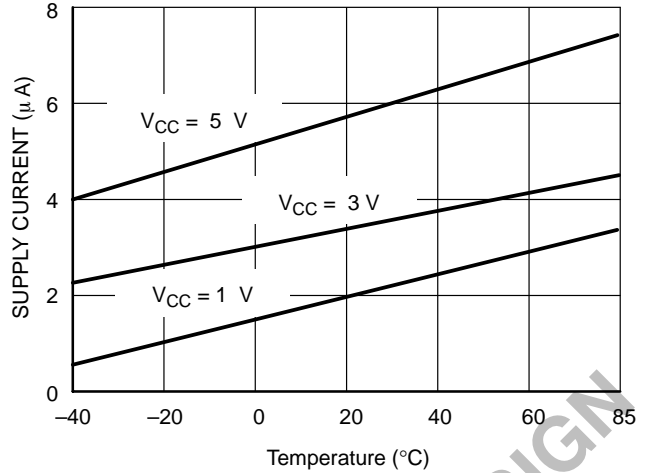

Figure 5. Supply Current vs. Temperature (No Load, MAX81xL/M)

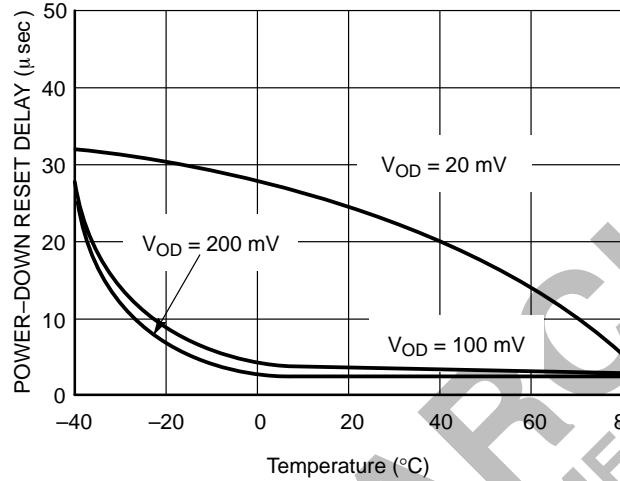

Figure 6. Power-Down Reset Delay vs. Temperature (MAX81xF)

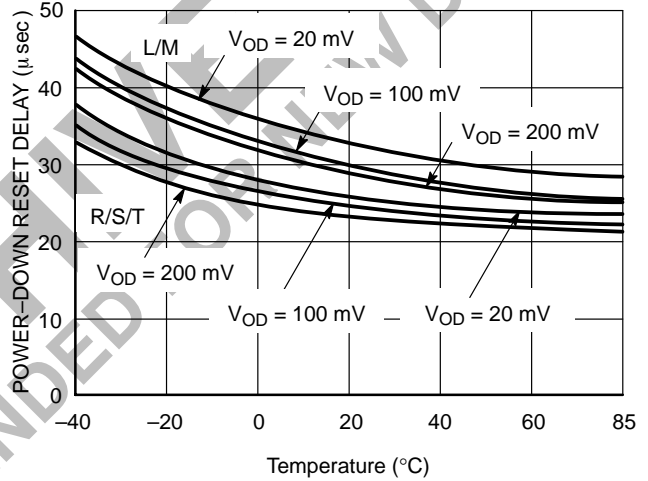

Figure 7. Power-Down Reset Delay vs. Temperature (MAX81xL/M/R/S/T)

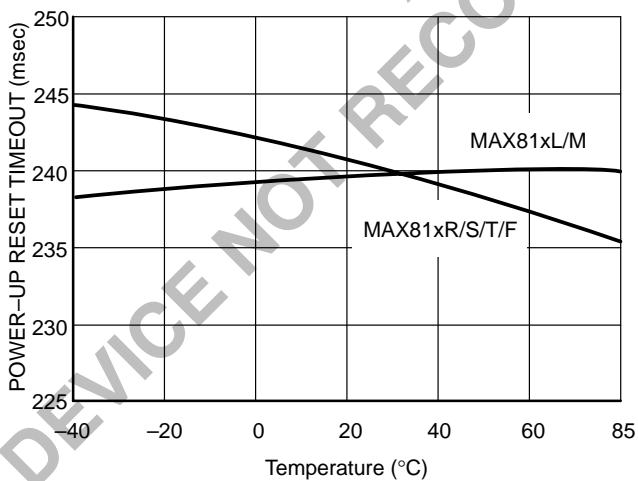

Figure 8. Power-Up Reset Timeout vs. Temperature

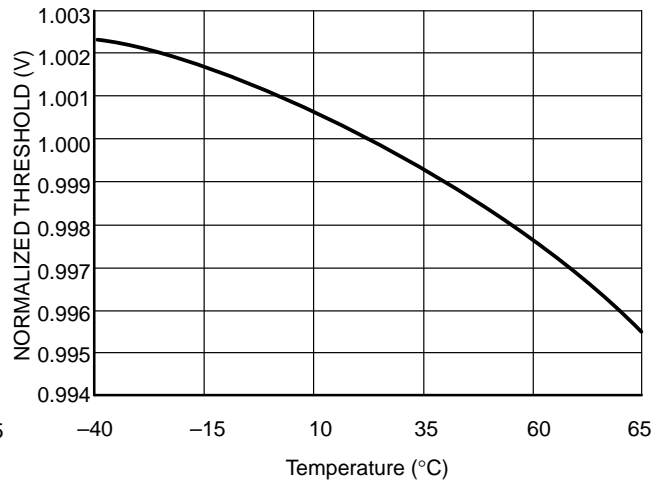
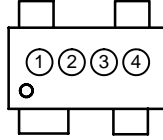

Figure 9. Normalized Reset Threshold vs. Temperature

# MAX811, MAX812

## MARKING DIAGRAM



- ① and ② = Part Number Code and Temperature Range (two-digit code)
- ③ = Year and Quarter Code
- ④ = Lot ID Number

## ORDERING INFORMATION

Device	Threshold Voltage	Marking ① and ②	Package (Qty/Reel)
MAX811LEUS-T*	4.63	S1	3000 Units Tape and Reel
MAX811MEUS-T*	4.38	S2	
MAX811TEUS-T	3.08	S3	
MAX811SEUS-T*	2.93	S4	
MAX811REUS-T*	2.63	S5	
MAX811FEUS-T	1.75	S7	
MAX812LEUS-T*	4.63	T1	
MAX812MEUS-T*	4.38	T2	
MAX812TEUS-T	3.08	T3	
MAX812SEUS-T*	2.93	T4	
MAX812REUS-T*	2.63	T5	
MAX812FEUS-T	1.75	T7	

\*Default: Contact your ON Semiconductor sales representative for other threshold voltage options.

# MAX811, MAX812

## PACKAGE DIMENSIONS

SOT-143  
CASE 318A-05  
ISSUE R

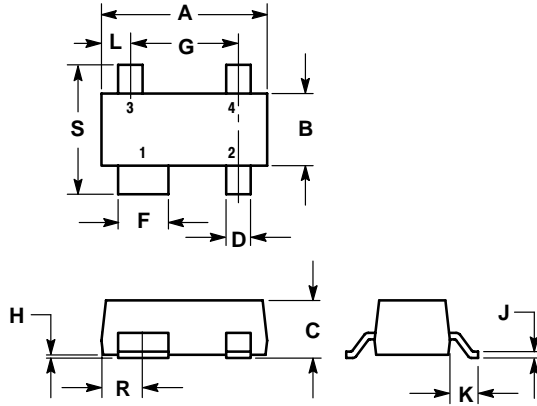

### NOTES:

1. DIMENSIONING AND TOLERANCING PER ANSI Y14.5M, 1982.
2. CONTROLLING DIMENSION: MILLIMETER.

DIM	MILLIMETERS		INCHES	
	MIN	MAX	MIN	MAX
A	2.80	3.04	0.110	0.120
B	1.20	1.39	0.047	0.055
C	0.84	1.14	0.033	0.045
D	0.39	0.50	0.015	0.020
F	0.79	0.93	0.031	0.037
G	1.78	2.03	0.070	0.080
H	0.013	0.10	0.0005	0.004
J	0.08	0.15	0.003	0.006
K	0.46	0.60	0.018	0.024
L	0.445	0.60	0.0175	0.024
R	0.72	0.83	0.028	0.033
S	2.11	2.48	0.083	0.098

ARCHIVE  
DEVICE NOT RECOMMENDED FOR NEW DESIGN

ARCHIVE  
RECOMMENDED FOR NEW DESIGN

ON Semiconductor and  are registered trademarks of Semiconductor Components Industries, LLC (SCILLC). SCILLC reserves the right to make changes without further notice to any products herein. SCILLC makes no warranty, representation or guarantee regarding the suitability of its products for any particular purpose, nor does SCILLC assume any liability arising out of the application or use of any product or circuit, and specifically disclaims any and all liability, including without limitation special, consequential or incidental damages. "Typical" parameters which may be provided in SCILLC data sheets and/or specifications can and do vary in different applications and actual performance may vary over time. All operating parameters, including "Typicals" must be validated for each customer application by customer's technical experts. SCILLC does not convey any license under its patent rights nor the rights of others. SCILLC products are not designed, intended, or authorized for use as components in systems intended for surgical implant into the body, or other applications intended to support or sustain life, or for any other application in which the failure of the SCILLC product could create a situation where personal injury or death may occur. Should Buyer purchase or use SCILLC products for any such unintended or unauthorized application, Buyer shall indemnify and hold SCILLC and its officers, employees, subsidiaries, affiliates, and distributors harmless against all claims, costs, damages, and expenses, and reasonable attorney fees arising out of, directly or indirectly, any claim of personal injury or death associated with such unintended or unauthorized use, even if such claim alleges that SCILLC was negligent regarding the design or manufacture of the part. SCILLC is an Equal Opportunity/Affirmative Action Employer.

## PUBLICATION ORDERING INFORMATION

### Literature Fulfillment:

Literature Distribution Center for ON Semiconductor  
P.O. Box 5163, Denver, Colorado 80217 USA  
Phone: 303-675-2175 or 800-344-3860 Toll Free USA/Canada  
Fax: 303-675-2176 or 800-344-3867 Toll Free USA/Canada  
Email: ONlit@hibbertco.com

N. American Technical Support: 800-282-9855 Toll Free USA/Canada

JAPAN: ON Semiconductor, Japan Customer Focus Center  
4-32-1 Nishi-Gotanda, Shinagawa-ku, Tokyo, Japan 141-0031  
Phone: 81-3-5740-2700  
Email: r14525@onsemi.com

ON Semiconductor Website: <http://onsemi.com>

For additional information, please contact your local Sales Representative.