

Weight: 0.30 g Unit: mm

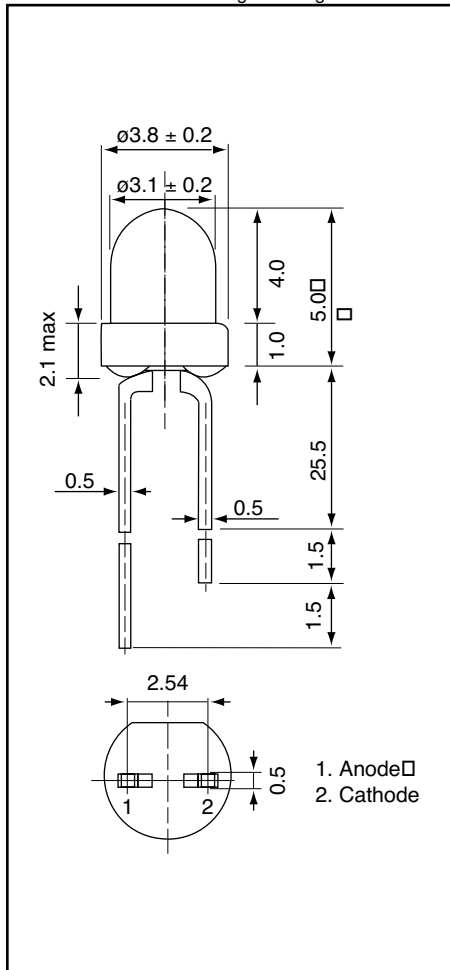

# AND124R

## Standard LED

### T-1 Package (3 mm)

#### Features

- Low power requirement
- Stand-off or flush-mount
- All plastic molded lens
- Color: GaP-Red
- RoHS Compliant

#### Optical Characteristics ( $T_a = 25^\circ\text{C}$ )

Part Number	Color		Lens Desc.	Axial Luminous Intensity (mcd)		Test Condition ( $I_F$ -mA)	Viewing Angle $2\theta_{1/2}$ (deg)
	LED	Lens		Min.	Typ.		
AND124R	Red	Red	Diffused	1.3	3.0	10	60

#### Absolute Maximum Ratings ( $T_a = 25^\circ\text{C}$ )

Characteristics	Symbol	Rating	Unit
Forward Current (DC)	$I_F$	25	mA
Reverse Voltage	$V_R$	5	V
Power Dissipation	$P_D$	120	mW
Operating Temperature	$T_{Opr}$	-40 to +85	$^\circ\text{C}$
Storage Temperature Range	$T_{Stg}$	-40 to +85	$^\circ\text{C}$

#### Electro-Optical Characteristics ( $T_a = 25^\circ\text{C}$ )

Characteristics	Symbol	Test Condition	Red			Unit
			Min.	Typ.	Max.	
Forward Voltage	$V_F$	$I_F = 20\text{mA}$	-	2.0	2.5	V
Reverse Current	$I_R$	$V_R = 5\text{V}$	-	-	10	$\mu\text{A}$
Peak Emission Wavelength	$\lambda_p$	$I_F = 15\text{mA}$	-	700	-	nm
Spectral Line Half Width	$\lambda$	$I_F = 15\text{mA}$	-	45	-	nm

#### Precaution

Please be careful of the following:

1. Soldering temperature:  $260^\circ\text{C}$  max; Soldering time: 3 sec. max; Soldering portion of lead: up to 2 mm from the body of the device.
2. The lead can be formed up to 5 mm from the body of the device without forming stress. Soldering should be performed after the lead forming.

Product specifications contained herein may be changed without prior notice.

It is therefore advisable to contact Purdy Electronics before proceeding with the design of equipment incorporating this product.

