



# PRODUCT SPECIFICATION

REV A January 2011

Oscilent Controlled Document

Ordering Code / Part Number	Product Description
835-IF119.9M-19C	19.90MHz IF SAW Filter 19.14 MHz Bandwidth

## Specification Contents

- o Mechanical Dimensions
- o Test Circuit
- o Maximum Ratings
- o Electrical Specification
- o Frequency Response
- o Smith Chart
- o VSWR

## Notes

- o Electrostatic Sensitive Device (ESD) 
- o Avoid excessive ultrasonic exposure
- o Solderability compatible with JEDEC J-STD-020C Pb-free process, 260°C peak reflow temperature
- o This product complies with EU directive 2002/95/EC (RoHS compliance)





## Mechanical Dimensions (mm)

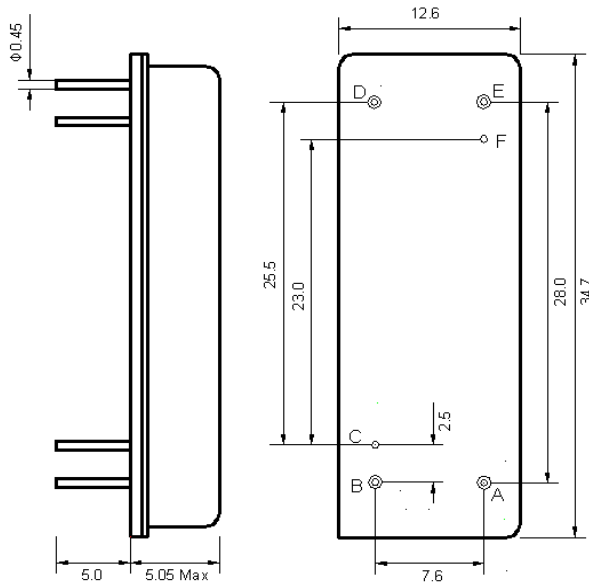

Pin Description	
B, C, D, F	Ground
A	In
E	Out

## Test Circuit

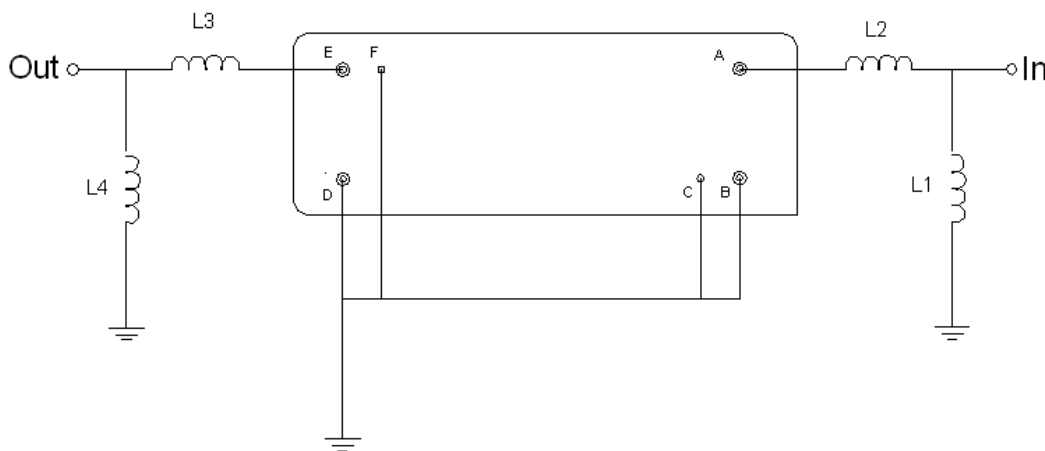

Test Fixture & Values	
Input	L1=27 nH, L2=10 nH
Output	L3=12 nH, L4=22 nH
Source/Load Impedance	50 $\Omega$



## Maximum Ratings

Parameters Description	Unit	Minimum	Typical	Maximum
Operating Temperature Range	°C	-20	-	70
Storage Temperature Range	°C	-40	-	85
Maximum DC Voltage	V	-	-	10
Maximum Input Power	dBm	-	-	10
Source Impedance (single ended) <sup>(1)</sup>	Ω	-	50	-
Load Impedance (single ended) <sup>(1)</sup>	Ω	-	50	-

Notes: With Matching Network (Ref. Testing Environment Circuit as shown above).

Those impedances could be modified with different impedance values and/or structures, if necessary.

## Electrical Specification

Parameters Description	Unit	Minimum	Typical	Maximum
Center Frequency (Fo)	MHz	-	119.9	-
Insertion Loss at Fo	dB	-	28.0	30.0
Group Delay Variation (Fo±9.42MHz)	ns	-	43	90
Absolute Delay Time at Fo	us	-	4.32	-
Temperature Coefficient	ppm/°C	-	-18	-
Amplitude Ripple (Fo±9.42MHz)	dB	-	0.65	2.00
Bandwidth at -1dB	MHz	18.90	19.14	-
Bandwidth at -3dB	MHz	-	19.30	-
Bandwidth at -40dB	MHz	-	20.04	20.18
Relative Attenuation				
Fo ± 10.0MHz	dBc	25	33	-
Ultimate Rejection	dB	50	52	-



### Frequency Response

#### Bandwidth at -1.0 dB

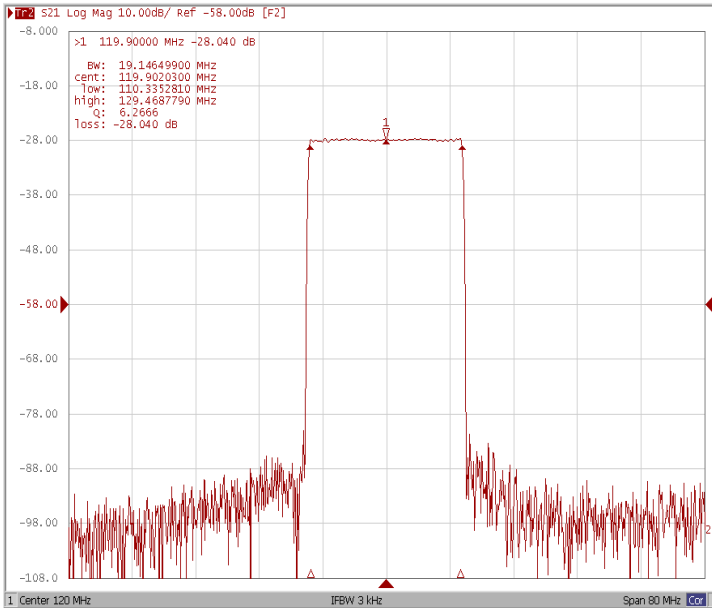

#### Bandwidth at -3.0 dB

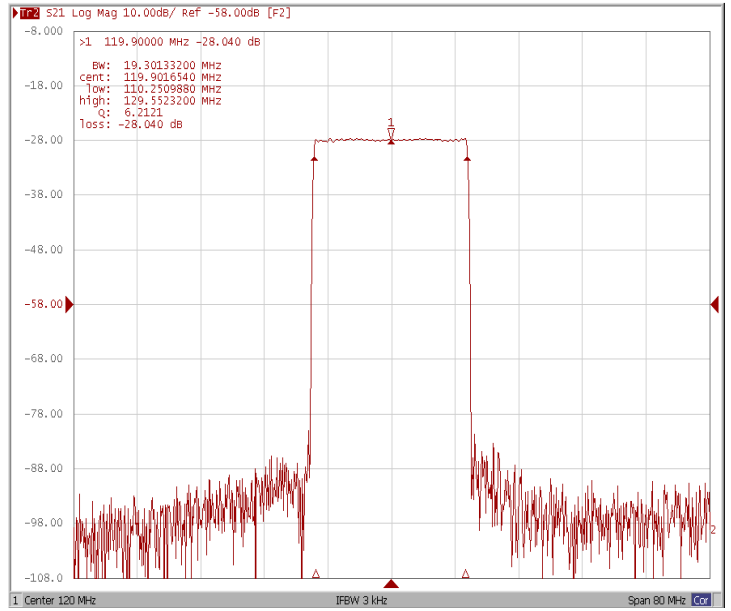

#### Bandwidth at -40.0 dB

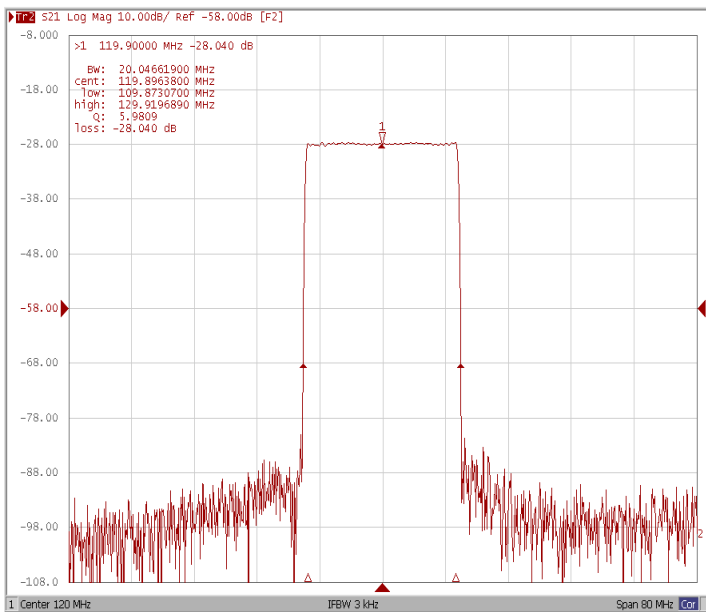

#### Relative Attenuation (Fo +/-10MHz)

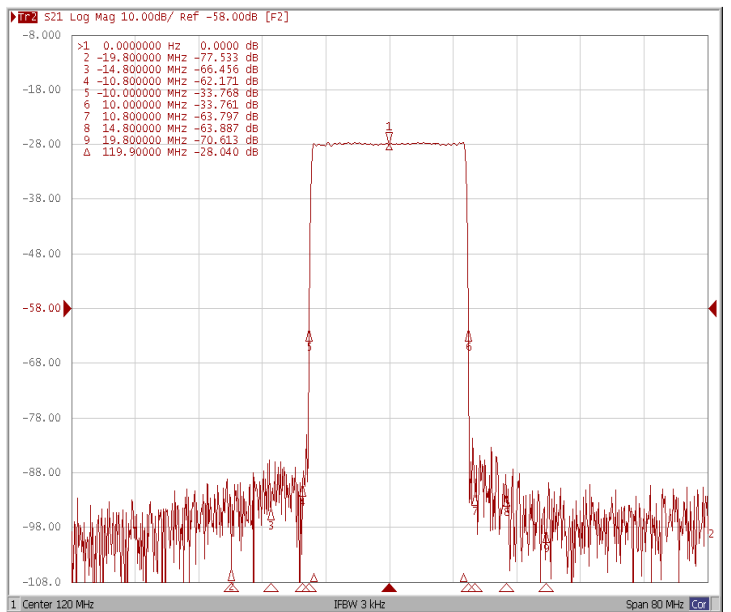



### Ripple Variation Fo±9.42MHz

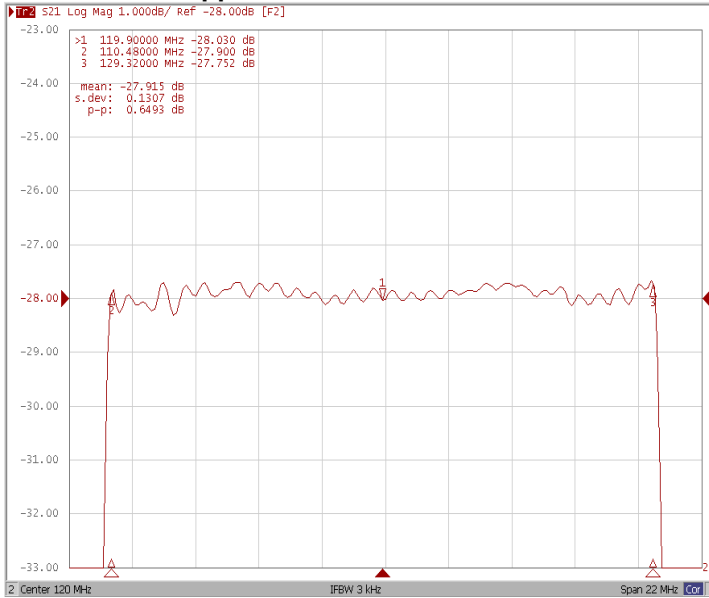

### Group Delay Variation Fo±9.42MHz

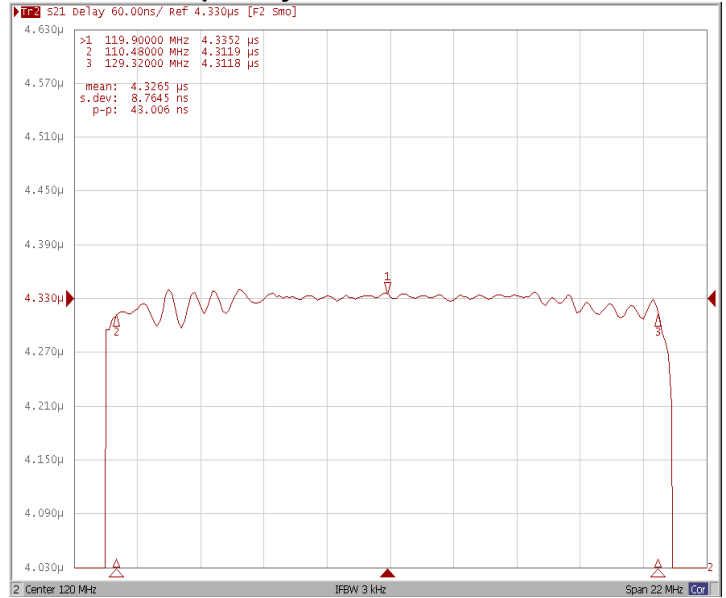

### Smith Chart

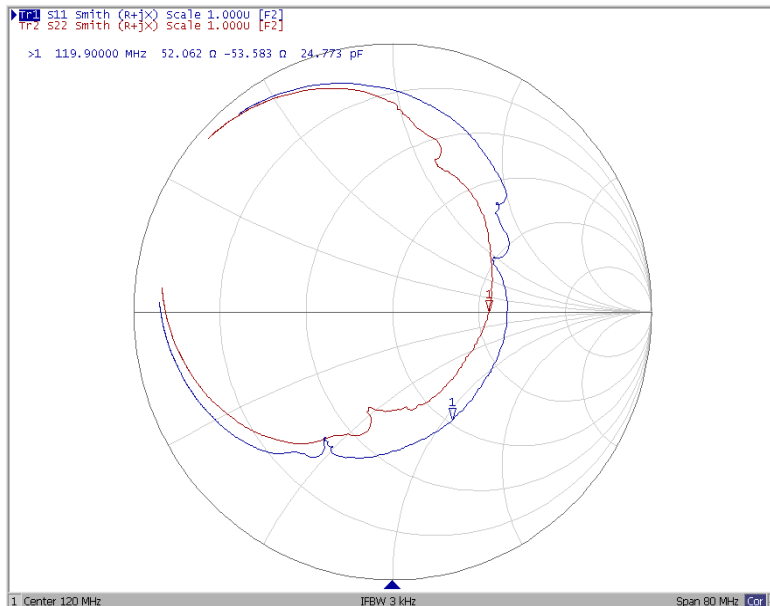



### VSWR

