

# Plug & Play Power

next generation power source

## Lowest Profile (1U) Highest Efficiency

### FEATURES

- up to 1200W multi-output power in 1U (40mm)
- 1.5V to 58V standard output voltages
- All outputs fully floating
- Plug & Play power module architecture
  - allows fast custom configurations
  - facilitates rapid prototyping
  - simplifies logistics
- Ultra-high efficiency up to 90%
- Series / Parallel of multiple outputs
- Visual LED indicators

### APPLICATIONS INCLUDE

- Industrial machines
- Test and measurement
- Automation equipment
- Telecommunications
- Medical equipment
- Laboratory and Diagnostic equipment
- Audio and broadcast
- Linear and rotary motion
- 19" systems



Excelsys brings over 20 years experience of modular power supply development and applications together with the most modern product development and design techniques in the revolutionary Xgen series.

The Xgen series brings OEM power supplies to a new paradigm, combining technical excellence with logistics simplicity to fully resolve all the concerns regularly expressed by users of multiple-output power supplies. Xgen continues the Excelsys tradition of providing an instant, no compromise power solution for any application where a unique set of voltage and current requirements is needed.

**Too much heat generated in your OEM equipment?  
Difficult to maintain your equipment at the right temperature?**

**EFFICIENCY** Xgen has industry-unrivalled efficiency, exceeding 90% !! This means that less than half of the amount of waste heat is created in comparison to conventional multiple output power sources with efficiencies of 80% and lower. It also guarantees increased reliability.

Now, that's a **cool** power supply!

**Not enough space available in your OEM equipment?  
Is space at a premium, making design and manufacture difficult and compromised?**

**SPACE** Xgen has industry-unrivalled power density for a full functionality ac/dc power supply, at 15W/in<sup>3</sup>. Check it out! You can get 1200W of multiple-output power source in 1U rack space - Xgen dimension: 40.4mm! It's so compact, you'll hardly notice it, once installed, and it leaves plenty more space for your other components and general accessibility.

Now, that's a **discreet** power supply!

**Need a custom power supply in a hurry?**

**CUSTOM POWER** Xgen is a true Plug & Play multiple-output power supply. Any one of more than 30 million configurations can be assembled anywhere, in under 5 minutes, from standard, volume-produced modules. This is the new-paradigm: a custom power supply available in 5 minutes from standard parts.

Now, that's a **new paradigm** power supply!

**Worried about meeting all relevant standards - EMC, Safety, etc?**

**STANDARD APPROVALS** Xgen series models are fully compliant with all relevant standards. Xcite, Xlite, Xhite and Xqite models meet the requirements of EN60950, UL60950, CSA22.2, EN61000-3-x and EN61000-4-x. Additionally Xvite and Xmite models meet the requirements of EN60601-1 and UL2601 for medical applications.



Now, that's a **re-assuring** power supply!

**Looking for a cost-effective long term solution for all your power supply requirements?**

**COST-EFFECTIVE** Xgen is configured from standard component parts that are manufactured in volume in a world class manufacturing facility. This allows Excelsys to provide you with all the benefits of Xgen at a world class competitive price. Call Excelsys or one of our distributors and find out for yourself.

Now, that's an **excellent value** power supply!



## Excelsys Development and Design Methodology

Excelsys has applied the most modern and rigorous processes and design techniques to development of the Xgen product range.

A world-class Stage-Gate™ development process ensures that a holistic approach to development and design is guaranteed, with optimised outcomes built in from the start in respect of customer needs, manufacturing, support and logistics. The Stage-Gate™ process provides the framework for efficient and effective teamwork within Excelsys as well as between Excelsys and its design partners.

The development-specific processes are supplemented by the company-wide process requirements of ISO9001:2000, in particular in the ISO9001:2000 designated area of 'Product Realisation'.

Excelsys was an early adopter of and is fully approved to this latest, upgraded ISO9001:2000 standard.

As well as design laboratory testing, Excelsys has applied exhaustive HALT testing and field prototype testing to development of Xgen. Highly Accelerated Life Testing ensures that design margins are more than sufficient to provide insensitivity to manufacturing variability and to maximise field reliability.



**Voltage Adjustment - Local**

The multi-turn potentiometer that adjusts each output within the specified range may be accessed via the output panel of the power supply. Clockwise rotation increases output voltage. Resolution is approximately 5% of nominal voltage (Vnom) per turn.

**Voltage Adjustment - Remote (resistive / electronic)**

The output voltage may be adjusted or trimmed by means of an external resistor or potentiometer network connected to the Vtrim pin. Linear Electronic programming is also possible and may be implemented according to the formula  $V_{out} = K V_{control}$ . See Xgen series Designers' Manual for full details.

**Paralleling**

To achieve increased current capacity, simply parallel outputs using the standard parallel links. Excelsys 'wireless' sharing ensures that current hogging is not possible.

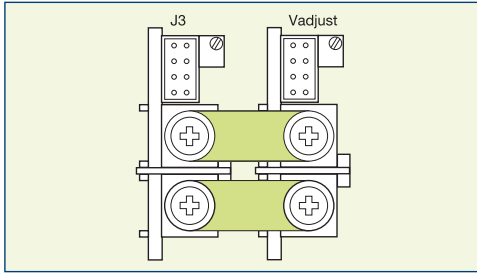

Standard parallel links can be supplied. To order, please use part number XP1.

**Seriesing**

To achieve increased output voltages, simply series outputs using standard series links, paying attention to the requirements to maintain SELV levels if required in your system.

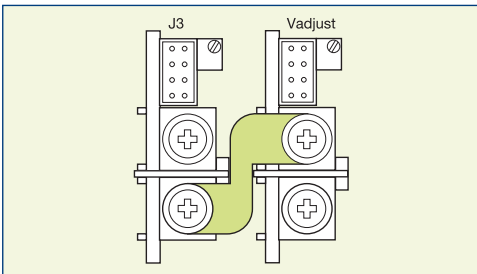

Standard serial links can be supplied. To order, please use part number XS1.

**Remote Sensing**

When the load is remote from the power supply, the remote sense pins may be used to compensate for drops in the power leads. Where the power cabling contributes significant dynamic impedance, see Xgen series Designers' Manual.

**Bias Voltage**

A SELV isolated 5V (always on) bias voltage rated at 250mA is provided on J2 to facilitate miscellaneous control functions.

**Current Limit Adjustment**

The output current limit setting may be adjusted (downwards only) by means of an external resistor connection to the I trim pin.

**Inhibit/Enable**

Inhibiting may be implemented either globally or on a per module basis (powerPac or powerMod inhibiting). Reverse logic (Enabling) may also be implemented, see Xgen series Designers' Manual.

**AC Fail**

Open collector signal indicating that the input voltage has failed or is less than 80Vac. This signal changes state giving 5mS of warning before loss of output regulation. See Xgen series Designers' Manual for full specifications.

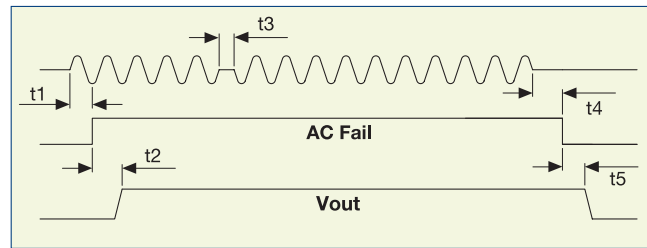

**Temperature Alarm (Option 01)**

Open collector signal indicating excessive powerPac temperatures due to fan failure or operation beyond ratings. This signal is activated at least 10ms prior to system shutdown.

**Fan Fail (Option 01)**

Open collector signal indicating that at least one of the system fans have failed. This does not cause system shutdown.

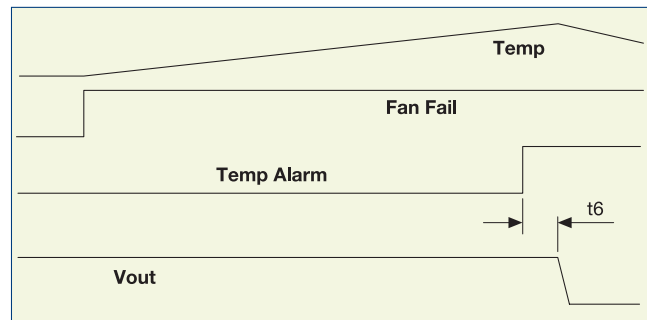

**Power Good**

Opto-isolated output signal indicates that the powerMod is operating correctly and output voltage is within normal band. Opto transistor ON = Good.

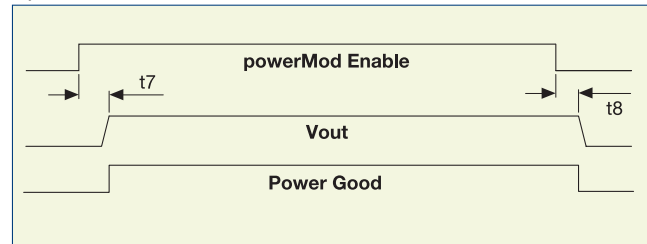

**Indication LEDs**

Each powerMod has a visual indicator to identify that it is operating within normal ratings. Very useful for system diagnosis.

**Signal Connector Pinout**

Pin	J2 (powerPac)	J3 (powerMod TYPE A)**	J3 (powerMod Type B)**
1	common	+sense	+pg (V2)
2	+5V bias	-sense	-pg (V2)
3		V trim	inhibit (V2)
4	ac fail	I trim	common (V2)
5	fan fail*	+inhibit/enable	+pg (V1)
6	global enable	-inhibit/enable	-pg (V1)
7	temp alarm*	+power good	inhibit (V1)
8	global inhibit	-power good	common (V1)

\*Option 01 only

\*\*See individual powerMod datasheets

The Xgen series power supplies combine feature-laden front-ends (**powerPacs**) with slide-in output converters (**powerMods**). The plug-together architecture facilitates 'instant' custom power solutions with industry leading 15W/in<sup>3</sup> power density and up to 90% conversion efficiency.

**powerPacs** (6slot package, 127mm wide)

Family	MODEL	Watts
Xcite	XCA	400W
	XCB	700W
	XCC	1000W
	XCD	1200W

The Xhite family is designed specifically for extended temperature applications fully specified from -20°C to +70°C with no derating !!!

The Xqite family is designed specifically for acoustic sensitive applications.

	Family	MODEL	Watts
Med	Xvite	XVA	400W
		XVB	700W
		XVC	1000W
		XVD	1200W
HT	Xhite	XHA	400W
		XHB	600W
QT	Xqite	XQA	400W
		XQB	900W

**powerPacs** (4slot package, 89mm wide)

Family	MODEL	Watts
Xlite	XLA	200W
	XLB	400W
	XLC	600W

	Family	MODEL	Watts
Med	Xmite	XMA	200W
		XMB	400W
		XMC	600W

**powerMods** (for use with all powerPac models)

MODEL	Vmin	Vnom	Vmax	Imax	Watts
Xg1	1.5	2.5	3.6	50A	125W
Xg2	3.2	5.0	6.0	40A	200W
Xg3	6.0	12.0	15.0	20A	240W
Xg4	12.0	24.0	30.0	10A	240W
Xg5	28.0	48.0	58.0	6A	288W
Xg7	5.0	24.0	28.0	5A	120W
Xg8	5.0	24.0	28.0	3A	72W
	5.0	24.0	28.0	3A	72W

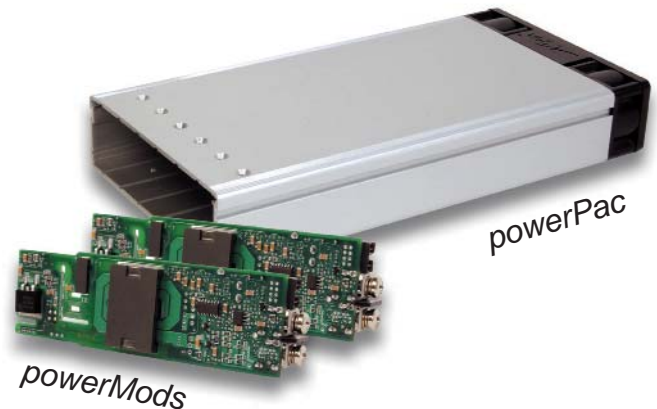

**HOW TO ORDER**

**Configured Units** may be specified and ordered using the part numbering system shown opposite. For example, part number XVC123400-01 specifies the following 1000W medical power supply.

- 2.5V @ 50A 5V @ 40A 12V @ 20A 24V @ 10A
- Thermal signals suite fitted to powerPac

**Accessories** may be ordered directly using the part numbers shown.

Part	Part No.	
Left Slot Cover	XB1	<i>Note that unused slots should be fitted with appropriate slot covers.</i>
Inner Slot Cover	XB2	
Right Slot Cover	XB3	
Series Link	XS1	
Parallel Link	XP1	

**powerPacs** may be ordered directly using the model number shown in the tables followed by the appropriate option code suffix. E.g. XVB-01 is the part number for 700W powerPac with medical approval and thermal signals.

**powerMods** may be ordered directly using the model numbers shown in the powerMod table. E.g. Xg2 is the part number for a 5V 40A module.

**powerKits** consist of application specific powerPacs and a selection of powerMods packaged in a convenient carry case. Particularly useful for systems designers. See powerKit datasheet.

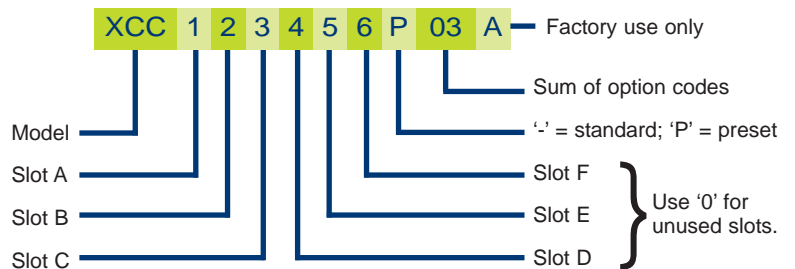

**Xgen Option Codes**

- 01 Thermal Signals
- 02 Reverse Fan (*not available on 1200W models*)

**Preset Units**

Units are shipped with nominal output voltages unless presetting is specified. Excelsys can preset units to your exact requirements, through use of appropriate parallel and series links and through voltage adjustment to specific preset levels. See [www.excelsys.com](http://www.excelsys.com) for more details.

**On-line Configuration and Ordering**

Now build your Xgen product on-line using our configuration wizard. Simply enter your Volts and Amps requirements and the wizard will do the rest.



**AC/DC Power Supply**  
Ultra-high efficiency 1U size



patents pending



Standard

**PLUG & PLAY POWER**  
next generation power source

**FEATURES**

- 1.5V to 58V standard output voltages
- All outputs fully floating
- Extra low profile: 1U height (40mm)
- Ultra high efficiency, up to 90%
- Plug & Play Power
  - allows fast custom configuration
  - allow easy logistics
- Reduced system heat dissipation
- Few electrolytic capacitors (all long life)
- Visual LED indicators
- Series / Parallel of multiple outputs
- 5V bias standby voltage provided
- Individual output control signals

**APPLICATIONS INCLUDE**

- Industrial machines
- Test and measurement
- Automation equipment
- Printing
- Telecommunications
- For Medical applications see Xvite

The Xcite family of power supplies provides up to an incredible 1200W in an extremely compact 1U x 260 x 127mm package. Boasting industry leading power density of 15W/in<sup>3</sup> and efficiencies of up to 90%, the Xcite family employs an innovative plug & play architecture that allows users to instantly configure a custom power solution in less than 5 minutes!

Ultra high efficiencies and high power density are made possible through the combination of low loss technologies and the best field-proven technologies in planar magnetics and surface mount electronics. Significantly increased efficiency reduces system thermal load by more than 50%.

The Xcite family consists of 4 *powerPac* models ranging in power levels from 400W to 1200W. Each model may be populated with up to 6 *powerMods* selected from the table of *powerMods* shown below.

All configurations carry full safety agency approvals, UL60950, EN60950 and are CE marked. For alternative power interfaces contact [support@excelsys.com](mailto:support@excelsys.com)

**powerMods**

MODEL	Vmin	Vnom	Vmax	I <sub>max</sub>	Watts*	
Xg1	1.5	2.5	3.6	50A	125W	
Xg2	3.2	5.0	6.0	40A	200W	
Xg3	6.0	12.0	15.0	20A	240W	
Xg4	12.0	24.0	30.0	10A	240W	
Xg5	28.0	48.0	58.0	6A	288W	
Xg7	5.0	24.0	28.0	5A	120W	
Xg8	v1	5.0	24.0	28.0	3A	72W
	v2	5.0	24.0	28.0	3A	72W

**powerPacs**

	MODEL	Watts
Xcite	XCA	400W
	XCB	700W
	XCC	1000W
	XCD	1200W

\*see datasheet *powerMods* for full output module specifications  
*powerMod* ratings when used with Xcite *powerPac*

**EFFICIENCY (typical)**

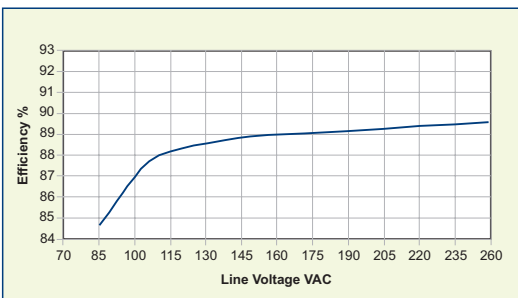

**MECHANICAL SPECIFICATIONS**

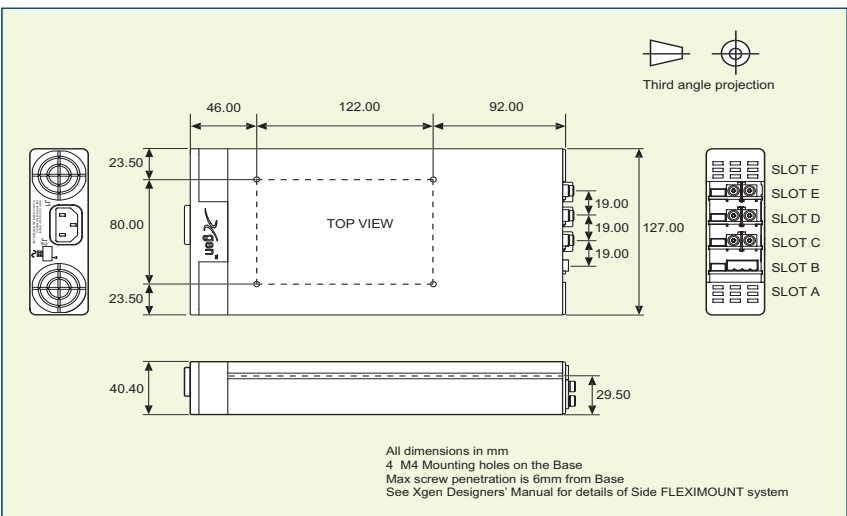

1

**SPECIFICATION** applies to configured units consisting of **powerMods** modules plugged into the appropriate **powerPac**

Standard

INPUT					
Parameter	Conditions/Description	Min	Nom	Max	Units
Input Voltage Range	Universal Input	85		264	VAC
		120		380	VDC
Input Frequency Range		47		63	Hz
Power Rating	XCA			400	W
	XCB			700	W
	XCC	Derate linearly from 1000W at 100VAC to 850W at 85VAC		1000	W
	XCD	Derate linearly from 1200W at 120VAC to 850W at 85VAC		1200	W
Input Current	XCA	85VAC in 400W out	7.5		A
	XCB	85VAC in 700W out	9.5		A
	XCC, XCD	85VAC in 850W out	11.5		A
Inrush Current	230VAC @ 25°C			20	A
Undervoltage Lockout	Shutdown	70		78	VAC
Fusing	XCA	250V		F8A HRC	
	XCB	250V		F10A HRC	
	XCC, XCD	250V		F12A HRC	

OUTPUT					
Parameter	Conditions/Description	Min	Nom	Max	Units
powerMod Power	As per powerMod table				
Output Adjustment Range	Manual: Multi-turn potentiometer. As per powerMod table				
	Electronic: See Xgen Designers' Manual				
Minimum Load			0		A
Line Regulation	For ±10% change from nominal line			±0.1	%
Load & Cross Regulation	For 25% to 75% load change			±0.2	%
Transient Response	For 25% to 75% load change	Voltage Deviation		10	%
			Settling Time		250
Ripple and Noise	20MHz Bandwidth			1.0	% pk-pk
Overvoltage Protection	1st level: Vset Tracking. 2nd level: Vmax (Latching)	110		125	%
Overcurrent Protection	Straight line with hiccup activation at <30% of Vnom See powerMod datasheet and Designer's Manual for full details	110		120	%
Remote Sense	Max. line drop compensation. (except Xg7, Xg8)			0.5	VDC
Overshoot				2	%
Turn-on Delay	From AC In / Enable signal			300 / 30	ms
Rise Time	Monotonic			5	ms
Hold-up Time	For nominal output voltages at full load. XCA,XCB,XCC / XCD	20 / 15			ms
Output Isolation	Output to Output / Output to Chassis	500 / 500			VDC

GENERAL					
Parameter	Conditions/Description	Min	Nom	Max	Units
Isolation Voltage	Input to Output	3000			VAC
	Input to Chassis	1500			VAC
Efficiency	230VAC, 1200W @ 24V		90		%
Safety Agency Approvals	EN60950, UL60950, CSA22.2 No.950 UL File No. E181875				
Leakage Current	250VAC, 60Hz, 25°C			1.5	mA
Signals	See Xgen Series datasheet				
Bias Supply	Always ON. Current 250mA	4.9	5.0	5.1	VDC
Reliability	Failures per million hours at 25°C and full load			1.0	fpmh
	See Designers' Manual. powerPac excludes fans			0.6	fpmh

EMC					
Parameter	Standard		Level		Units
<b>Emissions</b>					
Conducted	EN55011, EN55022, FCC		Level B		
Radiated	EN55011, EN55022, FCC		Level B		
Harmonic Distortion	EN61000-3-2		Compliant		
Flicker and Fluctuation	EN61000-3-3		Compliant		
<b>Immunity</b>					
Electrostatic Discharge	EN61000-4-2		Level 4		
Radiated RFI	EN61000-4-3		Level 3		
Fast Transients - burst	EN61000-4-4		Level 4		
Input Line Surges	EN61000-4-5		Class 4		
Conducted RFI	EN61000-4-6		10		V/m
Voltage Dips	EN61000-4-11 (EN55024)		10		ms

ENVIRONMENTAL					
Parameter	Conditions/Description	Min	Nom	Max	Units
Operating Temperature	Full Load up to 50°C. See derating below.	-20		+70	°C
Storage Temperature		-40		+85	°C
Derating	2.5% per °C above 50°C				
Relative Humidity	Non-condensing	5		95	%RH
Shock	3000 Bumps, 10G (16ms) half sine				
Vibration	1.5G	10		200	Hz

- NOTES**
- This product is not intended for use as a stand alone unit and must be installed by qualified personnel.
  - The specifications contained herein are believed to be correct at time of publication and are subject to change without notice.
  - All specifications at nominal input, full load, 25°C unless otherwise stated.

Doc. 40032 rev. 02 04/05



**Europe/Asia**  
 Excelsys Technologies Ltd t: +353 1 8900933  
 Swords Business Park f: +353 1 8901358  
 Swords, Co. Dublin e: sales@excelsys.com  
 IRELAND

**North America**  
 Excelsys Technologies t: (972) 771 4544  
 519 Interstate 30, #309 f: (972) 421 1805  
 Rockwall, TX 75087 e: salesusa@excelsys.com  
 USA



## Slimline Power Supply

User Configurable 1U size



patents pending



Slimline

### PLUG & PLAY POWER next generation power source

#### FEATURES

- Slimmest 400W configurable power
- Extra low profile: 1U height (40mm)
- All outputs fully floating
- Ultra high efficiency, up to 89%
- Plug & Play Power
  - allows fast custom configuration
  - allow easy logistics
- FLEXIMOUNT Flexible mounting system
- Few electrolytic capacitors (all long life)
- Visual LED indicators
- Series / Parallel of multiple outputs
- 5V bias standby voltage provided
- Individual output control signals

#### APPLICATIONS INCLUDE

- Industrial machines
- Test and measurement
- Automation equipment
- Printing
- Telecommunications
- For Medical applications see Xmite

The Xlite family of power supplies provides up to 600W in a slimline 1U x 260 x 89mm package. Providing up to 8 isolated outputs, the Xlite family is the most flexible power supply in its class and brings affordable configurable power to the 200-600W market.

The slimline product boasts unrivalled power density saving valuable system space. Combine with ultra high efficiencies, the Xlite family provides system designers with flexible instant solutions that significantly shorten and simplify system design-in time.

The Xlite family consists of 3 *powerPac* models in 200W, 400W and 600W power levels. Each *powerPac* model may be populated with up to 4 *powerMods* selected from the table of *powerMods* shown below.

All configurations carry full safety agency approvals, UL60950, EN60950 and are CE marked. For alternative power interfaces contact [support@excelsys.com](mailto:support@excelsys.com)

#### powerMods

MODEL	Vmin	Vnom	Vmax	Imax	Watts*	
Xg1	1.5	2.5	3.6	50A	125W	
Xg2	3.2	5.0	6.0	40A	200W	
Xg3	6.0	12.0	15.0	20A	240W	
Xg4	12.0	24.0	30.0	10A	240W	
Xg5	28.0	48.0	58.0	6A	288W	
Xg7	5.0	24.0	28.0	5A	120W	
Xg8	v1	5.0	24.0	28.0	3A	72W
	v2	5.0	24.0	28.0	3A	72W

#### powerPacs

	MODEL	Watts
Xlite	XLA	200W
	XLB	400W
	XLC	600W

\*see datasheet *powerMods* for full output module specifications  
*powerMod* ratings when used with Xlite *powerPac*

#### EFFICIENCY (typical)

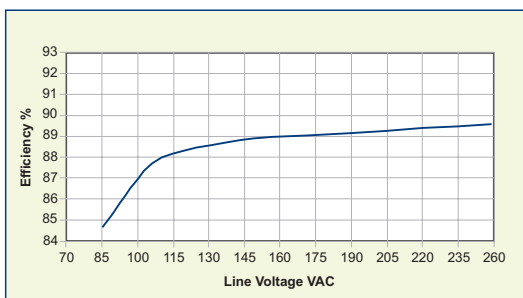

#### MECHANICAL SPECIFICATIONS

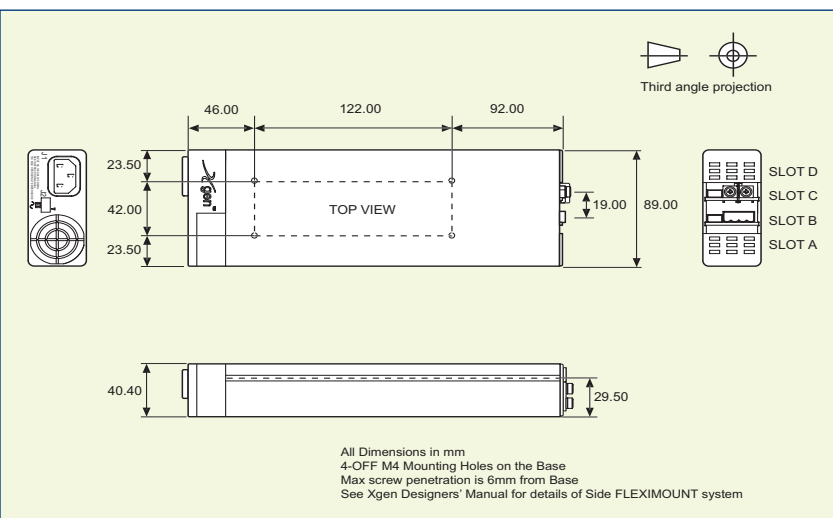

**SPECIFICATION** applies to configured units consisting of **powerMods** modules plugged into the appropriate **powerPac**

Slimline

INPUT					
Parameter	Conditions/Description	Min	Nom	Max	Units
Input Voltage Range	Universal Input	85		264	VAC
		120		380	VDC
Input Frequency Range		47		63	Hz
Power Rating	XLA			200	W
	XLB			400	W
	XLC			600	W
Input Current	XLA	85VAC in 200W out	4.0		A
	XLB	85VAC in 400W out	7.5		A
	XLC	85VAC in 400W out	7.5		A
Inrush Current	230VAC @ 25°C			20	A
Undervoltage Lockout	Shutdown	70		78	VAC
Fusing	XLA	250V 5 x 20mm		F5A HRC	
	XLB	250V 5 x 20mm		F8A HRC	
	XLC	250V 5 x 20mm		F8A HRC	
OUTPUT					
Parameter	Conditions/Description	Min	Nom	Max	Units
<b>powerMod Power</b>	As per <i>powerMod</i> table				
Output Adjustment Range	Manual: Multi-turn potentiometer. As per <i>powerMod</i> table Electronic: See Xgen Designers' Manual				
Minimum Load			0		A
Line Regulation	For ±10% change from nominal line			±0.1	%
Load Regulation	For 25% to 75% load change			±0.2	%
Cross Regulation				±0.2	%
Transient Response	For 25% to 75% load change	Voltage Deviation		10	%
		Settling Time		250	µs
Ripple and Noise	20MHz Bandwidth			1.0	% pk-pk
Overvoltage Protection	Two-level. 1st level: Vset Tracking. 2nd level: Vmax (Latching)	110		125	%
Overcurrent Protection	Straight line with hiccup activation at <30% of Vnom See <i>powerMod</i> datasheet and Designer's Manual for full details	110		120	%
Remote Sense	Max. line drop compensation. (except Xg7, Xg8)			0.5	VDC
Overshoot				2	%
Turn-on Delay	From AC In / Enable signal			300 / 30	ms
Rise Time	Monotonic			5	ms
Hold-up Time	For nominal output voltages at full load	20			ms
Output Isolation	Output to Output / Output to Chassis	500 / 500			VDC
GENERAL					
Parameter	Conditions/Description	Min	Nom	Max	Units
Isolation Voltage	Input to Output Input to Chassis	3000			VAC
		1500			VAC
Efficiency	230VAC, 400W @ 24V		89		%
Safety Agency Approvals	EN60950, UL60950, CSA22.2 No.950 UL File No. E181875				
Leakage Current	250VAC, 60Hz, 25°C			1.5	mA
Signals	See Xgen Series datasheet				
Bias Supply	Always ON. Current 250mA	4.9	5.0	5.1	VDC
Reliability	Failures per million hours at 25°C and full load See Designers' Manual. <i>powerPac</i> excludes fans	<i>powerMod</i>		1.0	fpmh
		<i>powerPac</i>		0.5	fpmh
EMC					
Parameter	Standard	Level		Units	
<b>Emissions</b>					
Conducted	EN55011, EN55022, FCC	Level B			
Radiated	EN55011, EN55022, FCC	Level B			
Harmonic Distortion	EN61000-3-2	Compliant			
Flicker and Fluctuation	EN61000-3-3	Compliant			
<b>Immunity</b>					
Electrostatic Discharge	EN61000-4-2	Level 4			
Radiated RFI	EN61000-4-3	Level 3			
Fast Transients - burst	EN61000-4-4	Level 4			
Input Line Surges	EN61000-4-5	Class 4			
Conducted RFI	EN61000-4-6	10		V/m	
Voltage Dips	EN61000-4-11 (EN55024)	10		ms	
ENVIRONMENTAL					
Parameter	Conditions/Description	Min	Nom	Max	Units
Operating Temperature	Full Load up to 50°C. See derating below.	-20		+70	°C
Storage Temperature		-40		+85	°C
Derating	2.5% per °C above 50°C				
Relative Humidity	Non-condensing	5		95	%RH
Shock	3000 Bumps, 10G (16ms) half sine				
Vibration	1.5G	10		200	Hz

- NOTES**
1. This product is not intended for use as a stand alone unit and must be installed by qualified personnel.
  2. The specifications contained herein are believed to be correct at time of publication and are subject to change without notice.
  3. All specifications at nominal input, full load, 25°C unless otherwise stated.

Doc. 40038 rev.01 04/05



**Europe/Asia**  
 Excelsys Technologies Ltd t: +353 1 8900933  
 Swords Business Park f: +353 1 8901358  
 Swords, Co. Dublin e: sales@excelsys.com  
 IRELAND

**North America**  
 Excelsys Technologies t: (972) 771 4544  
 519 Interstate 30, #309 f: (972) 421 1805  
 Rockwall, TX 75087 e: salesusa@excelsys.com  
 USA





patents pending



Medical

**Medically Approved**  
Ultra-high efficiency 1U size

**PLUG & PLAY POWER**  
next generation power source

**FEATURES**

- UL2601-1 and EN60601-1 approved
- Less than 300µA leakage current
- 4000VAC isolation
- Extra low profile: 1U height (40mm)
- Ultra high efficiency up to 90%
- Plug & Play Power
  - allows fast custom configuration
  - allow easy logistics
- Reduced system heat dissipation
- Few electrolytic capacitors (all long life)
- Visual LED indicators
- Series / Parallel of multiple outputs
- 5V bias standby voltage provided
- Individual output control signals

**APPLICATIONS INCLUDE**

- Clinical diagnostic equipment
- Medical lasers
- Dialysis equipment
- For Standard applications see Xcite

The Xvite family of medically approved power supplies provides up to an incredible 1200W in an extremely compact 1U x 260 x 127mm package. Providing up to 12 isolated DC outputs, the Xvite family employs innovative plug & play architecture allowing users to instantly configure a custom power solution in less than 5 minutes!

The Xvite family consists of 4 powerPacs ranging in power levels from 400W to 1200W and 7 powerMod DC output modules. Simply select the appropriate powerPac and up to 6 powerMods from the tables below to complete your custom power supply.

The Xvite family boasts an industry leading power density of 15W/in<sup>3</sup> and ultra-high efficiencies (up to 90%). The significant system space savings and reduced heat dissipation radically simplify system design.

All configurations carry full safety agency approvals including UL2601-1 and EN60601-1 and are CE marked. For alternative power interfaces contact [support@excelsys.com](mailto:support@excelsys.com)

**powerMods**

MODEL	Vmin	Vnom	Vmax	Imax	Watts*	
Xg1	1.5	2.5	3.6	50A	125W	
Xg2	3.2	5.0	6.0	40A	200W	
Xg3	6.0	12.0	15.0	20A	240W	
Xg4	12.0	24.0	30.0	10A	240W	
Xg5	28.0	48.0	58.0	6A	288W	
Xg7	5.0	24.0	28.0	5A	120W	
Xg8	v1	5.0	24.0	28.0	3A	72W
	v2	5.0	24.0	28.0	3A	72W

**powerPacs**

	MODEL	Watts
Xvite	XVA	400W
	XVB	700W
	XVC	1000W
	XVD	1200W

\*see datasheet powerMods for full output module specifications  
powerMod ratings when used with Xvite powerPac

**EFFICIENCY (typical)**

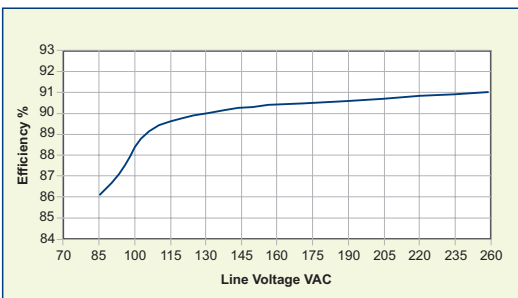

**MECHANICAL SPECIFICATIONS**

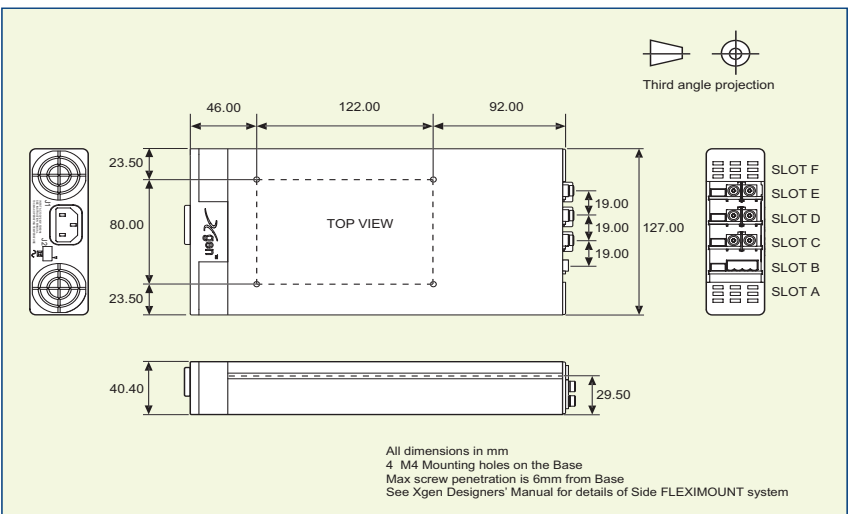

**SPECIFICATION** applies to configured units consisting of **powerMods** modules plugged into the appropriate **powerPac**

Medical

INPUT					
Parameter	Conditions/Description	Min	Nom	Max	Units
Input Voltage Range	Universal Input	85		264	VAC
		120		380	VDC
Input Frequency Range		47		63	Hz
Power Rating	XVA			400	W
	XVB			700	W
	XVC	Derate linearly from 1000W at 100VAC to 850W at 85VAC		1000	W
	XVD	Derate linearly from 1200W at 120VAC to 850W at 85VAC		1200	W
Input Current	XVA	85VAC in 400W out	7.5		A
	XVB	85VAC in 700W out	9.5		A
	XVC, XVD	85VAC in 850W out	11.5		A
Inrush Current	230VAC @ 25°C			20	A
Undervoltage Lockout	Shutdown	70		78	VAC
Fusing	XVA	250V		F8A HRC	
	XVB	250V		F10A HRC	
	XVC, XVD	250V		F12A HRC	

OUTPUT					
Parameter	Conditions/Description	Min	Nom	Max	Units
powerMod Power	As per powerMod table				
Output Adjustment Range	Manual: Multi-turn potentiometer. As per powerMod table				
	Electronic: See Xgen Designers' Manual				
Minimum Load			0		A
Line Regulation	For ±10% change from nominal line			±0.1	%
Load & Cross Regulation	For 25% to 75% load change			±0.2	%
Transient Response	For 25% to 75% load change	Voltage Deviation		10	%
				Settling Time	250
Ripple and Noise	20MHz Bandwidth			1.0	% pk-pk
Overvoltage Protection	Two-level. 1st level: Vset Tracking. 2nd level: Vmax (Latching)	110		125	%
Overcurrent Protection	Straight line with hiccup activation at <30% of Vnom See powerMod datasheet and Designer's Manual for full details	110		120	%
Remote Sense	Max. line drop compensation. (except Xg7, Xg8)			0.5	VDC
Overshoot				2	%
Turn-on Delay	From AC In / Enable signal			300 / 30	ms
Rise Time	Monotonic			5	ms
Hold-up Time	For nominal output voltages at full load. XCA,XCB,XCC / XCD	20 / 15			ms
Output Isolation	Output to Output / Output to Chassis	500 / 500			VDC

GENERAL					
Parameter	Conditions/Description	Min	Nom	Max	Units
Isolation Voltage	Input to Output	4000			VAC
	Input to Chassis	1500			VAC
Efficiency	230VAC, 1200W @ 24V		90		%
Safety Agency Approvals	EN60601-1, UL2601-1, CSA601-1 UL File No. E230761				
Earth Leakage Current	250VAC, 60Hz, 25°C			300	µA
Signals	See Xgen Series datasheet				
Bias Supply	Always ON. Current 250mA	4.9	5.0	5.1	VDC
Reliability	Failures per million hours at 25°C and full load			1.0	fpmh
	See Designers' Manual. powerPac excludes fans			0.6	fpmh

EMC					
Parameter	Standard		Level		Units
<b>Emissions</b>					
Conducted	EN55011, EN55022, FCC		Level B		
Radiated	EN55011, EN55022, FCC		Level B		
Harmonic Distortion	EN61000-3-2		Compliant		
Flicker and Fluctuation	EN61000-3-3		Compliant		
<b>Immunity</b>					
Electrostatic Discharge	EN61000-4-2		Level 4		
Radiated RFI	EN61000-4-3		Level 3		
Fast Transients - burst	EN61000-4-4		Level 4		
Input Line Surges	EN61000-4-5		Class 4		
Conducted RFI	EN61000-4-6		10		V/m
Voltage Dips	EN61000-4-11 (EN55024)		10		ms

ENVIRONMENTAL					
Parameter	Conditions/Description	Min	Nom	Max	Units
Operating Temperature	Full Load up to 50%. See derating below	-20		+70	°C
Storage Temperature		-40		+85	°C
Derating	2.5% per °C above 50°C				
Relative Humidity	Non-condensing	5		95	%RH
Shock	3000 Bumps, 10G (16ms) half sine				
Vibration	1.5G	10		200	Hz

- NOTES**
- This product is not intended for use as a stand alone unit and must be installed by qualified personnel.
  - The specifications contained herein are believed to be correct at time of publication and are subject to change without notice.
  - All specifications at nominal input, full load, 25°C unless otherwise stated.

Doc. 40039 rev. 02 04/05



**Europe/Asia**  
 Excelsys Technologies Ltd t: +353 1 8900933  
 Swords Business Park f: +353 1 8901358  
 Swords, Co. Dublin e: sales@excelsys.com  
 IRELAND

**North America**  
 Excelsys Technologies t: (972) 771 4544  
 519 Interstate 30, #309 f: (972) 421 1805  
 Rockwall, TX 75087 e: salesusa@excelsys.com  
 USA



# Medical Power Supply

User Configurable 1U size

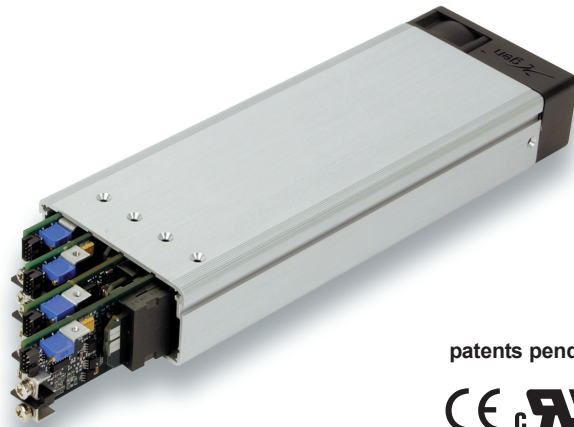

patents pending



## PLUG & PLAY POWER

next generation power source

### FEATURES

- EN60601-1 and UL2601-1 approved
- Less than 300µA leakage current
- 4000VAC isolation
- Slimmest 600W configurable power
- Extra low profile: 1U height (40mm)
- Ultra high efficiency, up to 89%
- Plug & Play Power
  - allows fast custom configuration
  - allow easy logistics
- FLEXIMOUNT Flexible mounting system
- Few electrolytic capacitors (all long life)
- Series / Parallel of multiple outputs
- 5V bias standby voltage provided
- Individual output control signals

### APPLICATIONS INCLUDE

- Radiological imaging
- Clinical diagnostics
- Medical lasers
- Clinical chemistry
- For non-medical applications see Xlite

The Xmite family of medically approved power supplies provides up to 600W in a slimline 1U x 260 x 89mm package. The Xmite family carries full safety agency approvals to EN60601-1 and UL2601-1, meeting the stringent creepage requirements in this compact package. Providing up to 8 isolated outputs, the Xmite family is the most flexible power supply in its class and brings affordable configurable power to the 200-600W medical market.

The Xmite family consists of 3 *powerPac* models in 200W, 400W and 600W power levels. Each *powerPac* model may be populated with up to 4 *powerMods* selected from the table of *powerMods* shown below. Simply select your appropriate *powerPac* and *powerMods* to get your instant custom power solution.

This slimline product boasts unrivalled power density, providing significant system space savings. Combined with ultra-high efficiencies, the Xmite family provides system designers with flexible instant solutions that significantly shorten system design-in time. For alternative power interfaces contact [support@excelsys.com](mailto:support@excelsys.com)

### powerMods

MODEL	Vmin	Vnom	Vmax	Imax	Watts*	
Xg1	1.5	2.5	3.6	50A	125W	
Xg2	3.2	5.0	6.0	40A	200W	
Xg3	6.0	12.0	15.0	20A	240W	
Xg4	12.0	24.0	30.0	10A	240W	
Xg5	28.0	48.0	58.0	6A	288W	
Xg7	5.0	24.0	28.0	5A	120W	
Xg8	v1	5.0	24.0	28.0	3A	72W
	v2	5.0	24.0	28.0	3A	72W

### powerPacs

	MODEL	Watts
Xmite	XMA	200W
	XMB	400W
	XMC	600W

\*see datasheet *powerMods* for full output module specifications  
*powerMod* ratings when used with Xmite *powerPac*

### EFFICIENCY (typical)

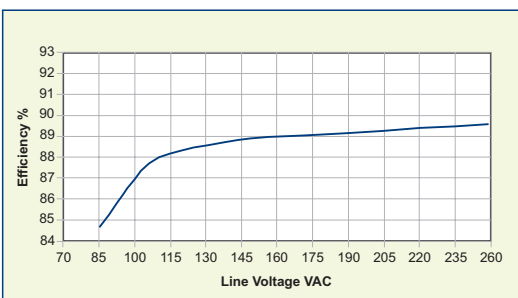

### MECHANICAL SPECIFICATIONS

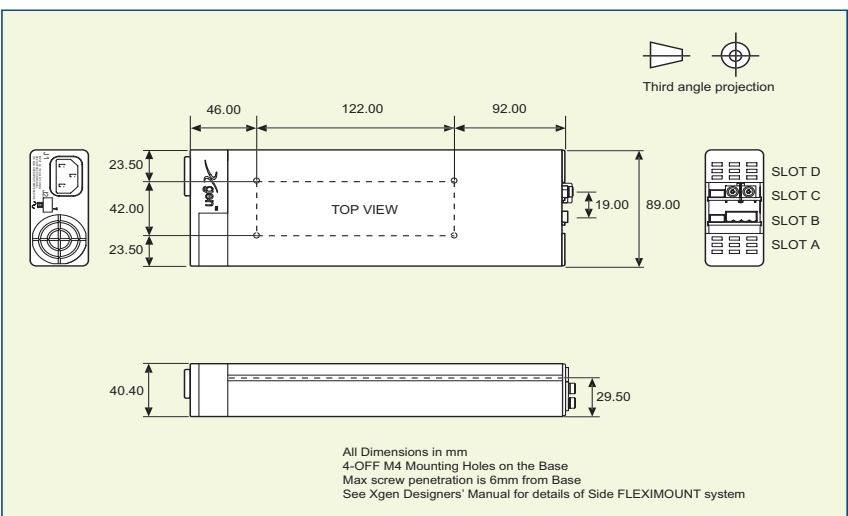

**SPECIFICATION** applies to configured units consisting of *powerMods* modules plugged into the appropriate *powerPac*

Slimline

INPUT					
Parameter	Conditions/Description	Min	Nom	Max	Units
Input Voltage Range	Universal Input	85		264	VAC
		120		380	VDC
Input Frequency Range		47		63	Hz
Power Rating	XMA			200	W
	XMB			400	W
	XMC			600	W
Input Current	XMA	85VAC in 200W out	4.0		A
	XMB	85VAC in 400W out	7.5		A
	XMC	85VAC in 400W out	7.5		A
Inrush Current	230VAC @ 25°C			20	A
Undervoltage Lockout	Shutdown	70		78	VAC
Fusing	XMA	250V 5 x 20mm		F5A HRC	
	XMB	250V 5 x 20mm		F8A HRC	
	XMC	250V 5 x 20mm		F8A HRC	

OUTPUT					
Parameter	Conditions/Description	Min	Nom	Max	Units
<i>powerMod</i> Power	As per <i>powerMod</i> table				
Output Adjustment Range	Manual: Multi-turn potentiometer. As per <i>powerMod</i> table Electronic: See Xgen Designers' Manual				
Minimum Load			0		A
Line Regulation	For ±10% change from nominal line			±0.1	%
Load Regulation	For 25% to 75% load change			±0.2	%
Cross Regulation				±0.2	%
Transient Response	For 25% to 75% load change	Voltage Deviation		10	%
		Settling Time		250	µs
Ripple and Noise	20MHz Bandwidth			1.0	% pk-pk
Overvoltage Protection	1st level: Vset Tracking. 2nd level: Vmax (Latching)	110		125	%
Overcurrent Protection	Straight line with hiccup activation at <30% of Vnom See <i>powerMod</i> datasheet and Designer's Manual for full details	110		120	%
Remote Sense	Max. line drop compensation. (except Xg7, Xg8)			0.5	VDC
Overshoot				2	%
Turn-on Delay	From AC In / Enable signal			300 / 30	ms
Rise Time	Monotonic			5	ms
Hold-up Time	For nominal output voltages at full load	20			ms
Output Isolation	Output to Output / Output to Chassis	500 / 500			VDC

GENERAL					
Parameter	Conditions/Description	Min	Nom	Max	Units
Isolation Voltage	Input to Output	4000			VAC
	Input to Chassis	1500			VAC
Efficiency	230VAC, 400W @ 24V		89		%
Safety Agency Approvals	EN60601-1, UL2601-1, CSA601-1 UL File No. E230761				
Leakage Current	250VAC, 60Hz, 25°C			300	µA
Signals	See Xgen Series datasheet				
Bias Supply	Always ON. Current 250mA	4.9	5.0	5.1	VDC
Reliability	Failures per million hours at 25°C and full load See Designers' Manual. <i>powerPac</i> excludes fans	<i>powerMod</i>		1.0	fpmh
		<i>powerPac</i>		0.5	fpmh

EMC					
Parameter	Standard	Level		Units	
<b>Emissions</b>					
Conducted	EN55011, EN55022, FCC	Level B			
Radiated	EN55011, EN55022, FCC	Level B			
Harmonic Distortion	EN61000-3-2	Compliant			
Flicker and Fluctuation	EN61000-3-3	Compliant			
<b>Immunity</b>					
Electrostatic Discharge	EN61000-4-2	Level 4			
Radiated RFI	EN61000-4-3	Level 3			
Fast Transients - burst	EN61000-4-4	Level 4			
Input Line Surges	EN61000-4-5	Class 4			
Conducted RFI	EN61000-4-6	10		V/m	
Voltage Dips	EN61000-4-11 (EN55024)	10		ms	

ENVIRONMENTAL					
Parameter	Conditions/Description	Min	Nom	Max	Units
Operating Temperature	Full Load up to 50°C See derating below	-20		+70	°C
Storage Temperature		-40		+85	°C
Derating	2.5% per °C above 50°C				
Relative Humidity	Non-condensing	5		95	%RH
Shock	3000 Bumps, 10G (16ms) half sine				
Vibration	1.5G	10		200	Hz

- NOTES**
- This product is not intended for use as a stand alone unit and must be installed by qualified personnel.
  - The specifications contained herein are believed to be correct at time of publication and are subject to change without notice.
  - All specifications at nominal input, full load, 25°C unless otherwise stated.

Doc. 40040 rev.02 04/05



**Europe/Asia**  
 Excelsys Technologies Ltd t: +353 1 8900933  
 Swords Business Park f: +353 1 8901358  
 Swords, Co. Dublin e: sales@excelsys.com  
 IRELAND

**North America**  
 Excelsys Technologies t: (972) 771 4544  
 519 Interstate 30, #309 f: (972) 421 1805  
 Rockwall, TX 75087 e: salesusa@excelsys.com  
 USA

# Xgen Series powerKit

**Ultimate in Plug & Play Power**  
your dreams come true!



## PLUG & PLAY POWER next generation power source

### FEATURES

- Make your own custom power supply!
- 1.5V to 58V standard output voltages
- Only available from Excelsys
- Straight line or Foldback current limit
- Output inhibit/enable control
- Parallel powerMods for higher current
- Series powerMods for higher voltages
- Available in application specific kits

### EACH powerKit CONTAINS

- One powerPac
- Seven powerMod dc output modules
- Xgen Designers' Manual
- Two pairs of parallel links (XP1)
- Two series links (XS1)
- Power & Signal mating connectors
- Quality posi screwdriver
- Quality Voltage adjustment tool

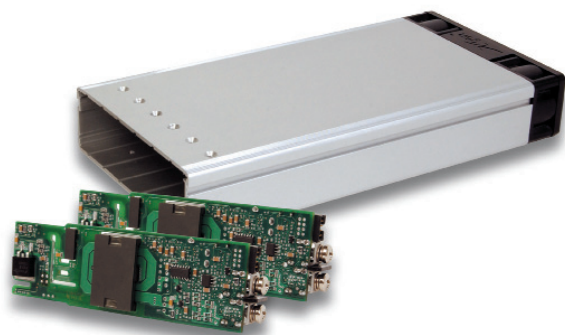

The *powerKit* family from the Excelsys Xgen series brings user convenience to a new paradigm for system design engineers tasked with development of system power supply solutions. The *powerKit* contains an application specific *powerPac* chassis module, along with a selection of user installable plug-in *powerMod* dc output modules. Each *powerMod* can be simply plugged in, removed and exchanged offering a remarkably powerful flexible system solution. Truly, for system design engineers, your dreams come true!

The feature-rich *powerMods* provide a suite of output signals and user configurable functions increasing design-in flexibility. User configurable functions include local and remote adjustment, adjustable current limit, alternative current limiting technique and inhibit/enable functions.

Employing high efficiency conversion techniques, Xgen series *powerMods* and *powerPacs* have minimal power losses, while the advanced packaging makes the Xgen series the smallest power supply in the industry.

### powerKits

MODEL	powerPac	Power	Application	Slots	Ref
XKC	Xcite	1200W	Standard	6	see Xcite datasheet
XKV	Xvite	1200W	Medical	6	see Xvite datasheet
XKH	Xhite	600W	Hi-Temp	6	see Xhite datasheet
XKQ	Xqite	900W	Low Noise	6	see Xqite datasheet
XKL	Xlite	600W	Standard	4	see Xlite datasheet
XKM	Xmite	600W	Medical	4	see Xmite datasheet

Each *powerKit* model contains ONE of each of the following *powerMods*

MODEL	Vmin	Vnom	Vmax	I <sub>max</sub>	I <sub>min</sub>	Type	Watts *	
Xg1	1.5	2.5	3.6	50A	0A	A	125W	
Xg2	3.2	5.0	6.0	40A	0A	A	200W	
Xg3	6.0	12.0	15.0	20A	0A	A	240W	
Xg4	12.0	24.0	30.0	10A	0A	A	240W	
Xg5	28.0	48.0	58.0	6A	0A	A	288W	
Xg7	5.0	24.0	28.0	5A	0A	AB	120W	
Xg8	V1	5.0	24.0	28.0	3A	0A	B**	72W
	V2	5.0	24.0	28.0	3A	0A		72W

\*Derate at 2.5% per °C above 50°C up to 70°C (maximum operating temperature)

\*\*See *powerMod* datasheets for details of *powerMod* types.

All *powerKits* are provided in an attractive rugged Xgen *powerKit* case specially designed for Excelsys to bring a new level of convenience to system engineers charged with power supply design.

Doc. 40043 rev.00 04/05

#### Europe/Asia

Excelsys Technologies Ltd t: +353 1 8900933  
Swords Business Park f: +353 1 8901358  
Swords, Co. Dublin e: sales@excelsys.com  
IRELAND

#### North America

Excelsys Technologies t: (972) 771 4544  
519 Interstate 30, #309 f: (972) 421 1805  
Rockwall, TX 75087 e: salesusa@excelsys.com  
USA