

FEATURES

- Dual Device Module
- Electrically Isolated Package
- Pressure Contact Construction
- International Standard Footprint
- Alumina (non-toxic) Isolation Medium

APPLICATIONS

- Motor Control
- Controlled Rectifier Bridges
- Heater Control
- AC Phase Control

VOLTAGE RATINGS

Type Number	Repetitive Peak Voltages		Conditions
	V_{DRM}	V_{RRM}	
MP02/190-14	1400		$T_{vj} = 125^{\circ}\text{C}$ $I_{DRM} = I_{RRM} = 30\text{mA}$ $V_{DSM} \text{ \& \ } V_{RSM} =$ $V_{DRM} \text{ \& \ } V_{RRM} + 100\text{V}$ respectively
MP02/190-12	1200		
MP02/190/10	1000		

Lower voltage grades available. For full description of part number see "Ordering Instructions" on page 3.

CURRENT RATINGS - PER ARM

Symbol	Parameter	Conditions	Max.	Units	
$I_{T(AV)}$	Mean on-state current	Halfwave, resistive load	$T_{case} = 75^{\circ}\text{C}$	190	A
			$T_{case} = 85^{\circ}\text{C}$	160	A
			$T_{heatsink} = 75^{\circ}\text{C}$	150	A
			$T_{heatsink} = 85^{\circ}\text{C}$	125	A
$I_{T(RMS)}$	RMS value	$T_{case} = 75^{\circ}\text{C}$	300	A	

KEY PARAMETERS

V_{DRM}	1400V
I_{TSM}	6800A
$I_{T(AV)}$ (per arm)	190A
V_{isol}	2500V

CIRCUIT OPTIONS

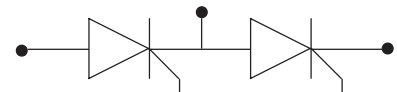
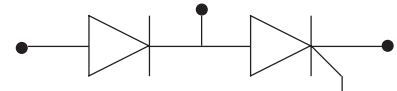
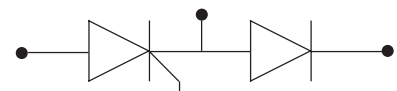
Code	Circuit
HBT	
HBP	
HBN	

PACKAGE OUTLINE

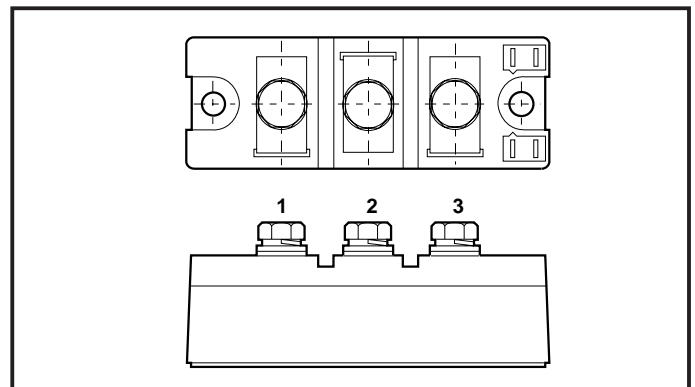

Module type code: MP02.

See Package Details for further information

MP02 XXX 190 Series

SURGE RATINGS - PER ARM

Symbol	Parameter	Conditions	Max.	Units	
I_{TSM}	Surge (non-repetitive) on-state current	10ms half sine; $T_j = 125^\circ\text{C}$	$V_R = 0$	6800	A
			$V_R = 50\% V_{RRM}$	5500	A
I^2t	I^2t for fusing	10ms half sine; $T_j = 125^\circ\text{C}$	$V_R = 0$	231000	A^2s
			$V_R = 50\% V_{RRM}$	150000	A^2s

THERMAL & MECHANICAL RATINGS

Symbol	Parameter	Conditions	Max.	Units
$R_{th(j-c)}$	Thermal resistance - junction to case per Thyristor or Diode	dc	0.17	$^\circ\text{C}/\text{W}$
		halfwave	0.18	$^\circ\text{C}/\text{W}$
		3 phase	0.19	$^\circ\text{C}/\text{W}$
$R_{th(c-hs)}$	Thermal resistance - case to heatsink per Thyristor or Diode	Mounting torque = 6Nm with mounting compound	0.07	$^\circ\text{C}/\text{W}$
T_{vj}	Virtual junction temperature		125	$^\circ\text{C}$
T_{sto}	Storage temperature range		-40 to 125	$^\circ\text{C}$
V_{isol}	Isolation voltage	Commoned terminals to base plate AC RMS, 1min, 50Hz	2.5	kV

DYNAMIC CHARACTERISTICS

Symbol	Parameter	Conditions	Max.	Units
V_{TM}	On-state voltage	At 1000A, $T_{case} = 25^\circ\text{C}$ - See Note 1	1.75	V
I_{RRM}/I_{DRM}	Peak reverse and off-state current	At V_{RRM}/V_{DRM} , $T_j = 125^\circ\text{C}$	30	mA
dV/dt	Linear rate of rise of off-state voltage	To 60% V_{DRM} , $T_j = 125^\circ\text{C}$	200*	$\text{V}/\mu\text{s}$
dI/dt	Rate of rise of on-state current	From 67% V_{DRM} to 400A Gate source 20V, 20 Ω Rise time 0.5 μs , $T_j = 125^\circ\text{C}$	100	$\text{A}/\mu\text{s}$
$V_{T(TO)}$	Threshold voltage	At $T_{vj} = 125^\circ\text{C}$ - See Note 1	1.05	V
r_T	On-state slope resistance	At $T_{vj} = 125^\circ\text{C}$ - See Note 1	0.80	m Ω

* Higher dV/dt values available, contact factory for particular requirements.

Note 1: The data given in this datasheet with regard to forward voltage drop is for calculation of the power dissipation in the semiconductor elements only. Forward voltage drops measured at the power terminals of the module will be in excess of these figures due to the impedance of the busbar from the terminal to the semiconductor.

GATE TRIGGER CHARACTERISTICS AND RATINGS

Symbol	Parameter	Conditions	Typ.	Max.	Units
V_{GT}	Gate trigger voltage	$V_{DRM} = 5V, T_{case} = 25^{\circ}C, R_L = 6\Omega$	-	3.0	V
I_{GT}	Gate trigger current	$V_{DRM} = 5V, T_{case} = 25^{\circ}C, R_L = 6\Omega$	-	200	mA
V_{GD}	Gate non-trigger voltage	$V_{DRM} = 5V, T_{case} = 25^{\circ}C$	-	0.2	V
V_{RGM}	Peak reverse gate voltage		-	5.0	V
I_{FGM}	Peak forward gate current	Anode positive with respect to cathode	-	4	A
P_{GM}	Peak gate power		-	16	W
$P_{G(AV)}$	Mean gate power		-	3	W

ORDERING INSTRUCTIONS

Part number is made up as follows:

MP02 HBT 190 - 16

MP = Pressure contact module
 02 = Outline type
 HBT = Circuit configuration code (see "circuit options" - front page)
 175 = Nominal average current rating at $T_{case} = 75^{\circ}C$
 16 = $V_{RRM}/100$

Examples:

MP02 HBP190-14
 MP02 HBN190-12

Note: Diode ratings and characteristics are comparable with SCR in types HBP or HBN.
 Types HBP or HBN can also be supplied with diode polarity reversed, to special order.

MOUNTING RECOMMENDATIONS

- Adequate heatsinking is required to maintain the base temperature at $75^{\circ}C$ if full rated current is to be achieved. Power dissipation may be calculated by use of $V_{T(TO)}$ and r_T information in accordance with standard formulae. We can provide assistance with calculations or choice of heatsink if required.
- The heatsink surface must be smooth and flat; a surface finish of N6 (32 μ in) and a flatness within 0.05mm (0.002") are recommended.
- Immediately prior to mounting, the heatsink surface should be lightly scrubbed with fine emery, Scotch Brite or a mild chemical etchant and then cleaned with a solvent to remove oxide build up and foreign material. Care should be taken to ensure no foreign particles remain.
- An even coating of thermal compound (eg. Unial) should be applied to both the heatsink and module mounting surfaces. This should ideally be 0.05mm (0.002") per surface to ensure optimum thermal performance.
- After application of thermal compound, place the module squarely over the mounting holes, (or 'T' slots) in the heatsink. Using a torque wrench, slowly tighten the recommended fixing bolts at each end, rotating each in turn no more than 1/4 of a revolution at a time. Continue until the required torque of 6Nm (55lb.ins) is reached at both ends.
- It is not acceptable to fully tighten one fixing bolt before starting to tighten the others. Such action may DAMAGE the module.

MP02 XXX 190 Series

CURVES

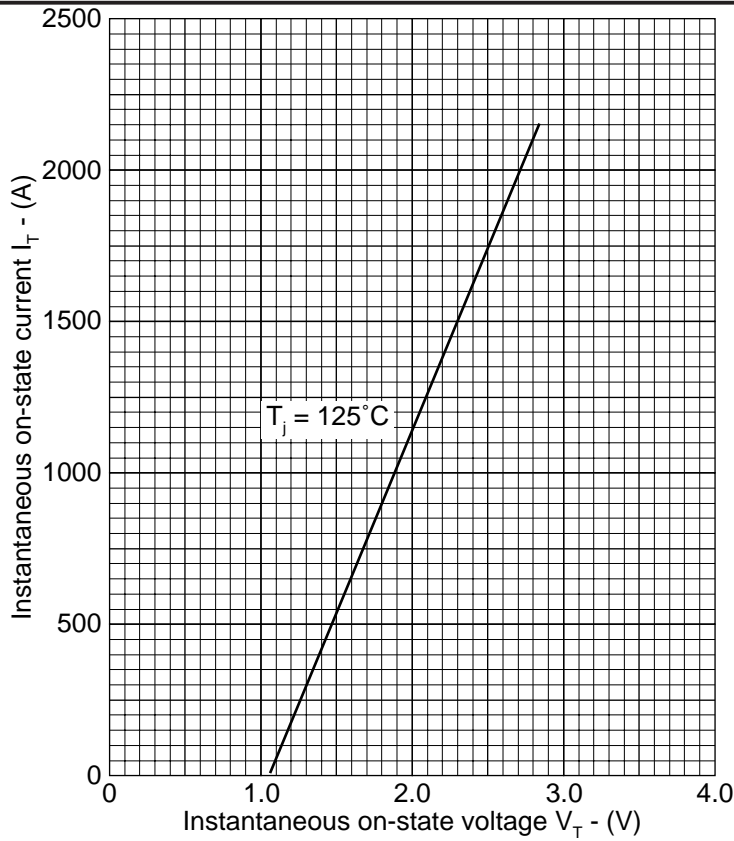

Fig. 1 Maximum (limit) on-state characteristics (thyristor or diode) - See Note 1

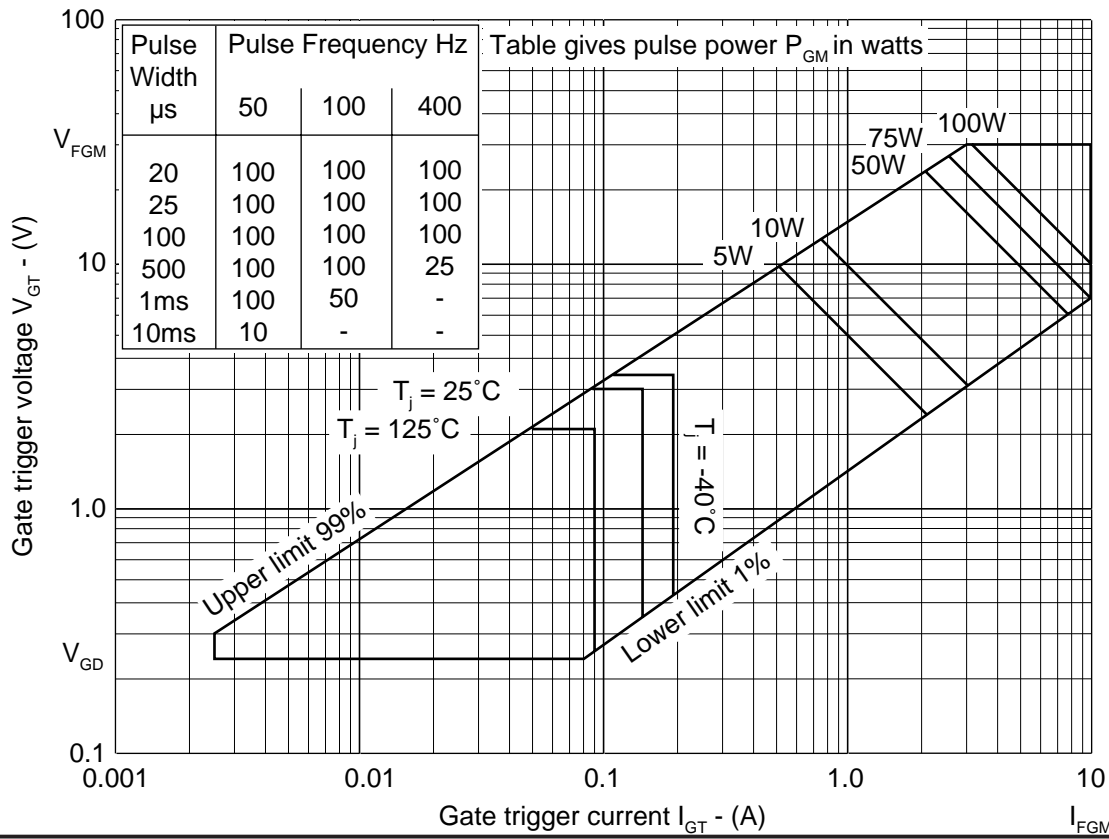

Fig. 2 Gate trigger characteristics

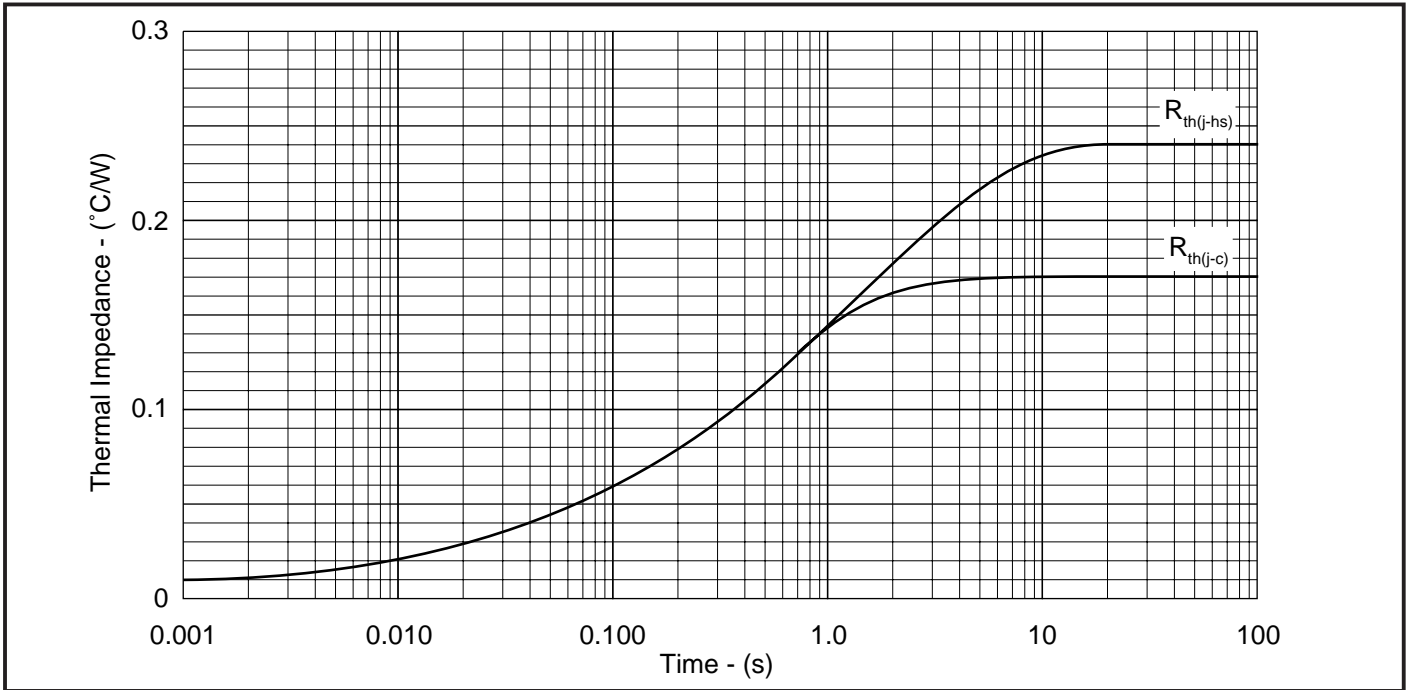

Fig. 3 Transient thermal impedance (DC) - (Thyristor or diode)

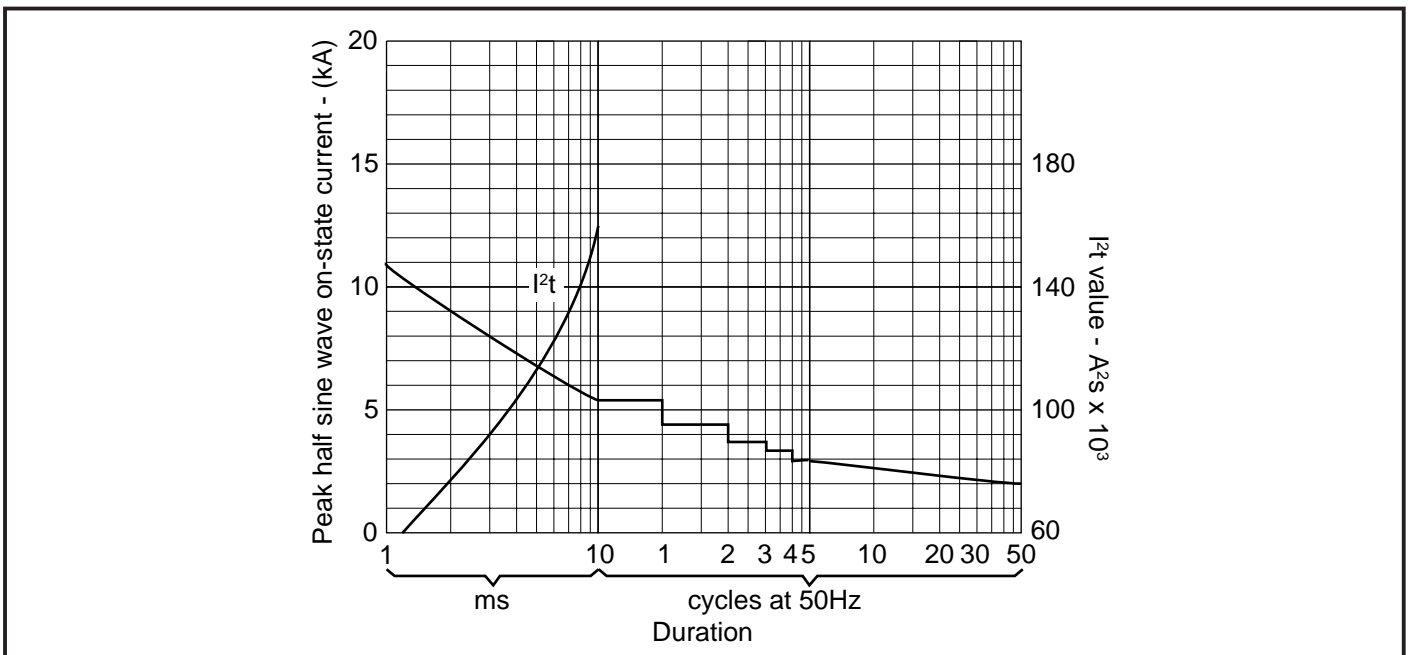

Fig. 4 Surge (non-repetitive) on-state current vs time (with 50% V_{RRM} , $T_{case} = 125^{\circ}\text{C}$ (Thyristor or diode))

MP02 XXX 190 Series

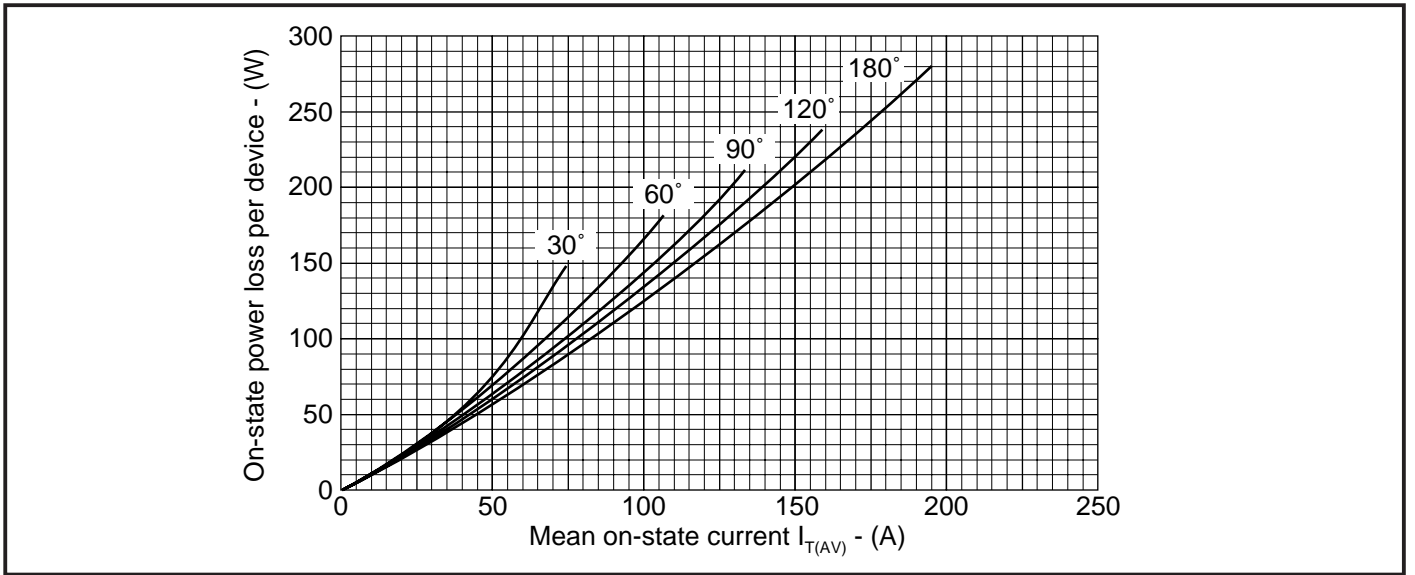

Fig. 5 On-state power loss per arm vs forward current at various conduction angles, sine wave, 50/60Hz

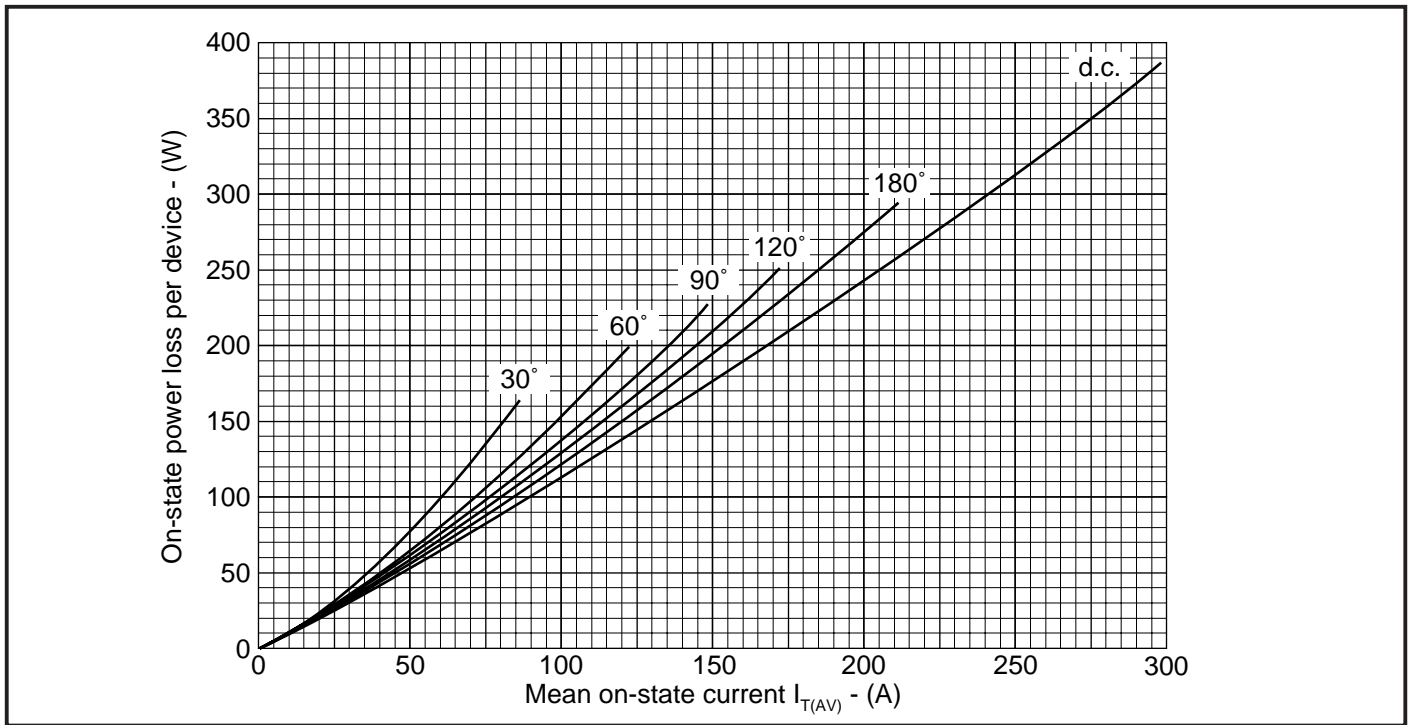

Fig. 6 On-state power loss per arm vs forward current at various conduction angles, square wave, 50/60Hz

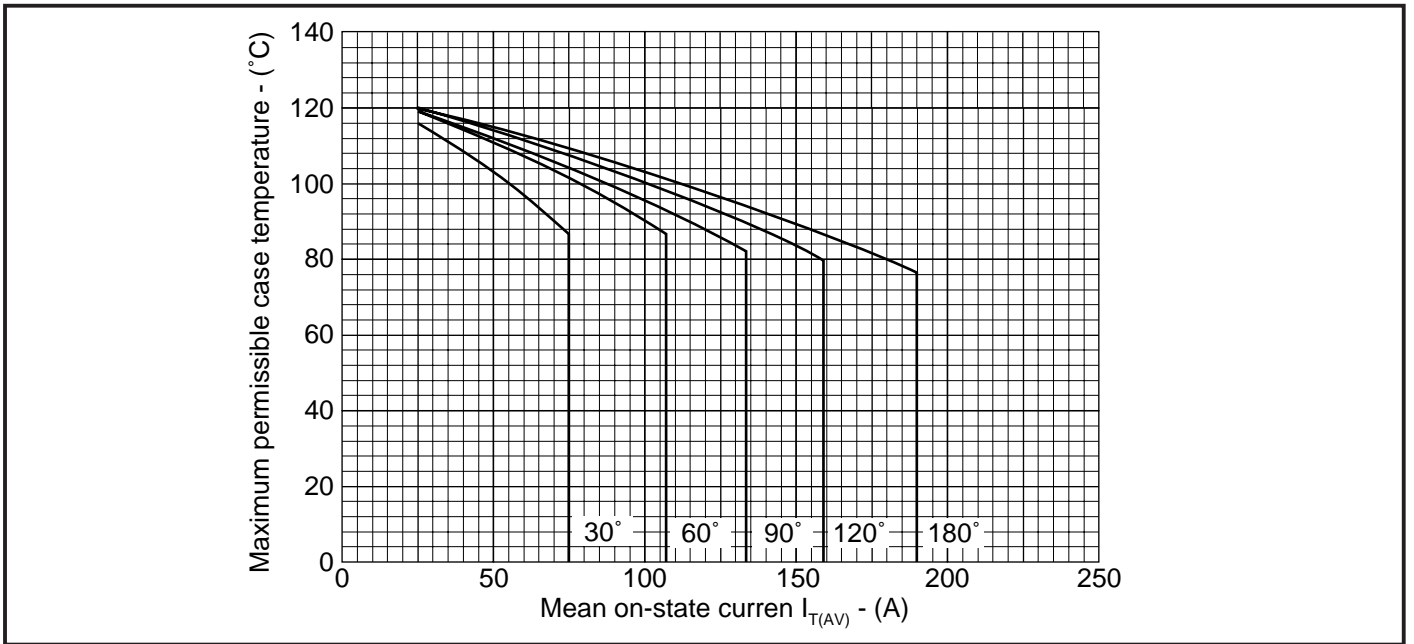

Fig. 7 Maximum permissible case temperature vs forward current per arm at various conduction angles, sine wave, 50/60Hz

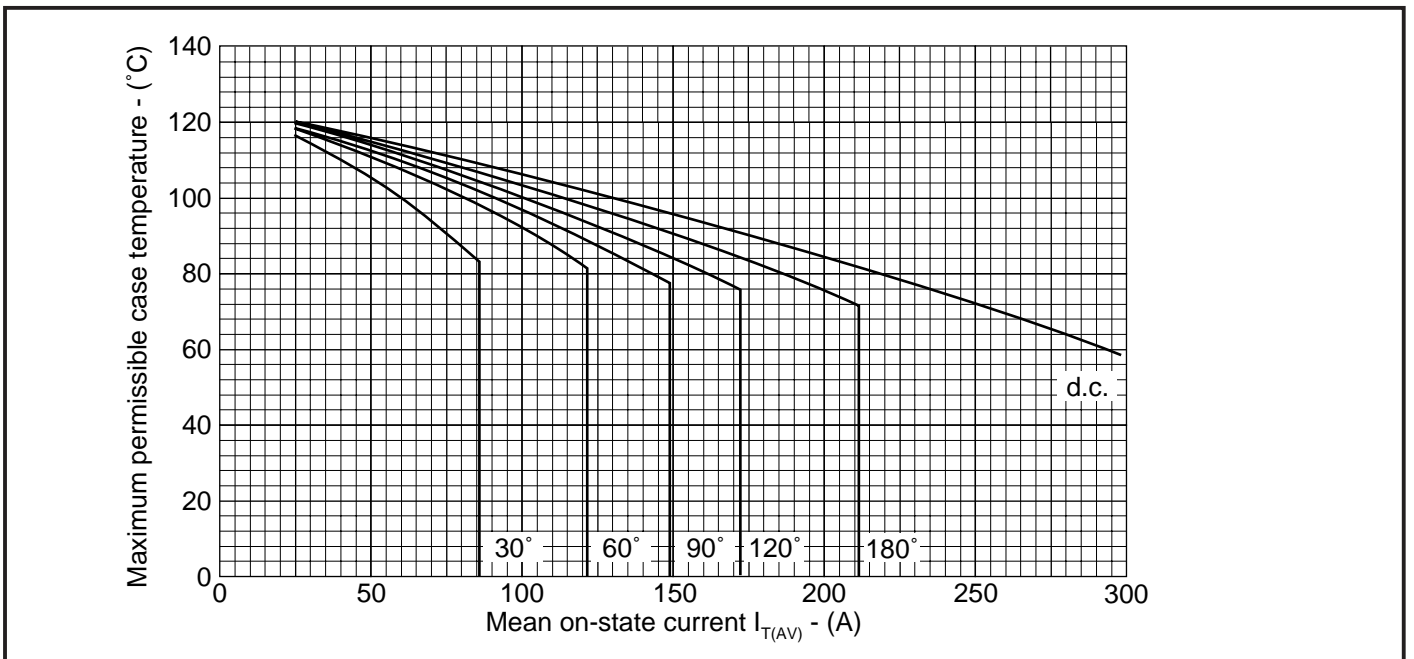

Fig. 8 Maximum permissible case temperature vs forward current per arm at various conduction angles, square wave, 50/60Hz

MP02 XXX 190 Series

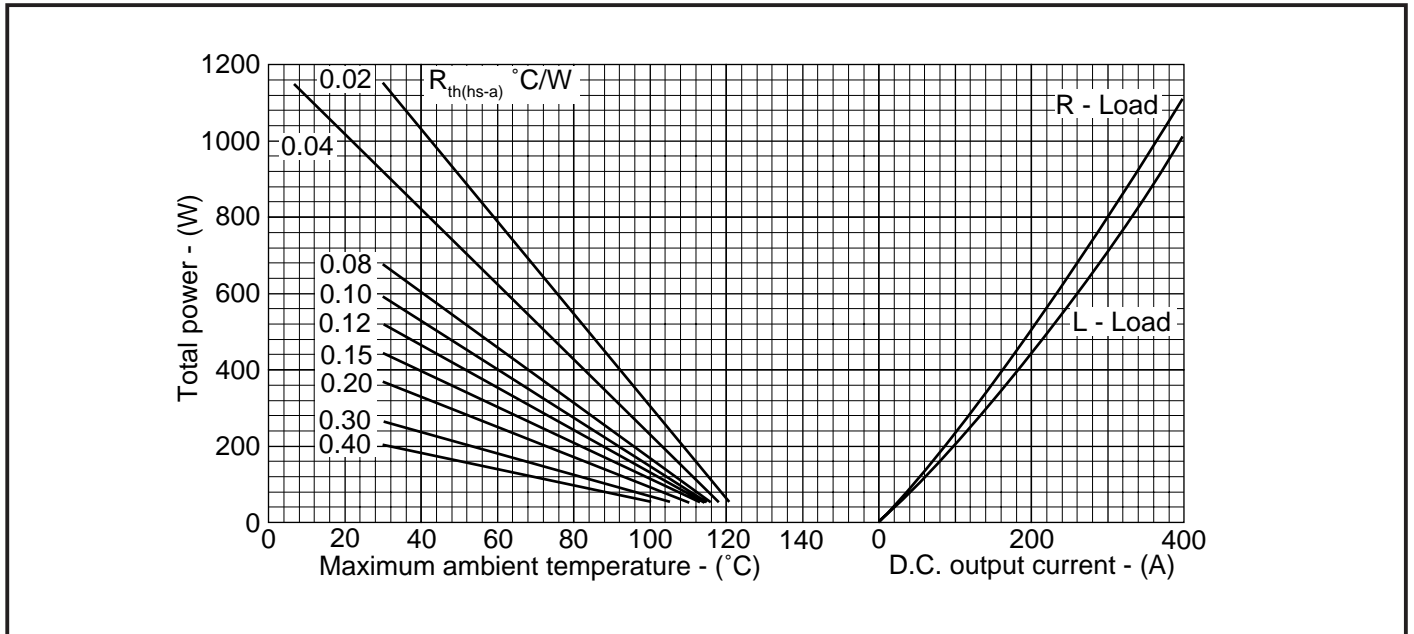

Fig. 9 50/60Hz single phase bridge dc output current vs power loss and maximum permissible ambient temperature for various values of heatsink thermal resistance.

(Note: $R_{th(hs-a)}$ values given above are true heatsink thermal resistances to ambient and already account for $R_{th(c-hs)}$ module contact thermal).

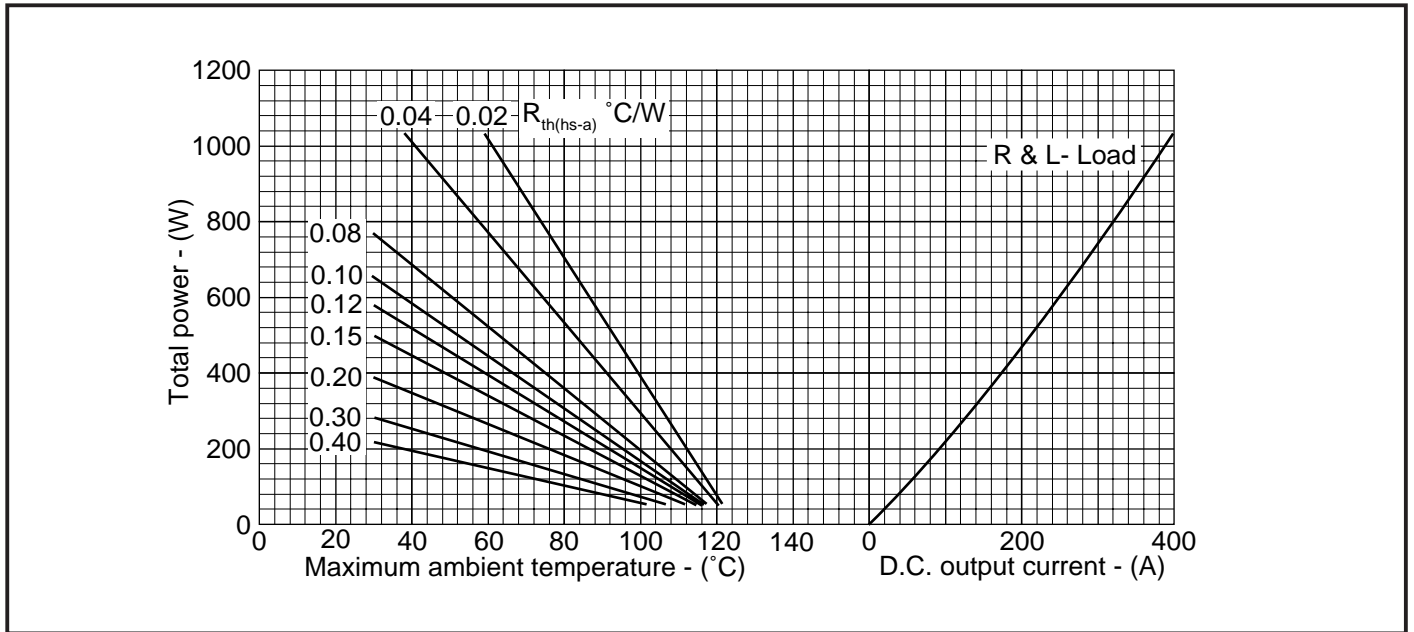
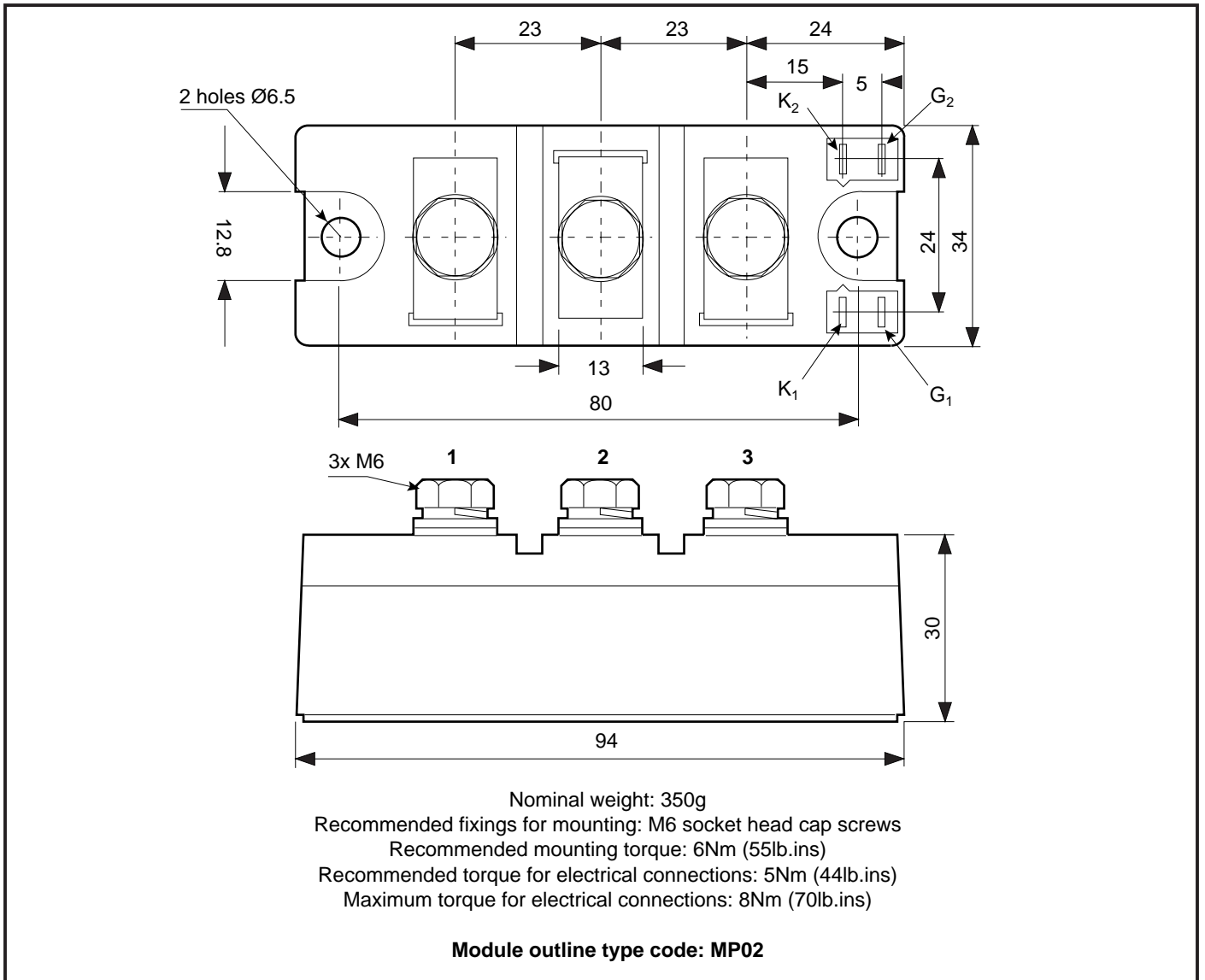

Fig. 9 50/60Hz 3- phase bridge dc output current vs power loss and maximum permissible ambient temperature for various values of heatsink thermal resistance.

(Note: $R_{th(hs-a)}$ values given above are true heatsink thermal resistances to ambient and already account for $R_{th(c-hs)}$ module contact thermal).

PACKAGE DETAILS

For further package information, please contact your local Customer Service Centre. All dimensions in mm, unless stated otherwise. DO NOT SCALE.



CIRCUIT CONFIGURATIONS

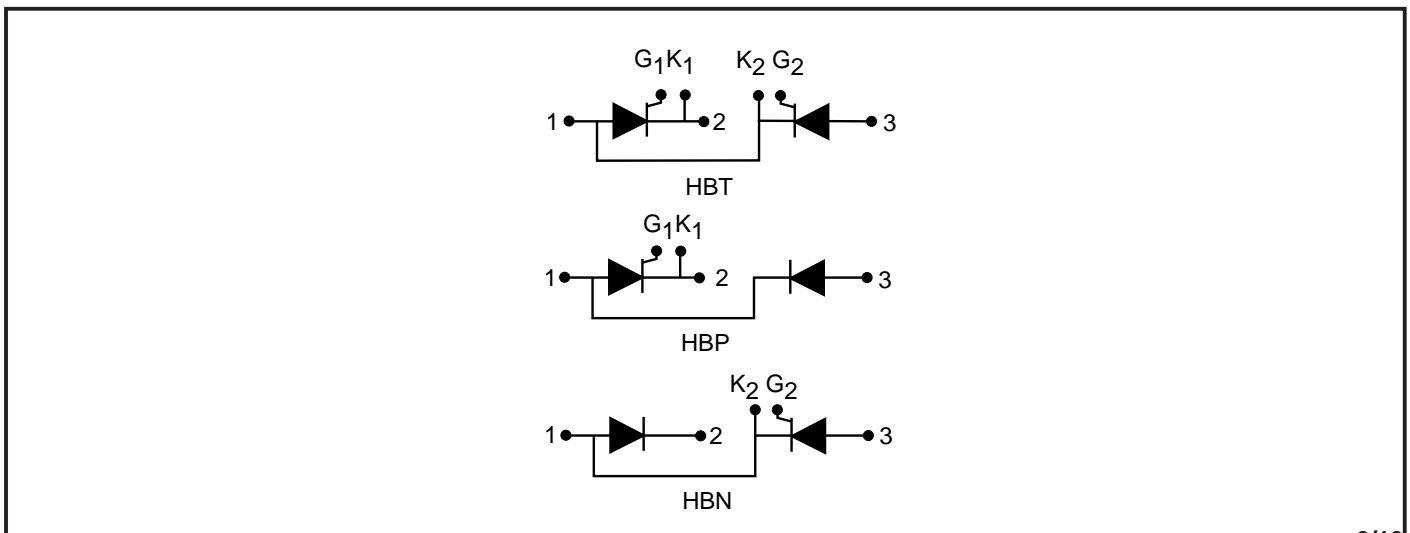

MP02 XXX 190 Series

ASSOCIATED PUBLICATIONS

Title	Application Note
	Number
Calculating the junction temperature of power semiconductors	AN4506
Recommendations for clamping power semiconductors	AN4839
Thyristor and diode measurement with a multi-meter	AN4853
Use of V_{TO} , r_T on-state characteristic	AN5001

POWER ASSEMBLY CAPABILITY

The Power Assembly group was set up to provide a support service for those customers requiring more than the basic semiconductor, and has developed a flexible range of heatsink / clamping systems in line with advances in device types and the voltage and current capability of our semiconductors.

We offer an extensive range of air and liquid cooled assemblies covering the full range of circuit designs in general use today. The Assembly group continues to offer high quality engineering support dedicated to designing new units to satisfy the growing needs of our customers.

Using the up to date CAD methods our team of design and applications engineers aim to provide the Power Assembly Complete solution (PACs).

HEATSINKS

Power Assembly has its own proprietary range of extruded aluminium heatsinks. They have been designed to optimise the performance of our semiconductors. Data with respect to air natural, forced air and liquid cooling (with flow rates) is available on request.

For further information on device clamps, heatsinks and assemblies, please contact your nearest Sales Representative or the factory.



<http://www.dynexsemi.com>

e-mail: power_solutions@dynexsemi.com

HEADQUARTERS OPERATIONS
DYNEX SEMICONDUCTOR LTD
Doddington Road, Lincoln.
Lincolnshire. LN6 3LF. United Kingdom.
Tel: 00-44-(0)1522-500500
Fax: 00-44-(0)1522-500550

DYNEX POWER INC.
Unit 7 - 58 Antares Drive,
Nepean, Ontario, Canada K2E 7W6.
Tel: 613.723.7035
Fax: 613.723.1518
Toll Free: 1.888.33.DYNEX (39639)

CUSTOMER SERVICE CENTRES
France, Benelux, Italy and Spain Tel: +33 (0)1 69 18 90 00. Fax: +33 (0)1 64 46 54 50
North America Tel: 011-800-5554-5554. Fax: 011-800-5444-5444
UK, Germany, Scandinavia & Rest Of World Tel: +44 (0)1522 500500. Fax: +44 (0)1522 500020

SALES OFFICES
France, Benelux, Italy and Spain Tel: +33 (0)1 69 18 90 00. Fax: +33 (0)1 64 46 54 50
Germany Tel: 07351 827723
North America Tel: (613) 723-7035. Fax: (613) 723-1518. Toll Free: 1.888.33.DYNEX (39639) /
Tel: (831) 440-1988. Fax: (831) 440-1989 / Tel: (949) 733-3005. Fax: (949) 733-2986.
UK, Germany, Scandinavia & Rest Of World Tel: +44 (0)1522 500500. Fax: +44 (0)1522 500020
These offices are supported by Representatives and Distributors in many countries world-wide.
© Dynex Semiconductor 2000 Publication No. DS4479-4 Issue No. 4.0 January 2000
TECHNICAL DOCUMENTATION – NOT FOR RESALE. PRINTED IN UNITED KINGDOM

Datasheet Annotations:

Dynex Semiconductor annotate datasheets in the top right hand corner of the front page, to indicate product status. The annotations are as follows:-

Target Information: This is the most tentative form of information and represents a very preliminary specification. No actual design work on the product has been started.

Preliminary Information: The product is in design and development. The datasheet represents the product as it is understood but details may change.

Advance Information: The product design is complete and final characterisation for volume production is well in hand.

No Annotation: The product parameters are fixed and the product is available to datasheet specification.

This publication is issued to provide information only which (unless agreed by the Company in writing) may not be used, applied or reproduced for any purpose nor form part of any order or contract nor to be regarded as a representation relating to the products or services concerned. No warranty or guarantee express or implied is made regarding the capability, performance or suitability of any product or service. The Company reserves the right to alter without prior notice the specification, design or price of any product or service. Information concerning possible methods of use is provided as a guide only and does not constitute any guarantee that such methods of use will be satisfactory in a specific piece of equipment. It is the user's responsibility to fully determine the performance and suitability of any equipment using such information and to ensure that any publication or data used is up to date and has not been superseded. These products are not suitable for use in any medical products whose failure to perform may result in significant injury or death to the user. All products and materials are sold and services provided subject to the Company's conditions of sale, which are available on request.

All brand names and product names used in this publication are trademarks, registered trademarks or trade names of their respective owners.