



## HIGH TEMPERATURE CRYSTALS

High Temperature/High Shock/High Frequency

### DESCRIPTION

An increasing number of applications require the use of high-temperature crystals. For these applications, Statek offers the CX1 HT, CX4 HT, and CX9 HT crystals. These crystals are designed to operate at temperatures up to and including 225°C. The frequency range offered is 6 MHz to 250 MHz for CX1HT and 14 MHz to 250 MHz for CX4HT and CX9HT crystals. The expected life at 200°C is in excess of 1,000 hours.

### FEATURES

- High temperature operation up to 225°C
- High shock resistance
- Hermetically sealed ceramic package

### APPLICATIONS

#### Industrial

- Downhole instrumentation
- Rotary shaft sensors
- Underground boring tools



### DIMENSIONS

DIM	CX1HT MAXIMUM		CX4HT MAXIMUM		CX9HT MAXIMUM	
	inches	mm	inches	mm	inches	mm
A	0.330	8.38	0.210	5.33	0.170	4.32
B	0.155	3.94	0.085	2.16	0.068	1.73
C (SM1)	0.070	1.78	0.050	1.27	0.038	0.97
C (SM5)	0.075	1.90	0.053	1.35	0.040	1.02
D	0.055	1.40	0.046	1.16	0.038	0.97
E	0.070	1.78	0.020	0.51	—	—
F	0.070	1.78	0.025	0.64	—	—

### PACKAGE DIMENSIONS

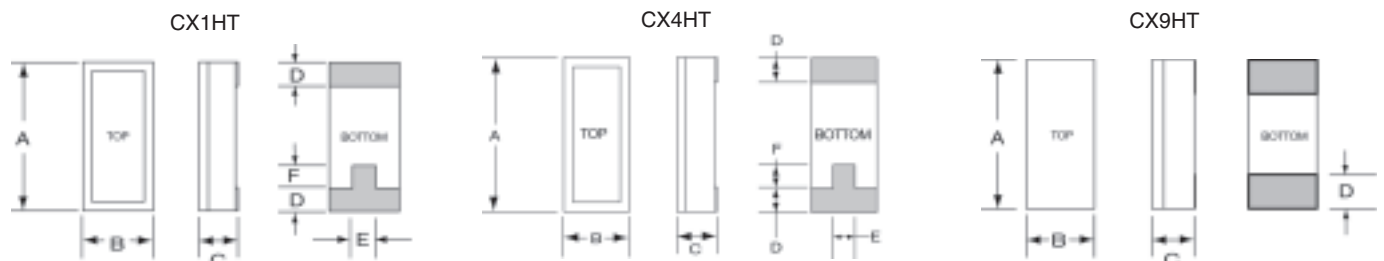

### SUGGESTED LAND PATTERN

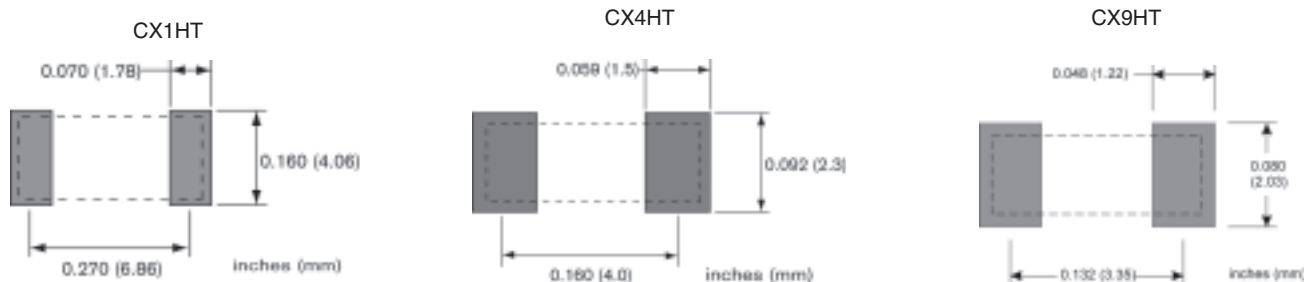

## SPECIFICATIONS

Specifications are typical at 25°C unless otherwise noted.  
Specifications are subject to change without notice.

Frequency Range	See Specifications Table below
Calibration Tolerance <sup>1</sup>	± 100 ppm, or tighter, as required
Operating Temperature Range	-55°C up to +225°C
Frequency-Temperature Stability <sup>2</sup>	± 125 ppm for -55°C to +150°C ± 150 ppm for -55°C to +175°C ± 175 ppm for -55°C to +200°C ± 250 ppm for -55°C to +225°C
Total Tolerance <sup>3</sup>	± 200 ppm for +25°C to +200°C ± 300 ppm for +25°C to +225°C
Aging, first year	5 ppm at 25°C
Shock, survival <sup>4</sup>	CX1HT: 1,000 g, 1 ms, 1/2 sine CX4HT: 5,000 g, 0.3 ms, 1/2 sine CX9HT: 5,000 g, 0.3 ms, 1/2 sine
Vibration, survival <sup>4</sup>	20 g RMS, 10-2,000 Hz

1. Tighter frequency calibration available. Contact factory
2. Does not include calibration tolerance. The characteristics of the frequency stability over temperature follow that of the thickness-shear mode.
3. Includes calibration tolerance.
4. Higher shock and vibration available.

## ABSOLUTE MAXIMUM RATINGS

Storage Temperature	-55°C to 125°C
Maximum Process Temperature	260°C for 20 seconds

## PACKAGING OPTIONS

- Tray Pack
  - 16 mm tape, 7" or 13" reels
- Per EIA 481 (see Tape and Reel data sheet # 10109)

## CONVENTIONAL CMOS PIERCE OSCILLATOR CIRCUIT

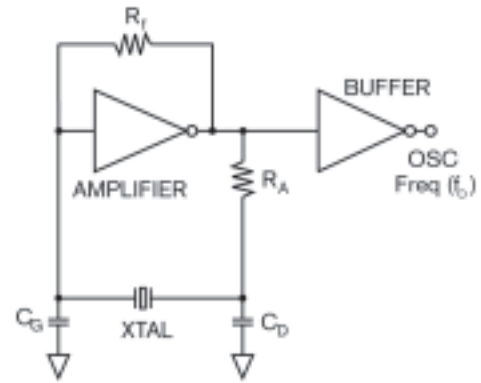

## SPECIFICATIONS TABLE<sup>1</sup> (Specifications shown are typical unless otherwise noted.)

	Frequency Range	Motional Resistance R1 @ 25°C	Motional Capacitance C1 @ 25°C	Shunt Capacitance C0 @ 25°C	Quality Factor Q @ 25°C	Load Capacitance CL Load	Drive Level
CX1HT	6 MHz to 250 MHz	30 Ω @ 10 MHz 25 Ω @ 32 MHz	5.5 fF @ 10 MHz 6.2 fF @ 32 MHz	2.2 pF @ 10 MHz 2.3 pF @ 32 MHz	100 K @ 10 MHz 30 K @ 32 MHz	10 pF	500 μW MAX. for f < 50 MHz 200 μW MAX. for f > 50 MHz
	14 MHz to 250 MHz	75 Ω @ 16 MHz 30 Ω @ 32 MHz	1.5 fF @ 16 MHz 2.5 fF @ 32 MHz	0.9 pF @ 16 MHz 1.1 pF @ 32 MHz	90 K @ 16 MHz 70 K @ 32 MHz		200 μW MAX. for f < 50 MHz 100 μW MAX. for f > 50 MHz
CX4HT	14 MHz to 250 MHz	30 Ω @ 25 MHz 30 Ω @ 49 MHz	1.8 fF @ 25 MHz 2.1 fF @ 49 MHz	1.0 pF @ 25 MHz 1.0 pF @ 49 MHz	120K @ 25 MHz 60 K @ 49 MHz	10 pF	200 μW MAX. for f < 50 MHz 100 μW MAX. for f > 50 MHz
	14 MHz to 250 MHz	30 Ω @ 25 MHz 30 Ω @ 49 MHz	1.8 fF @ 25 MHz 2.1 fF @ 49 MHz	1.0 pF @ 25 MHz 1.0 pF @ 49 MHz	120K @ 25 MHz 60 K @ 49 MHz		200 μW MAX. for f < 50 MHz 100 μW MAX. for f > 50 MHz

1. For more detailed specifications on high frequency crystals, refer to standard high frequency crystal datasheets (CX1SM, CX4 SM and CX9SM.)

## HOW TO ORDER CX1HT, CX4HT and CX9HT CRYSTALS

