

AS1346, AS1347, AS1348, AS1349 Dual Step-Down Converter with Battery Monitoring

1 General Description

The AS1346, AS1347, AS1348, AS1349 family is a high-efficiency, constant-frequency dual buck converter available with fixed voltage versions. The device provides two independent DC/DC Converters with output currents between 0.5A and 1.2A. The wide input voltage range (2.7V to 5.5V), automatic powersave mode and minimal external component requirements make the AS134x family perfect for SSD and many other battery-powered applications.

In shutdown mode the typical supply current decreases to $\leq 1\mu\text{A}$. The highly efficient duty cycle (100%) provides low dropout operation, prolonging battery life in portable systems.

An internal synchronous switching scheme increases efficiency and eliminates the need for an external Schottky diode. The fixed switching frequency (2.0MHz) allows the use of small surface mount inductors.

The integrated monitoring function can be configured that either the output voltage (Power Okay function) or the input voltage (Battery Monitoring Function) can be supervised.

Table 1. Available Products

Devices	IOUT1	IOUT2
AS1346	1.2A	0.5A
AS1347	0.5A	0.5A
AS1348	0.5A	0.95A
AS1349	1.2A	1.2A

The AS1346 is available in a 12-Pin TDFN 3x3mm package.

2 Key Features

- High Efficiency: Up to 95%
- Output Current: see Table 1
- Input Voltage Range: 2.7V to 5.5V
- Output Voltage Range: 1.2V to 3.6V (available in 100mV steps)
- Constant Frequency Operation: 2.0MHz
- 180° Out of Phase Operation
- Low Battery Detection
- Low Dropout Operation: 100% Duty Cycle
- Shutdown Mode Supply Current: $\leq 1\mu\text{A}$
- No Schottky Diode Required
- Output Disconnect in Shutdown
- Non standard variants available within two weeks
- 12-Pin TDFN 3x3mm Package

3 Applications

The device is ideal for SSD applications, mobile communication devices, laptops and PDAs, ultra-low-power systems, threshold detectors/discriminators, telemetry and remote systems, medical instruments, or any other space-limited application with low power-consumption requirements.

Figure 1. AS1346 - Typical Application Diagram with POK Function

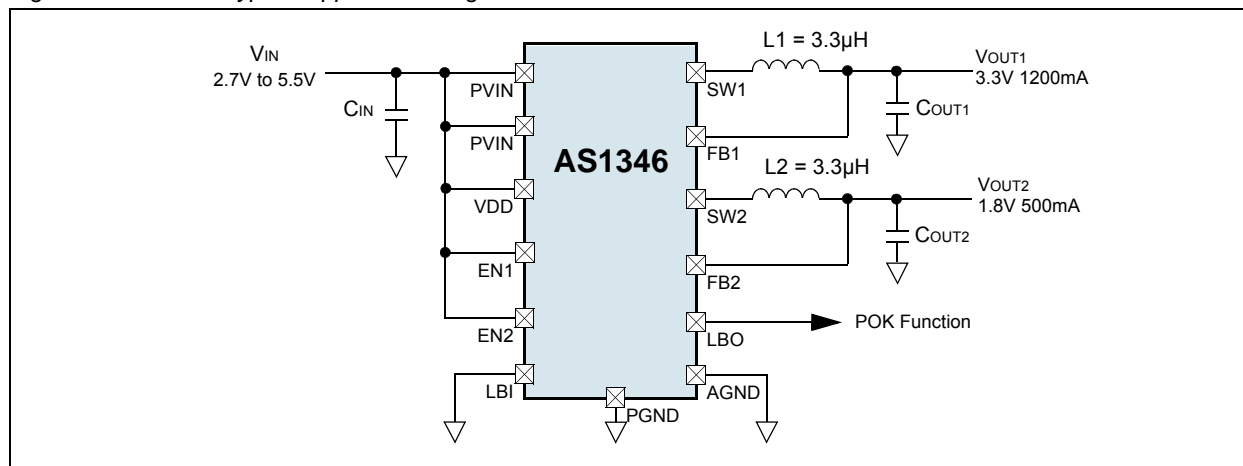

4 Pin Assignments

Figure 2. Pin Assignments (Top View)

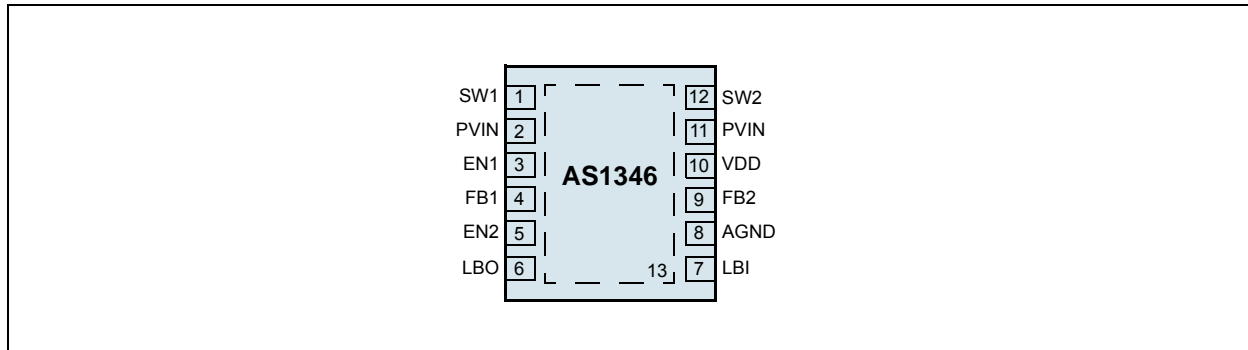

Pin Descriptions

Table 2. Pin Descriptions

Pin Number	Pin Name	Description
1	SW1	Switch Node1 Connection to Inductor. This pin connects to the drains of the internal main and synchronous power MOSFET switches.
2, 11	PVIN	Power Supply Connector. This pin must be closely decoupled to PGND with a $\geq 4.7\mu\text{F}$ ceramic capacitor.
3	EN1	Enable1 Input. Driving this pin above 1.2V enables $V_{\text{OUT}1}$. Driving this pin below 0.5V puts the device in shutdown mode. In shutdown mode all functions are disabled, drawing $\leq 1\mu\text{A}$ supply current. This pin should not be left floating.
4	FB1	Feedback Pin 1. Feedback input to the error amplifier, connect this pin to $V_{\text{OUT}1}$. The output can be factory set from 1.2V to 3.6V. For further information see Ordering Information on page 14 .
5	EN2	Enable2 Input. Driving this pin above 1.2V enables $V_{\text{OUT}2}$. Driving this pin below 0.5V puts the device in shutdown mode. In shutdown mode all functions are disabled, drawing $\leq 1\mu\text{A}$ supply current. This pin should not be left floating.
6	LBO	Low Battery Comperator Output. This open-drain output is low when the voltage on LBI is less than 1.2V.
7	LBI	Low Battery Comperator Input. 1.2V Threshold. May not be left floating. If connected to GND, LBO is working as Output Power Okay for $V_{\text{OUT}1}$.
8	AGND	Analog Ground.
9	FB2	Feedback 2 Pin. Feedback input to the error amplifier, connect this pin to $V_{\text{OUT}2}$. The output can be factory set from 1.2V to 3.6V. For further information see Ordering Information on page 14 .
10	VDD	Supply Connector. Connect this pin to PVIN
12	SW2	Switch Node2 Connection to Inductor. This pin connects to the drains of the internal main and synchronous power MOSFET switches.
13	PGND	Exposed Pad. The exposed pad must be connected to AGND. Ensure a good electrical connection to the PCB to achieve optimal thermal performance.

5 Absolute Maximum Ratings

Stresses beyond those listed in [Table 3](#) may cause permanent damage to the device. These are stress ratings only, and functional operation of the device at these or any other conditions beyond those indicated in [Electrical Characteristics on page 4](#) is not implied. Exposure to absolute maximum rating conditions for extended periods may affect device reliability.

Table 3. Absolute Maximum Ratings

Parameter	Min	Max	Units	Notes
VDD, PVIN to AGND	-0.3	+7.0	V	
PGND to AGND	-0.3	+0.3	V	
EN, FB	AGND - 0.3	VDD + 0.3	V	7.0V max
SW	PGND - 0.3	PVIN + 0.3	V	
PVIN to VDD	-0.3	+0.3	V	
Operating Temperature Range	-40	+85	°C	
Junction Temperature (T _{J-MAX})		+150	°C	
Storage Temperature Range	-65	+150	°C	
Maximum Lead Temperature (Soldering, 10 sec)		+260	°C	
ESD Rating				
Human Body Model		1	kV	HBM MIL-Std. 883E 3015.7 methods
Operating Ratings				
Input Voltage Range		5.5	V	
			mA	
Junction Temperature (T _J) Range	-40	+125	°C	
Ambient Temperature (T _A) Range	-40	+85	°C	<p>In applications where high power dissipation and/or poor package thermal resistance is present, the maximum ambient temperature may have to be derated.</p> <p>Maximum ambient temperature (T_{A-MAX}) is dependent on the maximum operating junction temperature (T_{J-MAX-OP} = 125°C), the maximum power dissipation of the device in the application (P_{D-MAX}), and the junction-to ambient thermal resistance of the part/package in the application (θ_{JA}), as given by the following equation: T_{A-MAX} = T_{J-MAX-OP} - (θ_{JA} × P_{D-MAX}).</p>

6 Electrical Characteristics

$T_A = T_J = -40^{\circ}\text{C}$ to $+85^{\circ}\text{C}$; $P_{VIN} = V_{DD} = EN = 5\text{V}$, unless otherwise noted. Typ. values are at $T_A = 25^{\circ}\text{C}$.

Table 4. Electrical Characteristics

Symbol	Parameter	Conditions	Min	Typ	Max	Units
V_{IN}	Input Voltage Range	$V_{IN} \geq V_{OUT}$	2.7		5.5	V
V_{OUT}	Output Voltage Range	(see Table 7 on page 14)	1.2		3.6	V
I_Q	Quiescent Supply Current ¹			2	2.8	mA
I_{OUT1}	Output current 1	AS1346, $V_{OUT1} = 3.3\text{V}$		1200		mA
		AS1347		500		mA
		AS1348		500		mA
		AS1349		1200		mA
I_{OUT2}	Output current 2	AS1346, $V_{OUT2} = 1.8\text{V}$		500		mA
		AS1347		500		mA
		AS1348		950		mA
		AS1349		1200		mA
I_{SHDN}	Shutdown Current			0.1	1	μA
Regulation						
V_{OUT1}	Output Voltage 1	AS1346, $I_{OUT1} = 100\text{mA}$	3.234	3.3	3.366	V
	Accuracy			± 2		%
V_{OUT2}	Output Voltage 2	AS1346, $I_{OUT2} = 100\text{mA}$	1.764	1.8	1.836	V
	Accuracy			± 2		%
	Line Transient Response	$V_{IN} = 4.5\text{V}$ to 5.5V , $I_{OUT1} = 500\text{mA}$, $V_{OUT1} = 3.3\text{V}$, $EN2 = 0\text{V}$		50		mVpk
	Load Transient Response	$V_{IN} = 5\text{V}$, $I_{OUT1} = 0$ to 500mA , $V_{OUT1} = 3.3\text{V}$, $EN2 = 0\text{V}$		50		mVpk
f_{OSC}	Oscillator frequency		1.8	2	2.2	MHz
t_{ON}	Turn on time			350		μs
DC-DC Switches						
I_{SW1}	SW1 Current Limit	AS1346		1.55		A
I_{SW2}	SW2 Current Limit	AS1346		800		mA
$R_{DS(ON)1(P)}$	Pin-Pin Resistance for PMOS1	$V_{DD} = 5.0\text{V}$, $I_{SW} = 200\text{mA}$		150		$\text{m}\Omega$
$R_{DS(ON)1(N)}$	Pin-Pin Resistance for NMOS1	$V_{DD} = 5.0\text{V}$, $I_{SW} = 200\text{mA}$		250		$\text{m}\Omega$
$R_{DS(ON)2(P)}$	Pin-Pin Resistance for PMOS2	$V_{DD} = 5.0\text{V}$, $I_{SW} = 200\text{mA}$		150		$\text{m}\Omega$
$R_{DS(ON)2(N)}$	Pin-Pin Resistance for NMOS2	$V_{DD} = 5.0\text{V}$, $I_{SW} = 200\text{mA}$		250		$\text{m}\Omega$

Table 4. Electrical Characteristics

Symbol	Parameter	Conditions	Min	Typ	Max	Units
Enable						
V _{IH,EN}	Logic high input threshold		1.2			V
V _{IH,EN}	Logic low input threshold				0.5V	V
Low Battery & Power-OK						
V _{LBI}	LBI Threshold	Falling Edge	1.16	1.2	1.24	V
	LBI Hysteresis			10		mV
	LBI Leakage Current	LBI = 5V, T _A = 25°C		1		nA
	LBO Voltage Low ²	I _{LBO} = 0.1mA		0.05		V
	LBO Leakage Current	LBO = 5V, T _A = 25°C		1		nA
	Power-OK Threshold	LBI = 0V, Falling Edge	85	88	90	%

- The dynamic supply current is higher due to the gate charge delivered at the switching frequency. The Quiescent Current is measured while the DC-DC Converter is not switching.
- LBO goes low in startup mode as well as during normal operation if:
 - The voltage at the LBI pin is below LBI threshold.
 - The voltage at the LBI pin is below 0.1V and V_{OUT} is below 92.5% of its nominal value.

Note: All limits are guaranteed. The parameters with min and max values are guaranteed with production tests or SQC (Statistical Quality Control) methods.

7 Typical Operating Characteristics

Figure 3. AS1346 Efficiency vs. I_{OUT} , $V_{OUT1} = 3.3V$

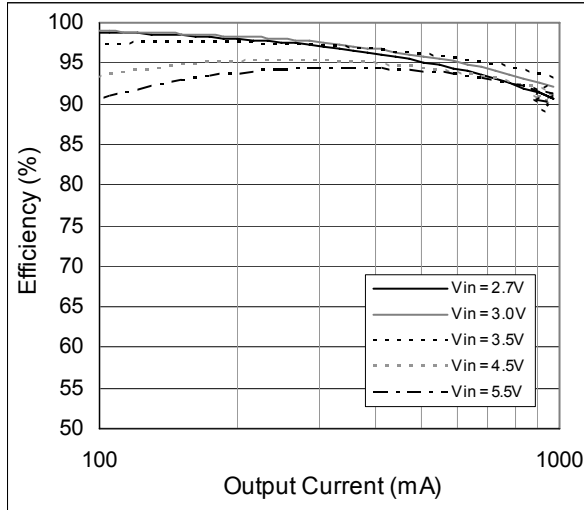

Figure 4. AS1346 Efficiency vs. I_{OUT} , $V_{OUT2} = 1.8V$

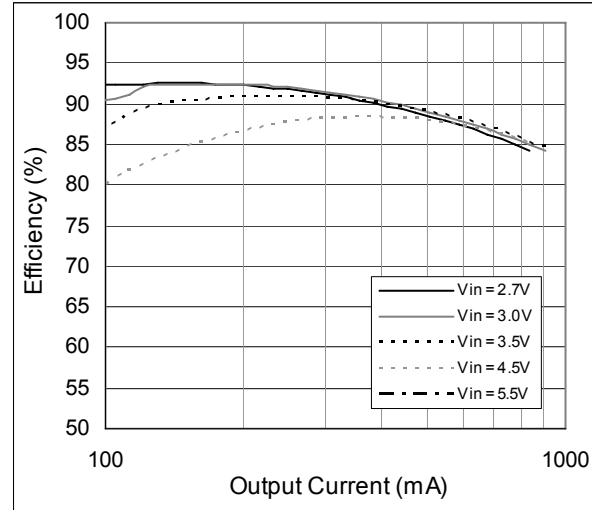

Figure 5. AS1346 Efficiency vs. V_{IN} , $V_{OUT1} = 3.3V$

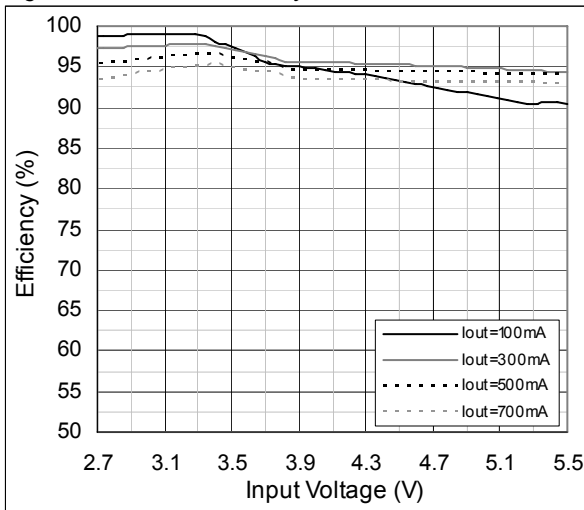

Figure 6. AS1346 Efficiency vs. V_{IN} , $V_{OUT2} = 1.8V$

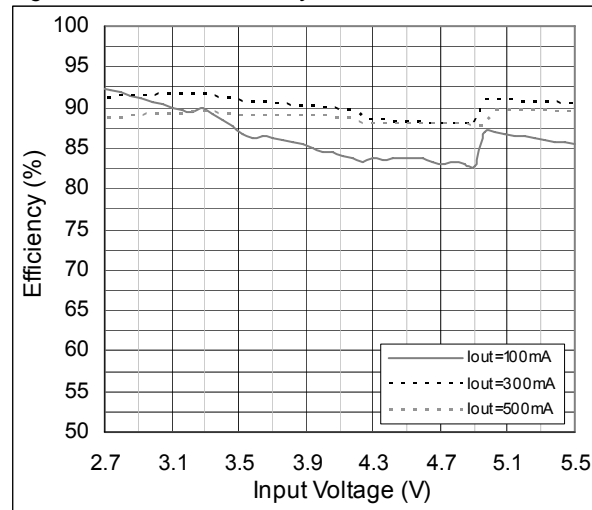

Figure 7. Efficiency vs. I_{OUT} , $V_{OUT1} = 2.5V$

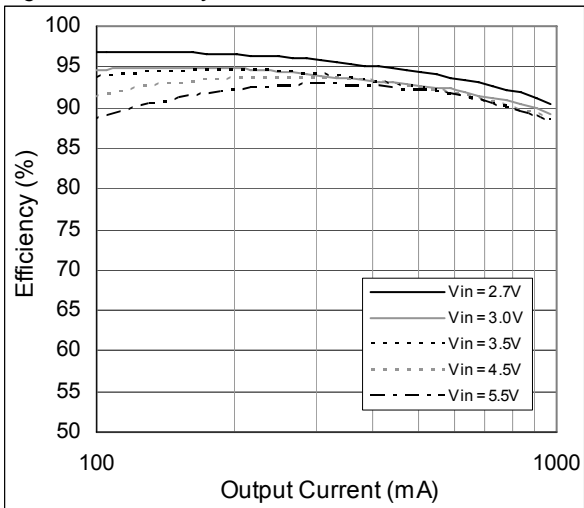

Figure 8. Efficiency vs. I_{OUT} , $V_{OUT2} = 1.2V$

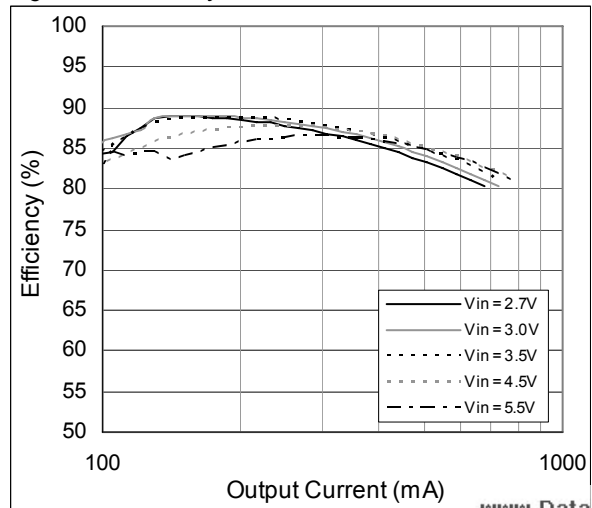

Figure 9. AS1346 Load Regulation; $V_{IN} = 4.0V$, $V_{OUT1} = 3.3V$

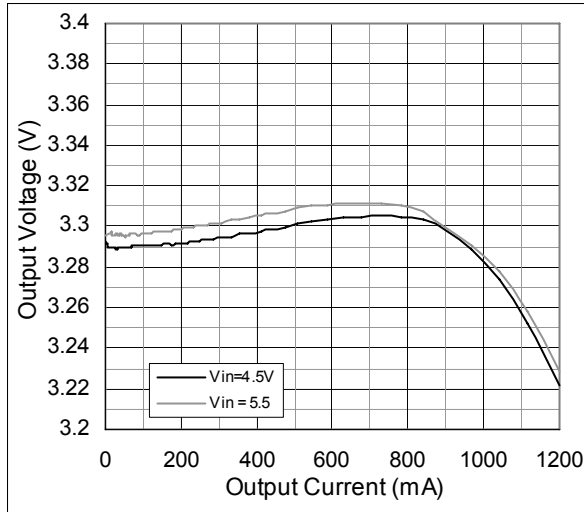

Figure 10. AS1346 Load Regulation; $V_{IN} = 4.0V$, $V_{OUT2} = 1.8V$

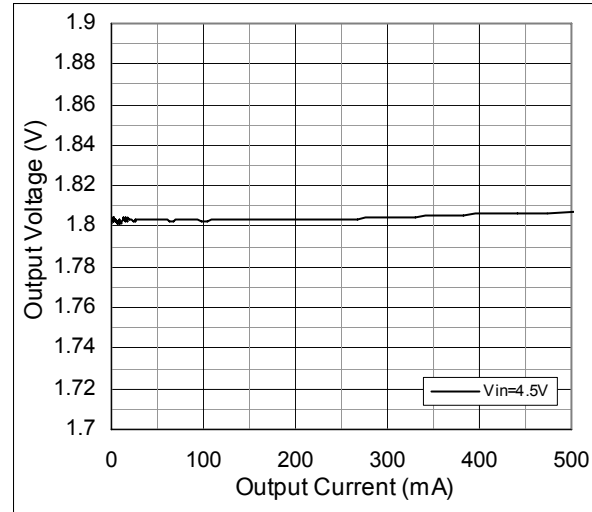

Figure 11. AS1346 Line Regulation, $V_{OUT1} = 3.3V$

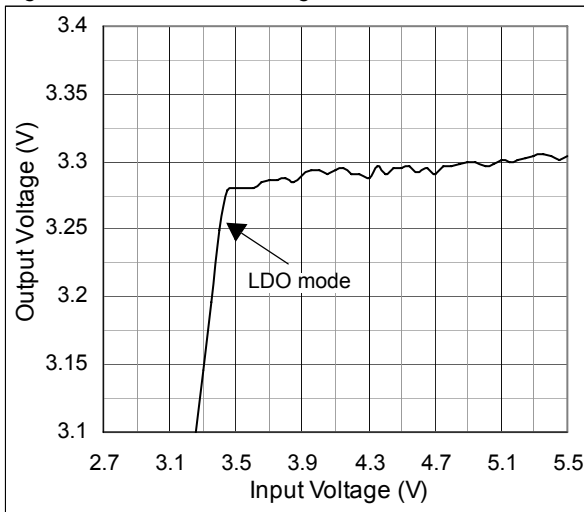

Figure 12. AS1346 Line Regulation, $V_{OUT2} = 1.8V$

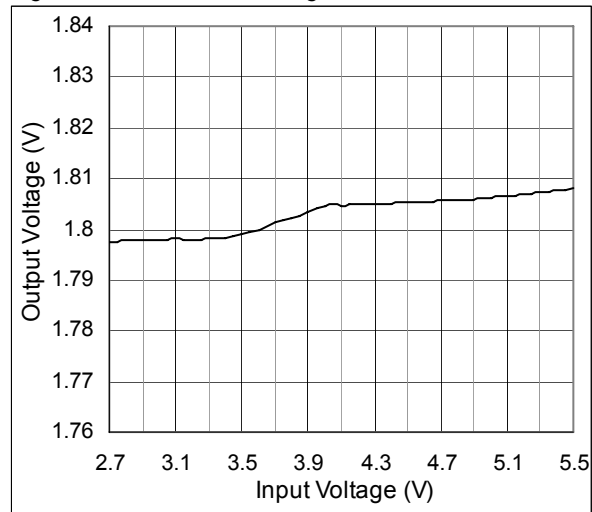

Figure 13. AS1346 V_{OUT} vs. Temperature; $V_{IN} = 5.5V$, $I_{OUT} = 1A$

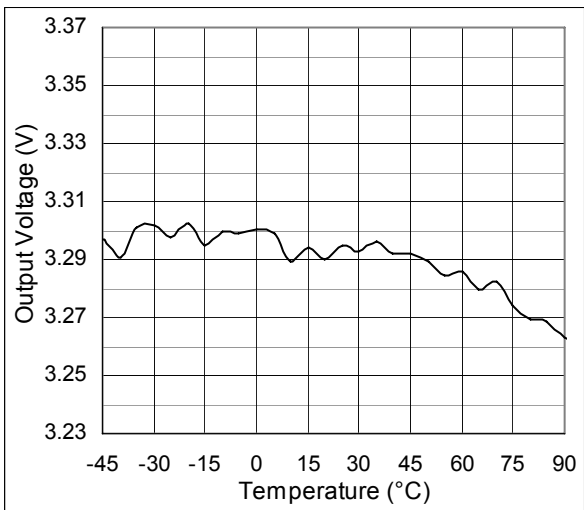

Figure 14. AS1346 V_{OUT} vs. Temperature; $V_{IN} = 5.5V$, $I_{OUT} = 500mA$

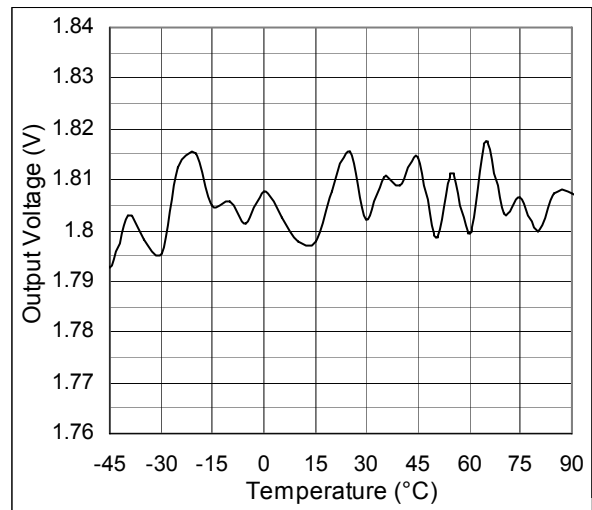

Figure 15. AS1346 I_q vs. V_{IN}

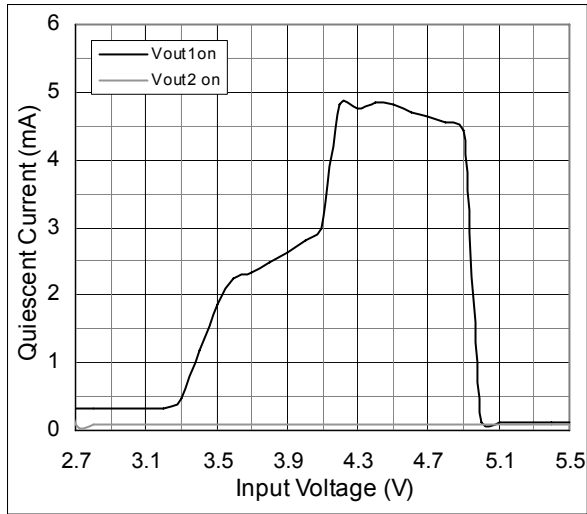
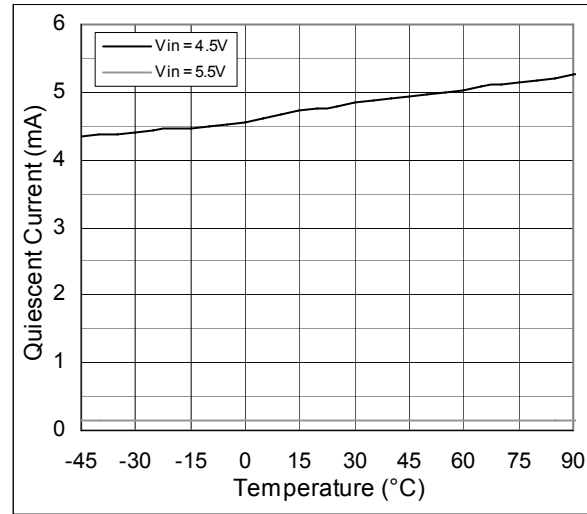

Figure 16. AS1346 I_q vs. V_{IN} , both V_{OUT} enabled



8 Detailed Description

The AS1346, AS1347, AS1348, AS1349 family is a high-efficiency buck converter that uses a constant-frequency current-mode architecture. The device contains two internal MOSFET switches and is available with a fixed output voltage (see [Ordering Information on page 14](#)).

Figure 17. AS1346 - Block Diagram

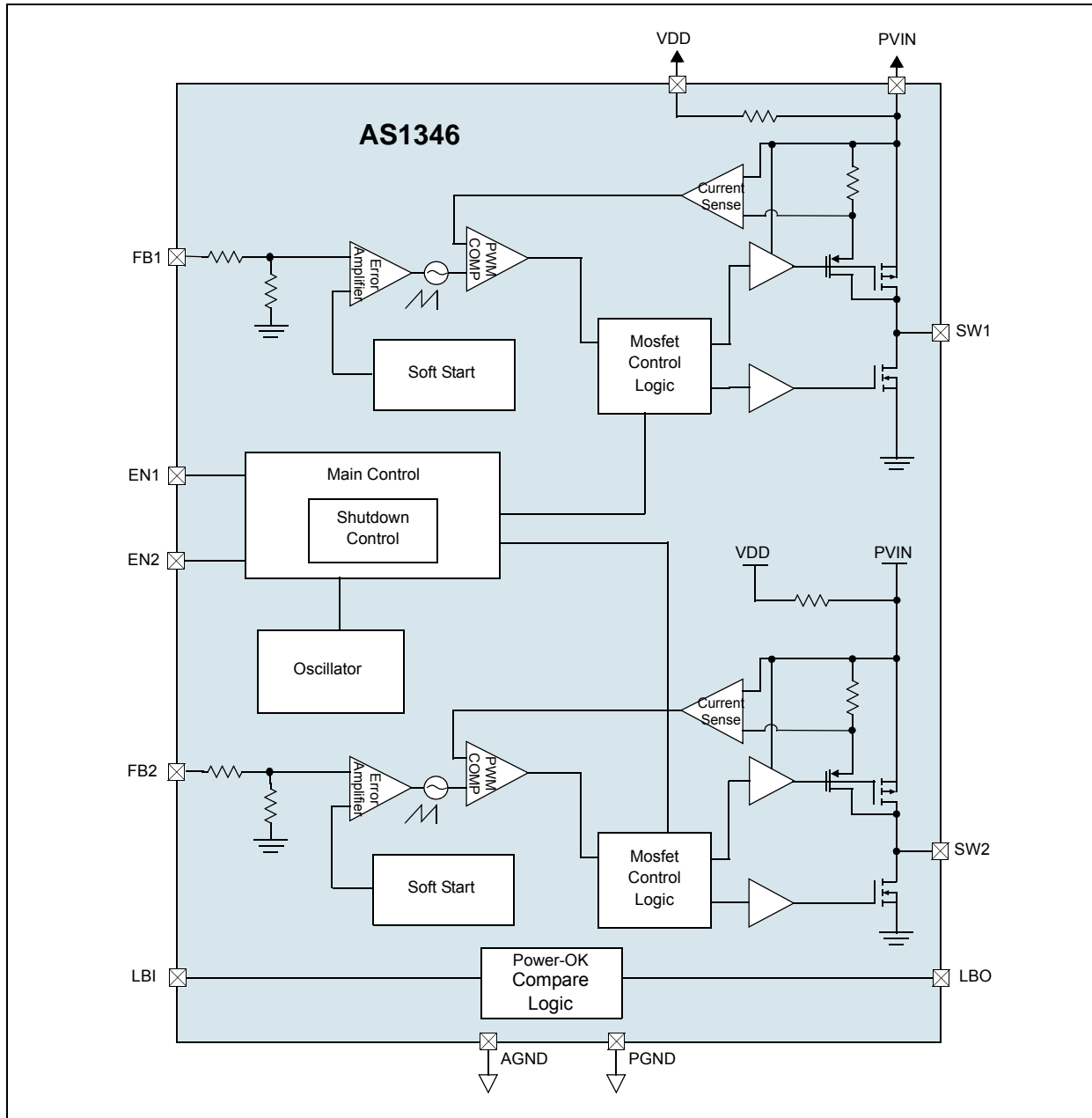

Main Control Loop

During normal operation, the internal top power MOSFET is turned on each cycle when the oscillator sets the RS latch. This switch is turned off when the current comparator resets the RS latch. The peak inductor current (I_{PK}) at which ICOMP resets the RS latch, is controlled by the error amplifier. When I_{LOAD} increases, V_{FB} decreases slightly relative to the internal 0.6V reference, causing the error amplifier's output voltage to increase until the average inductor current matches the new load current.

When the top MOSFET is off, the bottom MOSFET is turned on until the inductor current starts to reverse as indicated by the current reversal comparator, or the next clock cycle begins. The over-voltage detection comparator guards against transient overshoots >7.8% by turning the main switch off and keeping it off until the transient is removed.

Short-Circuit Protection

The short-circuit protection turns off the power switches as long as the short is applied. When the short is removed the device is continuing normal operation.

Dropout Operation

The AS1346, AS1347, AS1348, AS1349 is working with a low input-to-output voltage difference by operating at 100% duty cycle. In this state, the PMOS is always on. This is particularly useful in battery-powered applications with a 3.3V output.

The AS1346, AS1347, AS1348, AS1349 allows the output to follow the input battery voltage as it drops below the regulation voltage. The quiescent current in this state is reduced to a minimal value, which aids in extending battery life. This dropout (100% duty-cycle) operation achieves long battery life by taking full advantage of the entire battery range.

The input voltage requires maintaining regulation and is a function of the output voltage and the load. The difference between the minimum input voltage and the output voltage is called the dropout voltage. The dropout voltage is therefore a function of the on-resistance of the internal PMOS ($R_{DS(ON)PMOS}$) and the inductor resistance (DCR) and this is proportional to the load current.

Note: At low V_{IN} values, the $R_{DS(ON)}$ of the P-channel switch increases (see [Electrical Characteristics on page 4](#)). Therefore, power dissipation should be taken in consideration.

Shutdown

Connecting EN to GND or logic low places the AS1346, AS1347, AS1348, AS1349 in shutdown mode and reduces the supply current to 0.1µA. In shutdown the control circuitry and the internal NMOS and PMOS turn off and SW becomes high impedance disconnecting the input from the output. The output capacitance and load current determine the voltage decay rate. For normal operation connect EN to V_{IN} or logic high.

Note: Pin EN should not be left floating.

Power-OK and Low-Battery-Detect Functionality

LBO goes low in startup mode as well as during normal operation if:

- The voltage at the LBI pin is below LBI threshold (1.2V). This can be used to monitor the battery voltage.
- LBI pin is connected to GND and V_{OUT1} is below 92.5% of its nominal value. LBO works as a power-OK signal in this case.

The LBI pin can be connected to a resistive-divider to monitor a particular definable voltage and compare it with a 1.2V internal reference. If LBI is connected to GND (see [Figure 1 on page 1](#)) an internal resistive-divider is activated and connected to the output. Therefore, the Power-OK functionality can be realised with no additional external components.

The Power-OK feature is not active during shutdown. To obtain a logic-level output, connect a pull-up resistor from pin LBO to pin V_{OUT} or V_{DD} . Larger values for this resistor will help to minimize current consumption; a 100kΩ resistor is perfect for most applications (see [Figure 18 on page 11](#)).

For the circuit shown in the left of [Figure 18 on page 11](#), the input bias current into LBI is very low, permitting large-value resistor-divider networks while maintaining accuracy. Place the resistor-divider network as close to the device as possible. Use a defined resistor for R_2 and then calculate R_1 as:

$$R_1 = R_2 \cdot \left(\frac{V_{IN}}{V_{LBI}} - 1 \right) \quad (EQ 1)$$

Where:

V_{LBI} (the internal sense reference voltage) is 1.2V.

In case of the LBI pin is connected to GND, an internal resistor-divider network is activated and compares the output voltage with a 92.5% voltage threshold (see AS1346 - Typical Application Diagram with POK Function on page 1). For this particular Power-OK application, no external resistive components (R1 and R2) are necessary.

Figure 18. Typical Application Diagram with adjustable Battery Monitoring

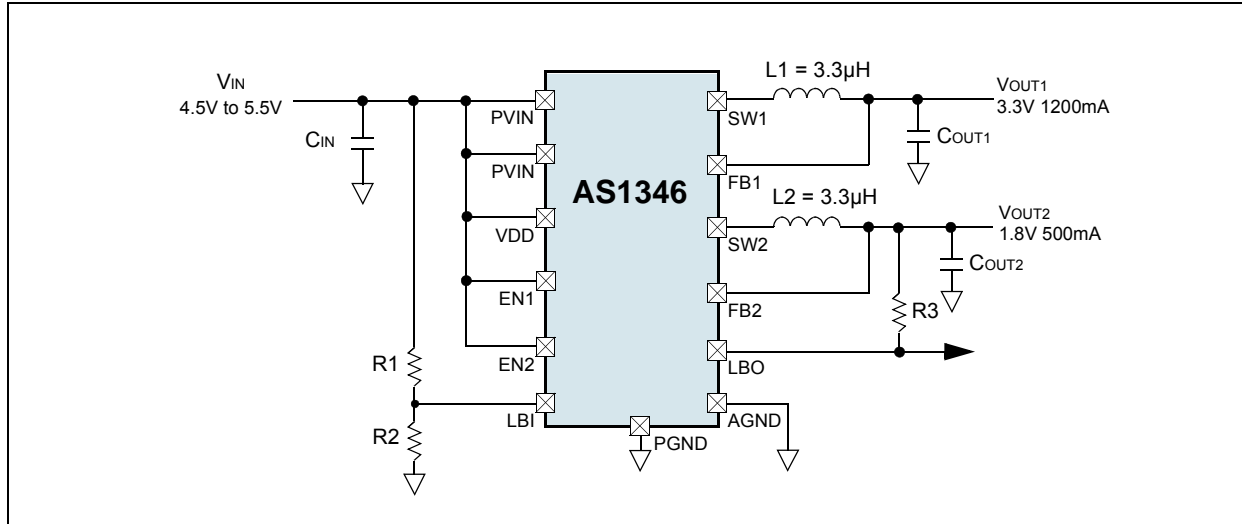

Thermal Shutdown

Due to its high-efficiency design, the AS1346 will not dissipate much heat in most applications. However, in applications where the AS1346 is running at high ambient temperature, uses a low supply voltage, and runs with high duty cycles (such as in dropout) the heat dissipated may exceed the maximum junction temperature of the device.

As soon as the junction temperature reaches approximately 150°C the AS1346 goes in thermal shutdown. In this mode the internal PMOS & NMOS switch are turned off. The device will power up again, as soon as the temperature falls below +140°C again.

9 Application Information

Component Selection

Only three power components are required to complete the design of the buck converter. For the adjustable LBI two external resistors are needed.

Inductor Selection

For the external inductor, a 3.3 μ H inductor is recommended. Minimum inductor size is dependant on the desired efficiency and output current. Inductors with low core losses and small DCR at 2MHz are recommended.

Table 5. Recommended Inductors

Part Number	L	DCR	Current Rating	Dimensions (L/W/T)	Manufacturer
LPS4018-332ML	3.3 μ H	80m Ω	2.4A	3.9x3.9x1.7mm	Coilcraft www.coilcraft.com

Capacitor Selection

A 10 μ F capacitor is recommended for C_{IN} as well as a 10 μ F for C_{OUT}. Small-sized X5R or X7R ceramic capacitors are recommended as they retain capacitance over wide ranges of voltages and temperatures.

Input and Output Capacitor Selection

Low ESR input capacitors reduce input switching noise and reduce the peak current drawn from the battery. Also low ESR capacitors should be used to minimize V_{OUT} ripple. Multi-layer ceramic capacitors are recommended since they have extremely low ESR and are available in small footprints.

For input decoupling the ceramic capacitor should be located as close to the device as practical. A 22 μ F input capacitor is sufficient for most applications. Larger values may be used without limitations.

A 2.2 μ F to 10 μ F output ceramic capacitor is sufficient for most applications. Larger values up to 22 μ F may be used to obtain extremely low output voltage ripple and improve transient response.

Table 6. Recommended Input and Output Capacitor

	Part Number	C	TC Code	Rated Voltage	Size	Manufacturer
C _{IN}	GRM31CR60J476ME19	47 μ F	X5R	6.3V	1206	Murata www.murata.com
C _{OUT1} , C _{OUT2}	GRM32DR71E106KA12	10 μ F	X7R	25V	1210	

10 Package Drawings and Markings

The devices are available in a 12-Pin TDFN 3x3mm package.

Figure 19. 12-Pin TDFN 3x3mm Package

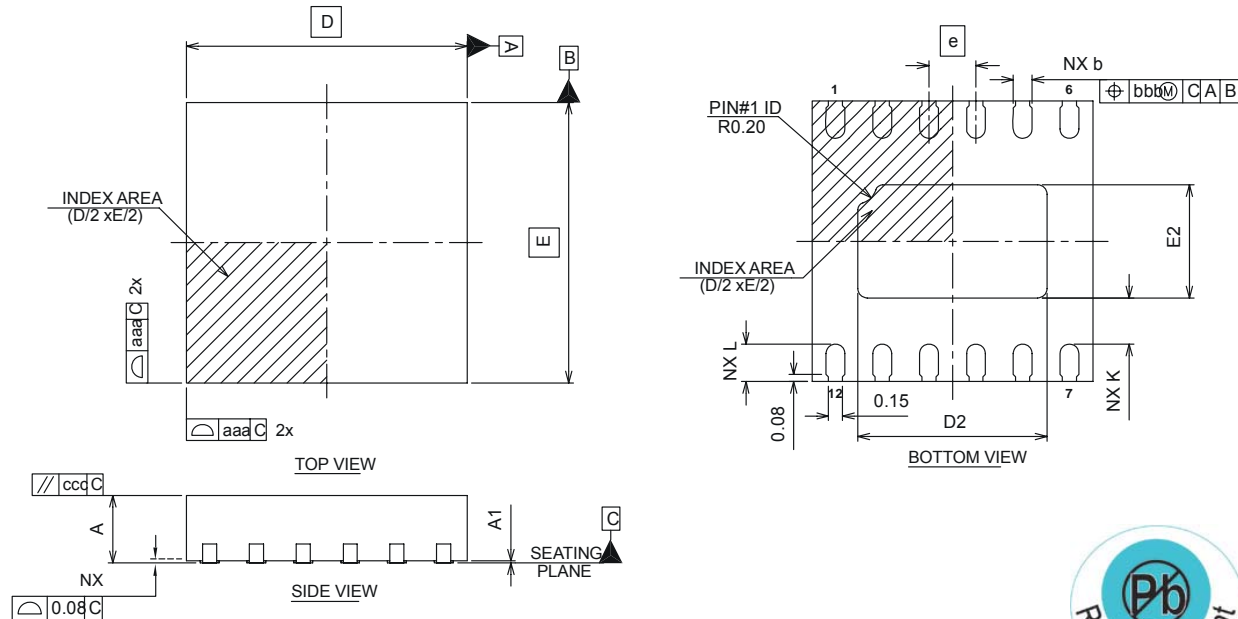

Symbol	Min	Typ	Max	Notes
A	0.70	0.75	0.80	1, 2
A1	0.00	0.02	0.05	1, 2
aaa		0.10		1, 2
bbb		0.10		1, 2
ccc		0.10		1, 2

Symbol	Min	Typ	Max	Notes
D BSC		3.00		1, 2
E BSC		3.00		1, 2
D2	1.87	2.02	2.12	1, 2
E2	1.06	1.21	1.31	1, 2
L	0.30	0.40	0.50	1, 2
θ	0°		14°	1, 2
k	0.20			1, 2
b	0.15	0.20	0.25	1, 2, 5
e		0.5		
N		12		1, 2
ND		6		1, 2, 5

Notes:

- Figure 19 is shown for illustration only.
- All dimensions are in millimeters; angles in degrees.
- N is the total number of terminals.
- The terminal #1 identifier and terminal numbering convention shall conform to JEDEC 95-1, SPP-012. Details of terminal #1 identifier are optional, but must be located within the zone indicated. The terminal #1 identifier may be either a mold or marked feature.
- Dimension b applies to metallized terminal and is measured between 0.15mm and 0.30mm from the terminal tip.
- ND refers to the maximum number of terminals on side D.
- Unilateral coplanarity zone applies to the exposed heat sink slug as well as the terminals

11 Ordering Information

The device is available as the standard products listed below.

Table 7. Ordering Information

Ordering Code	Marking	Channel	Vout	Iout	Description	Delivery Form	Package
AS1346-BTDT-3318	ASSL	OUT1	3.3V	1.2A	Dual Step-Down Converter with Battery Monitoring	Tape and Reel	12-Pin TDFN 3x3mm
		OUT2	1.8V	0.5A			
AS1347-BTDT-xyy ¹	tbd	OUT1	xx	0.5A	Dual Step-Down Converter with Battery Monitoring	Tape and Reel	12-Pin TDFN 3x3mm
		OUT2	yy	0.5A			
AS1348-BTDT-xyy ¹	tbd	OUT1	xx	0.5A	Dual Step-Down Converter with Battery Monitoring	Tape and Reel	12-Pin TDFN 3x3mm
		OUT2	yy	0.95A			
AS1349-BTDT-xyy ¹	tbd	OUT1	xx	1.2A	Dual Step-Down Converter with Battery Monitoring	Tape and Reel	12-Pin TDFN 3x3mm
		OUT2	yy	1.2A			

1. Non-standard devices from 1.2V to 3.6V are available in 100mV steps. For more information and inquiries contact <http://www.austriamicrosystems.com/contact>

Receive samples within **2 weeks** for any non standard output voltage variant!

Note: All products are RoHS compliant.

Buy our products or get free samples online at ICdirect: <http://www.austriamicrosystems.com/ICdirect>

Technical Support is found at <http://www.austriamicrosystems.com/Technical-Support>

For further information and requests, please contact us <mailto:sales@austriamicrosystems.com> or find your local distributor at <http://www.austriamicrosystems.com/distributor>

Copyrights

Copyright © 1997-2010, austriamicrosystems AG, Tobelbaderstrasse 30, 8141 Unterpremstaetten, Austria-Europe. Trademarks Registered ®. All rights reserved. The material herein may not be reproduced, adapted, merged, translated, stored, or used without the prior written consent of the copyright owner.

All products and companies mentioned are trademarks or registered trademarks of their respective companies.

Disclaimer

Devices sold by austriamicrosystems AG are covered by the warranty and patent indemnification provisions appearing in its Term of Sale. austriamicrosystems AG makes no warranty, express, statutory, implied, or by description regarding the information set forth herein or regarding the freedom of the described devices from patent infringement. austriamicrosystems AG reserves the right to change specifications and prices at any time and without notice. Therefore, prior to designing this product into a system, it is necessary to check with austriamicrosystems AG for current information. This product is intended for use in normal commercial applications. Applications requiring extended temperature range, unusual environmental requirements, or high reliability applications, such as military, medical life-support or life-sustaining equipment are specifically not recommended without additional processing by austriamicrosystems AG for each application. For shipments of less than 100 parts the manufacturing flow might show deviations from the standard production flow, such as test flow or test location.

The information furnished here by austriamicrosystems AG is believed to be correct and accurate. However, austriamicrosystems AG shall not be liable to recipient or any third party for any damages, including but not limited to personal injury, property damage, loss of profits, loss of use, interruption of business or indirect, special, incidental or consequential damages, of any kind, in connection with or arising out of the furnishing, performance or use of the technical data herein. No obligation or liability to recipient or any third party shall arise or flow out of austriamicrosystems AG rendering of technical or other services.



Contact Information

Headquarters

austriamicrosystems AG
Tobelbaderstrasse 30
A-8141 Unterpremstaetten, Austria

Tel: +43 (0) 3136 500 0
Fax: +43 (0) 3136 525 01

For Sales Offices, Distributors and Representatives, please visit:

<http://www.austriamicrosystems.com/contact>