

# MAX14634

## Ultra-Low On-Resistance and Compact Bidirectional Battery Switch

### General Description

The MAX14634 bidirectional battery switch features reverse blocking capability to isolate the battery from the system. The internal switch features ultra-low  $7\text{m}\Omega$  (typ) on-resistance and operates from a +2.3V to +5.5V input voltage range, making this device ideal as a battery-disconnect switch for high-capacity battery applications. The slew-rate controlled switch is also ideal for a large load capacitor as well as high-current load switching applications.

The device is available in an ultra-small 12-bump (1.3mm x 1.7mm, 0.4mm pitch) WLP package. The tiny, low-profile package is suitable for space-limited portable device applications. The device operates over the  $-40^{\circ}\text{C}$  to  $+85^{\circ}\text{C}$  extended temperature range.

### Applications

Tablet PC Battery Switches  
 Smartphone Battery Switches  
 Battery Isolators

### Benefits and Features

- ◆ Provides Efficient System Battery Switch
  - ◇ Integrated FET for Bidirectional Blocking
  - ◇ Ultra-Low  $7\text{m}\Omega$  (typ)  $R_{\text{ON}}$
  - ◇ Wide Input Voltage Range: +2.3V to +5.5V
  - ◇ Low Quiescent Current
- ◆ Saves Space
  - ◇ Integrated Pulldown and Logic Buffer Circuits
  - ◇ 12-Bump, 1.3mm x 1.7mm, 0.4mm Pitch WLP Package

*Ordering Information* appears at end of data sheet.

For related parts and recommended products to use with this part, refer to [www.maximintegrated.com/MAX14634.related](http://www.maximintegrated.com/MAX14634.related).

### Typical Operating Circuit

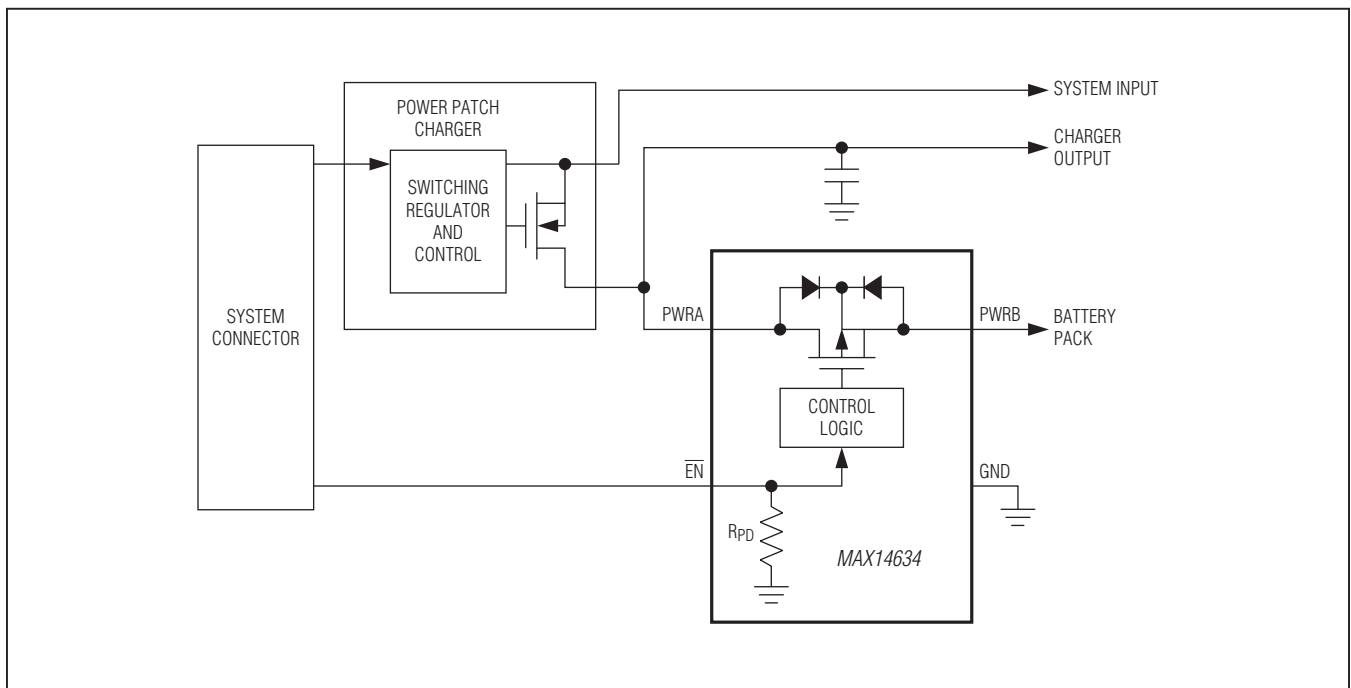

# MAX14634

## Ultra-Low On-Resistance and Compact Bidirectional Battery Switch

### ABSOLUTE MAXIMUM RATINGS

(All voltages referenced to GND.)

PWRA, PWRB,  $\overline{EN}$  ..... -0.3V to +6V  
 Current into PWRA, PWRB .....  $\pm 7A$   
 Continuous Power Dissipation ( $T_A = +70^\circ C$ )  
 WLP (derate 13.7mW/ $^\circ C$  above +70 $^\circ C$ )..... 1096mW

Operating Temperature Range ..... -40 $^\circ C$  to +85 $^\circ C$   
 Maximum Junction Temperature..... +150 $^\circ C$   
 Storage Temperature Range..... -65 $^\circ C$  to +150 $^\circ C$   
 Soldering Temperature (reflow) ..... +260 $^\circ C$

Stresses beyond those listed under "Absolute Maximum Ratings" may cause permanent damage to the device. These are stress ratings only, and functional operation of the device at these or any other conditions beyond those indicated in the operational sections of the specifications is not implied. Exposure to absolute maximum rating conditions for extended periods may affect device reliability.

### PACKAGE THERMAL CHARACTERISTICS (Note 1)

WLP

Junction-to-Ambient Thermal Resistance ( $\theta_{JA}$ ) ..... 73 $^\circ C/W$

**Note 1:** Package thermal resistances were obtained using the method described in JEDEC specification JESD51-7, using a four-layer board. For detailed information on package thermal considerations, refer to [www.maximintegrated.com/thermal-tutorial](http://www.maximintegrated.com/thermal-tutorial).

### ELECTRICAL CHARACTERISTICS

( $V_{PWRA}, V_{PWRB} = 2.3V$  to  $5.5V$ ;  $T_A = -40^\circ C$  to  $+85^\circ C$ , unless otherwise noted. Typical values are at  $V_{PWRA}, V_{PWRB} = 4.2V$ ;  $C_{PWRA}, C_{PWRB} = 0.1\mu F$ ;  $T_A = +25^\circ C$ .) (Note 2)

PARAMETER	SYMBOL	CONDITIONS	MIN	TYP	MAX	UNITS
<b>SUPPLY OPERATION</b>						
Operating Voltage	$V_{PWRA}$ $V_{PWRB}$		2.3		5.5	V
Quiescent Current	$I_{PWRA}$ $I_{PWRB}$	$V_{\overline{EN}} = 0.4V$ , no load			1	$\mu A$
Transient Supply Current		$\overline{EN}$ from high to low or low to high		30		$\mu A$
Shutdown Current	$I_{SHDN}$	$V_{\overline{EN}} = 5.5V$ , ( $V_{PWRA} = 5.5V$ , $V_{PWRB} =$ open) or ( $V_{PWRB} = 5.5V$ , $V_{PWRA} =$ open)			1	$\mu A$
<b>INTERNAL FET</b>						
On-Resistance Between PWRA and PWRB	$R_{ON}$	$T_A = +25^\circ C$ , $I_{LOAD} = 100mA$	$V_{PWRA}, V_{PWRB} = 2.3V$	8	13	m $\Omega$
			$V_{PWRA}, V_{PWRB} = 3.3V$	7	10	
<b><math>\overline{EN}</math> INPUT</b>						
$\overline{EN}$ Input Logic-High Voltage	$V_{IH}$		1.6			V
$\overline{EN}$ Input Logic-Low Voltage	$V_{IL}$				0.4	V
$\overline{EN}$ Internal Pulldown Resistor	RPD			500	700	k $\Omega$
<b>DYNAMIC</b>						
Turn-On Time	$t_{ON}$	Time from $\overline{EN}$ high-to-low signal to $V_{PWRB/A} = 90\%$ of $V_{PWRA/B}$		3		ms
Turn-Off Time	$t_{OFF}$	Time from $\overline{EN}$ low-to-high signal to $V_{PWRB/A} = 10\%$ of $V_{PWRA/B}$ , $R_{LOAD} = 100\Omega$		3		ms

**Note 2:** All devices are 100% production tested at  $T_A = +25^\circ C$ . Specifications over the operating temperature range are guaranteed by design.

# MAX14634

## Ultra-Low On-Resistance and Compact Bidirectional Battery Switch

### Typical Operating Characteristics

( $T_A = +25^\circ\text{C}$ , unless otherwise noted.)

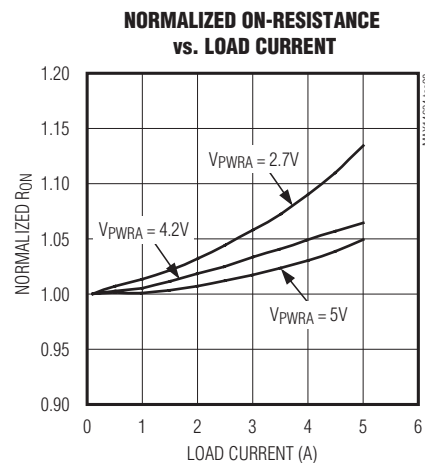
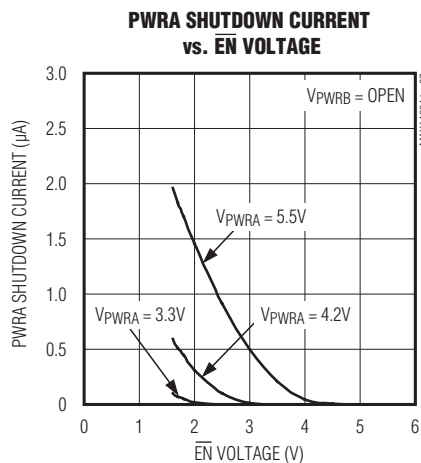
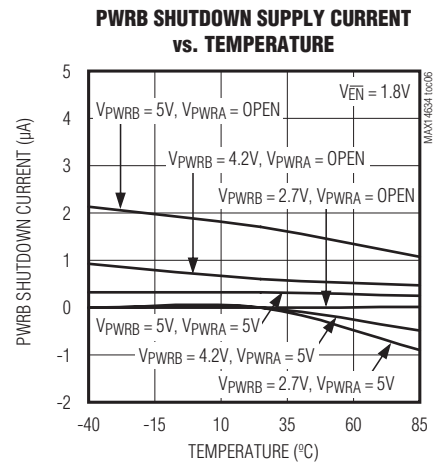
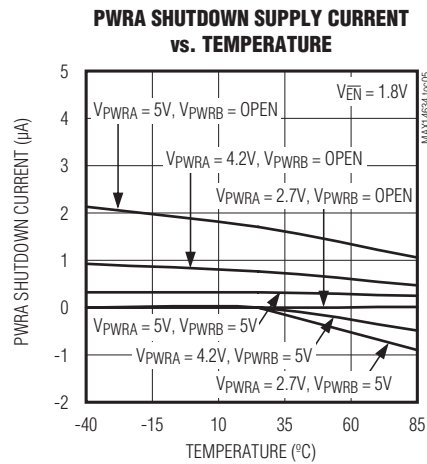
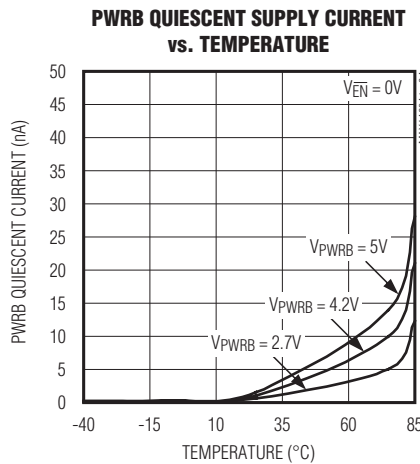
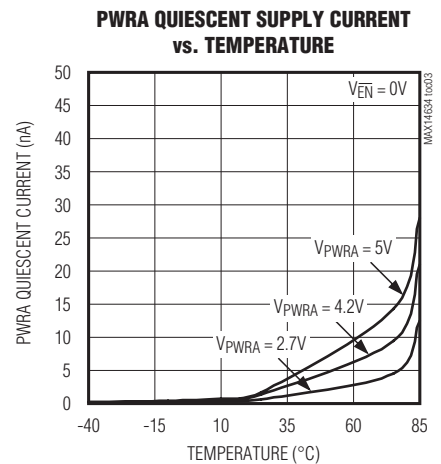
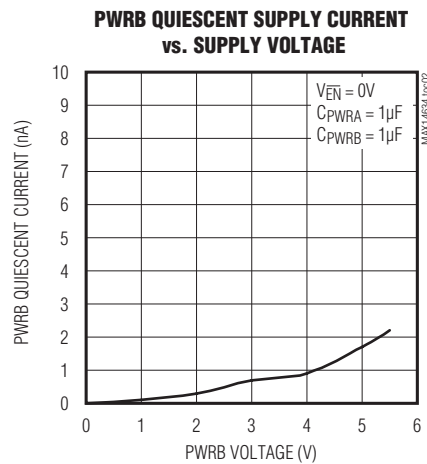
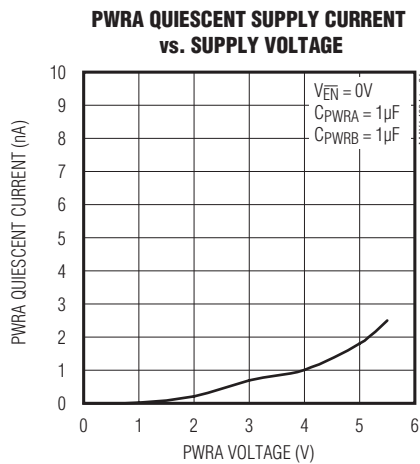

# MAX14634

## Ultra-Low On-Resistance and Compact Bidirectional Battery Switch

### Typical Operating Characteristics (continued)

( $T_A = +25^\circ\text{C}$ , unless otherwise noted.)

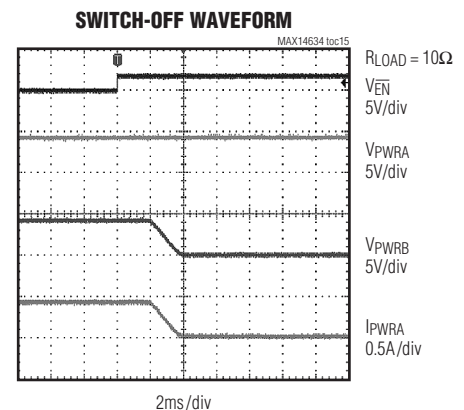
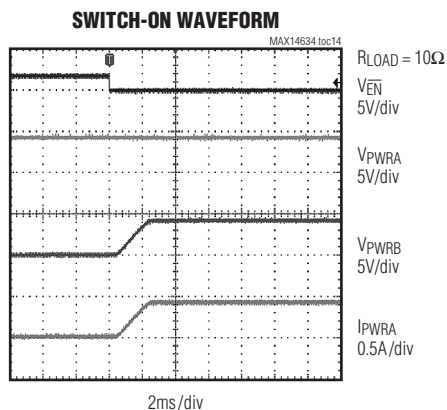
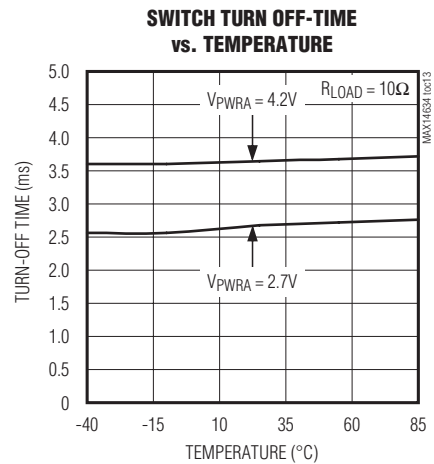
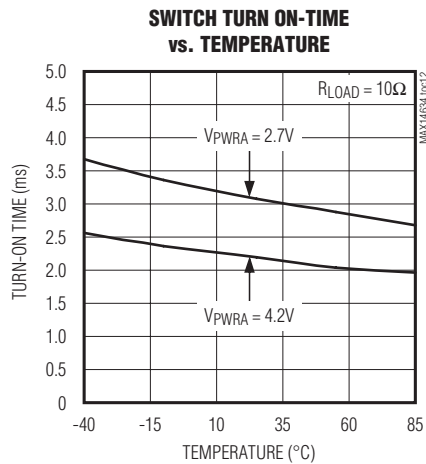
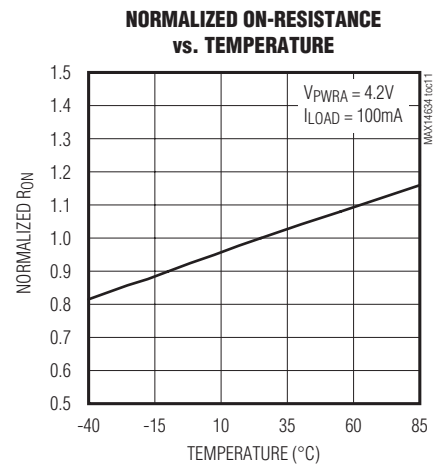
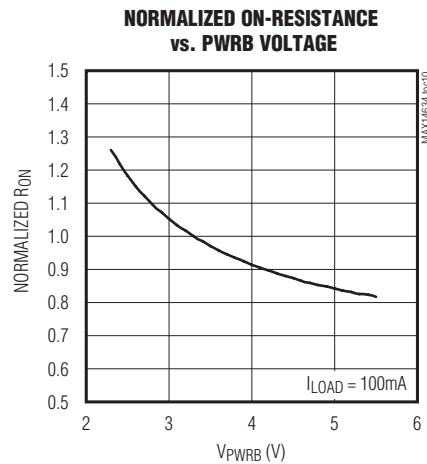
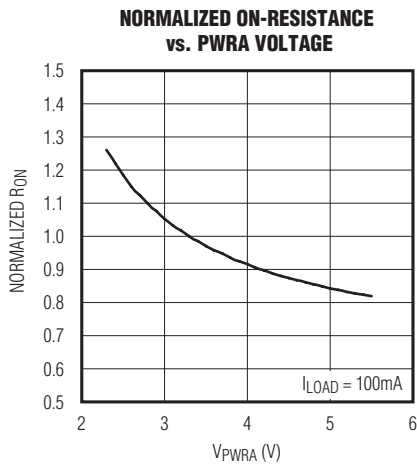

# MAX14634

## Ultra-Low On-Resistance and Compact Bidirectional Battery Switch

### *Bump Configuration*

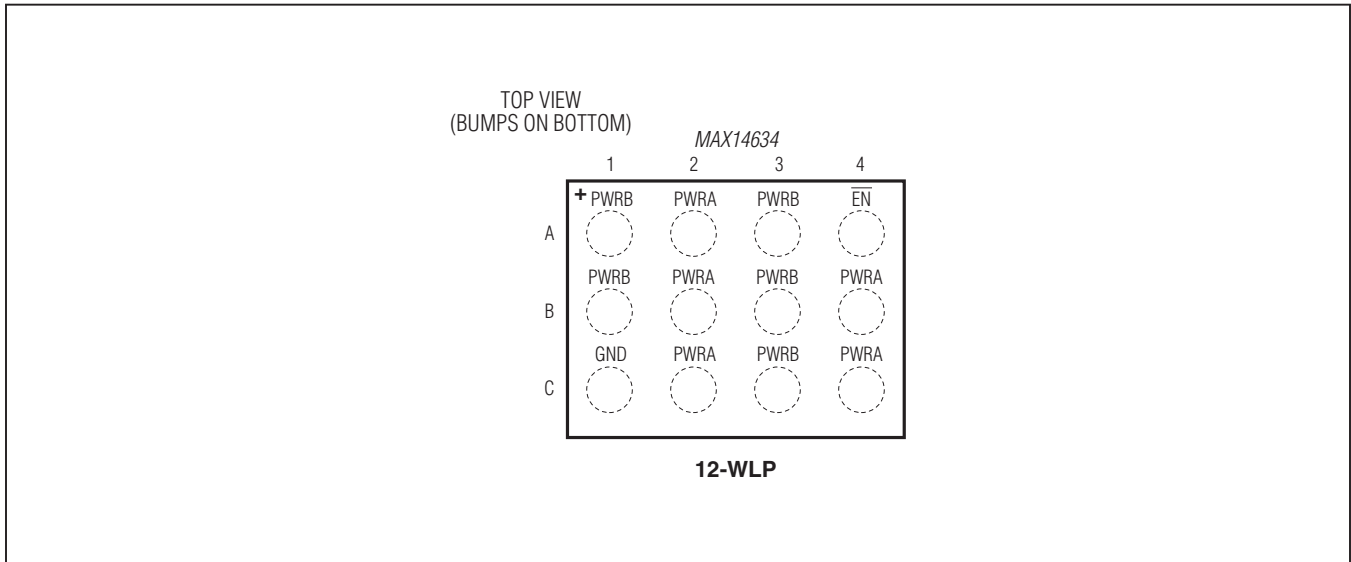

### *Bump Description*

BUMP	NAME	FUNCTION
A1, A3, B1, B3, C3	PWRB	Power I/O
A2, B2, B4, C2, C4	PWRA	Power I/O
A4	$\overline{\text{EN}}$	Active-Low Enable Input. Drive $\overline{\text{EN}}$ low to turn on the switch.
C1	GND	Ground

# MAX14634

## Ultra-Low On-Resistance and Compact Bidirectional Battery Switch

### Functional Diagram

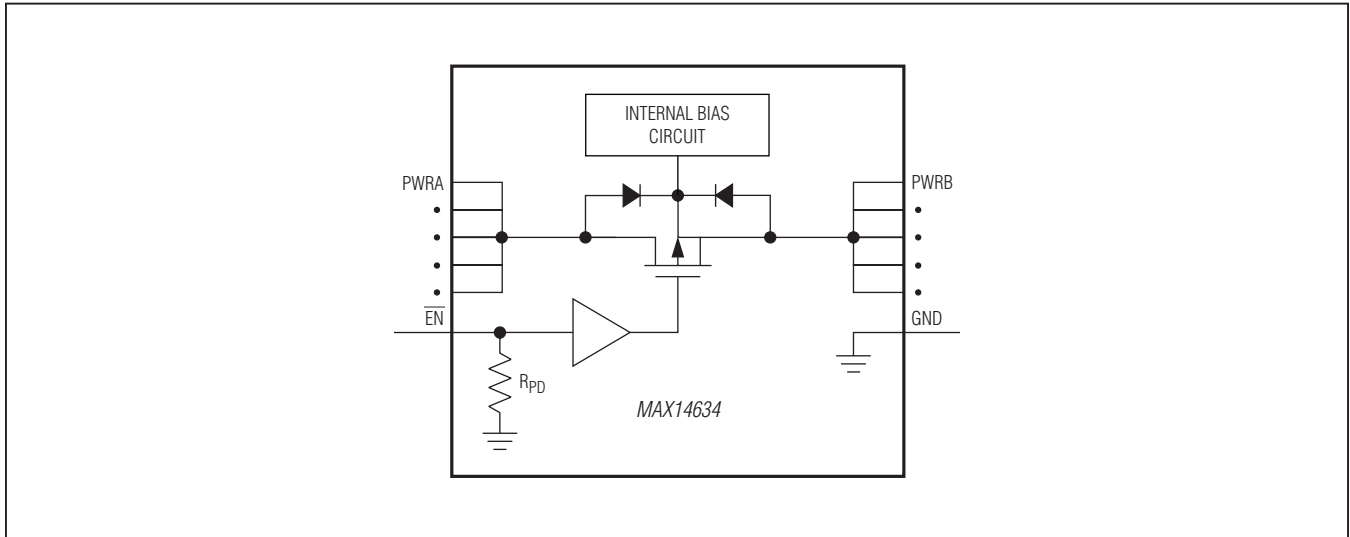

### Detailed Description

The MAX14634 is a bidirectional switch with ultra-low 7mΩ (typ) on-resistance and reverse-current blocking capability. The device has low quiescent current and operates from a +2.3V to +5.5V input voltage range, making this device ideal as a battery-disconnect switch for high-capacity battery applications. The slew-rate controlled switch is also ideal for a large load capacitor as well as high-current load switching applications.

#### Reverse-Current Blocking

The bidirectional FET switch prevents current flowing from either power input to the other when the switch is disabled.

#### EN Input

The switch position is controlled by an  $\overline{\text{EN}}$  active-low logic input. The switch is on when  $\overline{\text{EN}}$  is logic-low and off when  $\overline{\text{EN}}$  is logic-high.  $\overline{\text{EN}}$  is internally pulled down to ground by  $R_{PD}$ .

### Ordering Information

PART	TEMP RANGE	TOP MARK	PIN-PACKAGE
MAX14634EWC+T	-40°C to +85°C	ACO	12 WLP

+ Denotes a lead(Pb)-free/RoHS-compliant package.  
T = Tape and reel

### Chip Information

PROCESS: BiCMOS

### Package Information

For the latest package outline information and land patterns (footprints), go to [www.maximintegrated.com/packages](http://www.maximintegrated.com/packages). Note that a "+", "#", or "-" in the package code indicates RoHS status only. Package drawings may show a different suffix character, but the drawing pertains to the package regardless of RoHS status.

PACKAGE TYPE	PACKAGE CODE	OUTLINE NO.	LAND PATTERN NO.
12 WLP	W121F1+1	<a href="#">21-0449</a>	Refer to <a href="#">Application Note 1891</a>

# MAX14634

## Ultra-Low On-Resistance and Compact Bidirectional Battery Switch

### Revision History

REVISION NUMBER	REVISION DATE	DESCRIPTION	PAGES CHANGED
0	5/12	Initial release	—
1	1/13	Updated Absolute Maximum Ratings section	2



Maxim Integrated cannot assume responsibility for use of any circuitry other than circuitry entirely embodied in a Maxim Integrated product. No circuit patent licenses are implied. Maxim Integrated reserves the right to change the circuitry and specifications without notice at any time. The parametric values (min and max limits) shown in the Electrical Characteristics table are guaranteed. Other parametric values quoted in this data sheet are provided for guidance.

**Maxim Integrated 160 Rio Robles, San Jose, CA 95134 USA 1-408-601-1000**

7