

BW7386

Accuracy Constant Current LED Driver



FEATURES

- Accuracy Constant Current
- Low BOM Cost
- Current Mode/Fixed Frequency Control
- Gate Output Voltage Clamp
- LED Open Protection(OVP)
- Over Current Protection (OCP)
- 300mA Driving Capability for OUT Pin

APPLICATIONS

- E 26/27, T5/T8 LED Lamp
- O thers LED Lighting Applications

DESCRIPTION

The BW7386 is a highly-integrated, low startup current, current mode, and fixed switching frequency PWM controller. These functions enable the LED driver to easily meet the accuracy average LED current requirements. The integrated functions also include the LED open protection, and internal over temperature protection. The COMP pin controls the duty by connected an RC compensation network to ground and forming the closed loop feedback control. To protect the external power MOSFET from being damaged by supply over voltage, the BW7386 OU T pin voltage is clamped to about 17V. The BW7386 improves the performance and reduces the cost of the LED driver. It is a 6-pin SOT-26 package.

ORDER INFORMATION

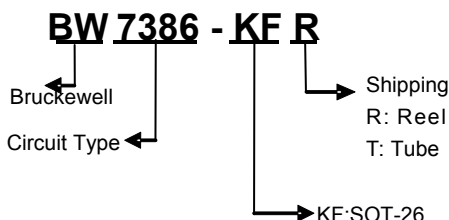

PIN CONFIGURATIONS (TOP VIEW)

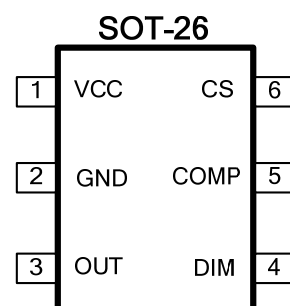

BW7386

Accuracy Constant Current LED Driver



PIN DESCRIPTIONS

Pin Name	Pin Description
VCC	Power supply pin
GND	Ground pin
OUT	The output driver for driving the external MOSFET
DIM	Dimming Control Pin by Input a DC Voltage
COMP	Feedback compensation network
CS	Current sense pin, connect to sense the MOSFET current

TYPICAL APPLICATION CIRCUITS

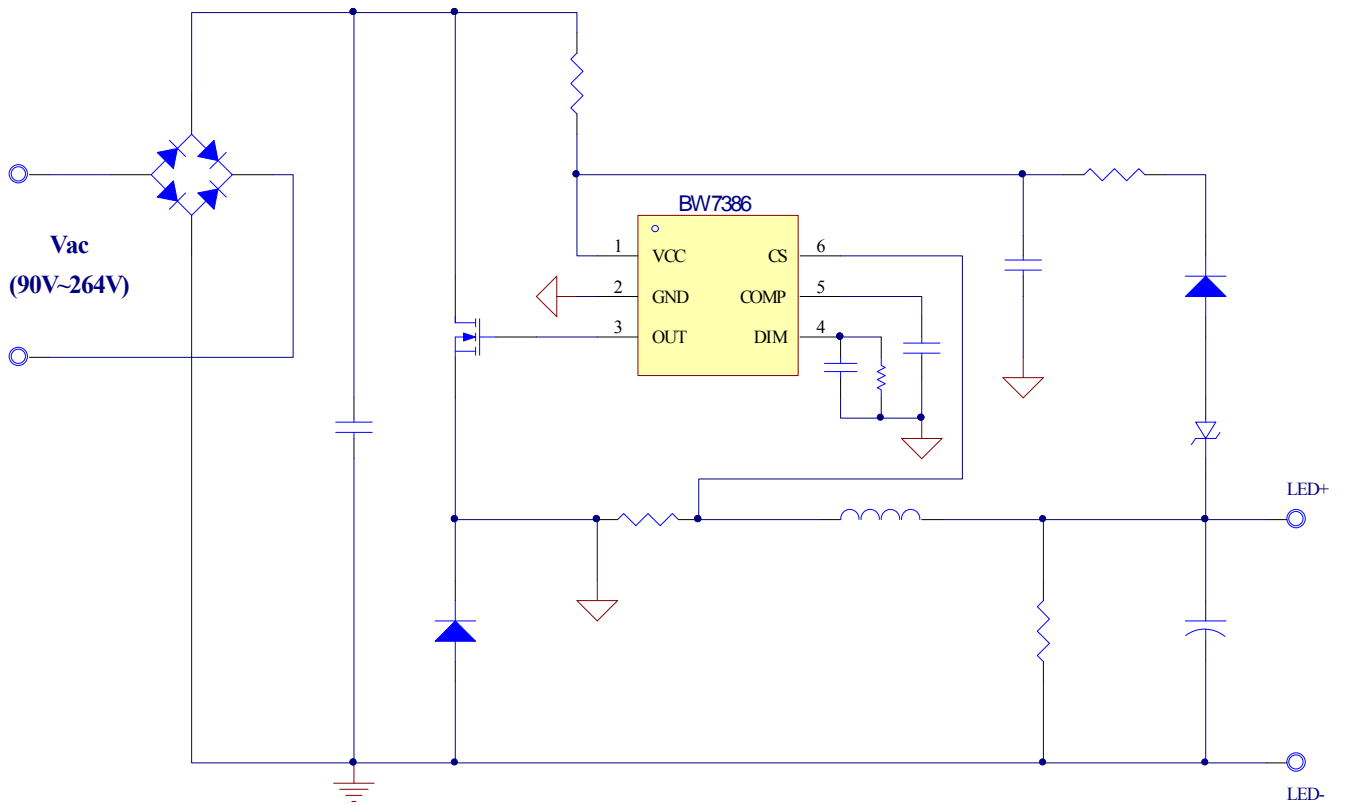

ABSOLUTE MAXIMUM RATINGS (Note 1)

Parameter	Symbol	Range	Unit
Power supply pin	V_{DD}	30	V
DIM voltage to GND	V_{DIM}	-0.3 to 7	V
CS voltage to GND	V_{CS}	-0.3 to 7	V
OUT voltage to GND	V_{OUT}	15	V
Maximum junction temperature	T_J	150	°C
Storage temperature rang	T_{STG}	-65 to +150	°C
Lead temperature (Soldering 5 sec)	T_{LEAD}	260	°C
Power dissipation @ $T_A=25$ °C	P_D	300	mW
Thermal resistance junction to ambient (Note 2)	Θ_{JA}	333	°C/W
Thermal Resistance	Θ_{JC}	106.6	°C/W
ESD rating, Human body mode (Note 3)	V_{ESD}	2	kV
ESD rating, machine mode (Note 3)	V_{ESD}	200	V

RECOMMENDED OPERATING CONDITIONS (Note 4)

Parameter	Symbol	Operation Conditions	Unit
Supply voltage	V_{DD}	26	V
Operating junction temperature range	T_J	150	°C
Operating ambient temperature range	T_{OPA}	-20 to +85	°C

Note 1: Stresses listed as the above "Absolute Maximum Ratings" may cause permanent damage to the device. These are for stress ratings. Functional operation of the device at these or any other conditions beyond those indicated in the operational sections of the specifications is not implied. Exposure to absolute maximum rating conditions for extended periods may remain possibility to affect device reliability.

Note 2: Thermal Resistance is specified with the component mounted on a low effective thermal conductivity test board in free air at $T_A=25$ °C.

Note 3: Devices are ESD sensitive. Handling precaution recommended.

Note 4: The device is not guaranteed to function outside its operating conditions.

BLOCK DIAGRAM

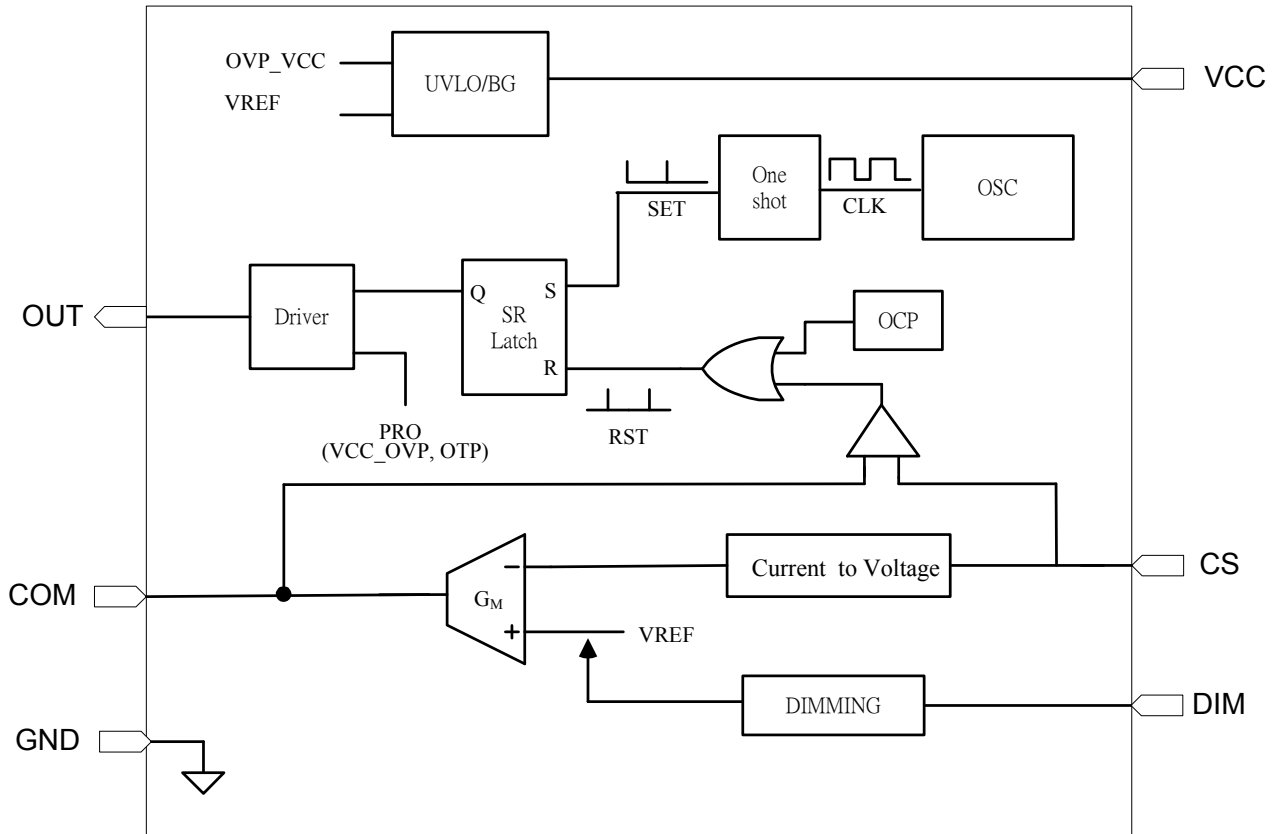

Block Diagram

ELECTRICAL CHARACTERISTICS

$V_{CC}=15V$, $T_A=25^{\circ}C$, unless otherwise specified.

Parameter	Symbol	Condition	Min	Typ	Max	Unit
SUPPLY VOLTAGE						
Startup Current	$V_{DD(ST)}$	$V_{CC}=UVLO$ on -1V		8		μA
Operating Current	V_{COMP}	With 1nF load on OUT pin		1.5	2.5	mA
Operating Current	I_{OPA}	With 1nF load on OUT pin Protection Tripped (OCP, OVP, SCP,OTP)	1	.2	1.8	mA
UVLO(off)			7	8	8	V
UVLO(on)			17	18	19	V
OVP Level on VCC Pin	OVP		26	28	30	V
VOLTAGE FEEDBACK						
Feedback Reference Voltage	V_{FB}		0.194	0.2	0.206	V
Tran-Conductance				120		μS
Output Sink Current	I_{O-sink}			12		μA
Output Source Current	$I_{O-source}$			12		μA
CURRENT SENSING						
Input Over Voltage Protection	F_{OSC}			0.8		V
Open Loop Voltage, CS Pin Open			5			V
Leading-Edge Blanking Time			4	10		nS
Delay to Output			1	00		nS
SWITCHING FREQUENCY						
Switching Frequency			42	45	48	KHz
Maximum Duty			90			%
Frequency Jitter Range				+/-6		%
Temp. Stability		$-40^{\circ}C \sim 125^{\circ}C$			6	%
Voltage Stability		$V_{CC}=11V \sim 25V$			1	%
GATE DRIVER OUTPUT						
Rising Time		Load Capacitance = 1000pF		160		nS
Falling Time		Load Capacitance = 1000pF		80		nS
VGATE-Clamp		$V_{CC}=25V$		17	19	V

BW7386

Accuracy Constant Current LED Driver



DIM INPUT SECTION						
Saturation Threshold Voltage			3.0			V
Linear Dimming Range			0.6		3.0	V
Current Source			270	300	330	uA
Thermal Section						
Thermal Shutdown	TSD			150		°C

APPLICATION INFORMATION

Start-up Current

The typical start-up current is around 8uA. Very low start-up current allows the PWM controller to increase the value of start-up resistor and then reduce the power dissipation on it.

UVLO(Under Voltage Lockout)

A hysteresis UVLO comparator is implemented in BW7386 then the turn-on and turn-off thresholds level are fixed at 18V and 8V respectively. This hysteresis shown in Fig.1 ensures that the start-up capacitor will be adequate to supply the chip during start-up. For quickly startup the LED driver, the start-up resistor should be matched with the startup capacitor. Due to the low UVLO on level, so the turn-on delay time will also never greater than the general PWM IC.

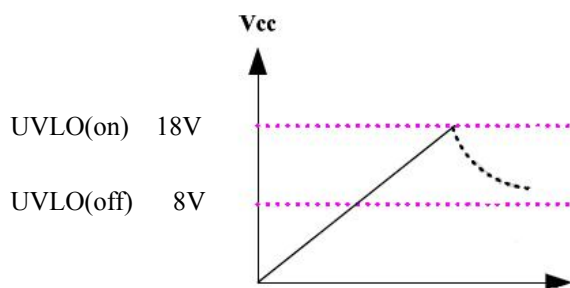

Fig. 1

Oscillator

The maximum duty-cycle of internal oscillator is up to 90% for driving high LED voltage string. The frequency of the oscillator is fixed to 45KHZ by internal setting.

LEB(Leading-Edge Blanking)

Each time the power MOSFET is switched on, a turn-on spike will inevitably occur at the sense resistor. To avoid fault trigger, a 410ns leading-edge blanking time is built in. Conventional RC filtering can therefore be omitted. During this blanking period, the current-limit comparator is disabled and can not switch off the gate driver.

OCP(Over Current Protection)

The BW7386 has an over current protection function on CS pin. An internal circuit detects the current level, when the current is larger than a threshold level, the gate output will keep on low level. Then VCC decreases below UVLO off level, the controller resets again.

OVP (Over Voltage Protection) on VCC

To prevent the LED driver from being damaged, the BW7386 is implemented an OVP function on VCC. When the VCC voltage is higher than the OVP threshold voltage 28V, the output gate driver circuit will be shut down immediately to stop the switching of power MOSFET. The VCC pin OVP function is an auto recovery type protection (latch off type optional). If the OVP condition happens, the pulses will be stopped and never recovery unless the VCC pin voltage is down to the UVLO off level. The BW7386 is working in an auto-recovery mode as shown in Fig. 2.

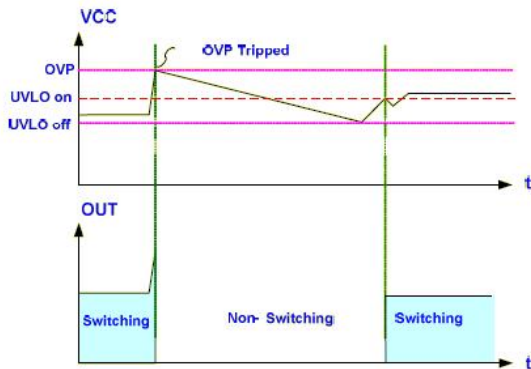

Fig. 2

Gate Clamp/Soft Driving

Driver is clamped to 17V by an internal clamping circuit. Those damages usually come from undesired over-voltage gate signals. Under the conditions listed below, the gate output will turn off immediately to protect the power circuit. The BW7386 also has soft driving function to minimize EMI.