

WIDE DRAM

2 MEG x 8 DRAM

5.0V, SELF REFRESH (MT4C2M8A1/2 S)
 3.0/3.3V, SELF REFRESH (MT4LC2M8A1/2 S)

FEATURES

- SELF REFRESH, or "Sleep Mode"
- Industry-standard x8 pinouts, timing, functions and packages
- Address entry: 12 row-address, 9 column-addresses (512ms)
- High-performance CMOS silicon-gate process
- Single +5V only or 3.0/3.3V only $\pm 10\%$ power supply
- All device pins are TTL-compatible
- Refresh modes: $\overline{\text{RAS}}$ -ONLY, $\overline{\text{CAS}}$ -BEFORE- $\overline{\text{RAS}}$ (CBR), HIDDEN and BATTERY BACKUP (BBU)
- Optional FAST-PAGE-MODE access cycle
- NONPERSISTENT MASKED WRITE access cycle (MT4(L)C2M8A2 S only)
- 4,096-cycle refresh (2,048-cycle refresh available as MT4(L)C2M8B1/2 S)
- Low power, 2mW standby; 400mW active, typical (5V)

OPTIONS

MARKING

- Timing

60ns access	-6
70ns access	-7
80ns access	-8
- Power Supply

5V $\pm 10\%$ only	4C
3.0/3.3V $\pm 10\%$ only	4LC
- MASKED WRITE

Not available	A1 S
Available	A2 S
- Packages

Plastic 28-pin SOJ (400 mil)	DJ
Plastic 28-pin TSOP (400 mil)	TG
Plastic 32-pin SOJ (400 mil)	DL
Plastic 32-pin TSOP (400 mil)	TL

PART DESCRIPTION

MT4C2M8A1 S	5V, NONMASKED WRITE
MT4C2M8A2 S	5V, MASKED WRITE
MT4LC2M8A1 S	3.0/3.3V, NONMASKED WRITE
MT4LC2M8A2 S	3.0/3.3V, MASKED WRITE

GENERAL DESCRIPTION

The MT4C2M8A1/2 S and MT4LC2M8A1/2 S are randomly accessed solid-state memories containing 16,777,216 bits organized in a x8 configuration. The

PIN ASSIGNMENT (Top View)

28-Pin SOJ (DC-4)

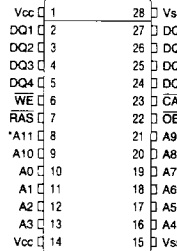

28-Pin TSOP (DD-3)

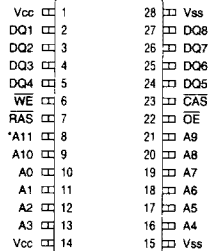

32-Pin SOJ (DC-5)

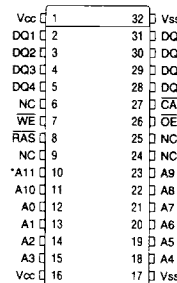

32-Pin TSOP (DD-4)

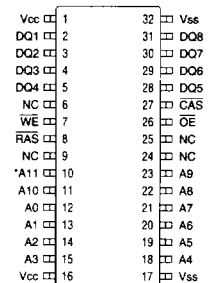

*NC on 11 row-address version

WIDE DRAM

MT4C2M8A1/2 S and the MT4LC2M8A1/2 S are the same DRAM versions except that the MT4LC2M8A1/2 S are low voltage versions of the MT4C2M8A1/2 S. The MT4LC2M8A1/2 S are designed to operate in either a 3.0V $\pm 10\%$ or a 3.3V $\pm 10\%$ memory system. All further references made for the MT4C2M8A1/2 S also apply to the MT4LC2M8A1/2 S, unless specifically stated otherwise. Each byte is uniquely addressed through the 21 address bits during READ or WRITE cycles. The address is entered first by RAS latching 12 bits (A0-11) and then CAS latching 9 bits (A0-A9).

The MT4C2M8A2 S has NONPERSISTENT MASKED WRITE, allowing it to perform WRITE-PER-BIT accesses.

FUNCTIONAL BLOCK DIAGRAM
 4096 ROWS

WIDE DRAM

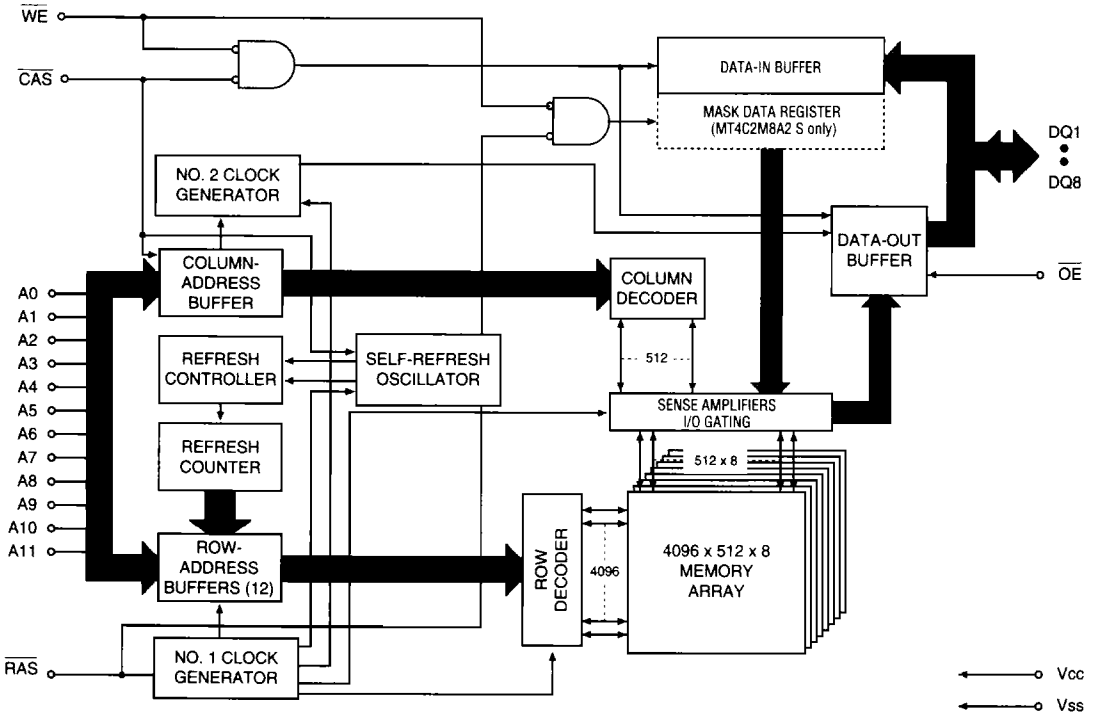

PIN DESCRIPTIONS

28-PIN DEVICE PIN NUMBERS	32-PIN DEVICE PIN NUMBERS	SYMBOL	TYPE	DESCRIPTION
7	8	\overline{RAS}	Input	Row-Address Strobe: \overline{RAS} is used to clock-in the 12 row-address bits and strobe the \overline{WE} and DQs in the MASKED WRITE mode (MT4C2M8A2 S only).
23	27	\overline{CAS}	Input	Column-Address Strobe: \overline{CAS} is used to clock-in the 9 column-address bits, enable the DRAM output buffers and strobe the data inputs on WRITE cycles.
6	7	\overline{WE}	Input	Write Enable: \overline{WE} is used to select a READ (\overline{WE} = HIGH) or WRITE (\overline{WE} = LOW) cycle. \overline{WE} also serves as a mask enable (\overline{WE} = LOW) at the falling edge of \overline{RAS} in a MASKED WRITE cycle (MT4C2M8A2 S).
22	26	\overline{OE}	Input	Output Enable: \overline{OE} enables the output buffers when taken LOW during a READ access cycle. \overline{RAS} and \overline{CAS} must be LOW and \overline{WE} must be HIGH before \overline{OE} will control the output buffers. Otherwise, the output buffers are in a High-Z state.
10-13, 16-21, 9, 8	12-15, 18-23, 11, 10	A0-A11	Input	Address Inputs: These inputs are multiplexed and clocked by \overline{RAS} and \overline{CAS} to select one byte out of the 2 Meg available words.
2-5, 24-27	2-5, 28-31	DQ1-DQ8	Input	Data I/O: Includes inputs, outputs or High-Z and/or output masked data input (for MASKED WRITE cycle only).
	6, 9, 24, 25	NC	-	No Connect: These pins should be either left unconnected or tied to ground.
1, 14	1, 16	Vcc	Supply	Power Supply: +5V \pm 10% (C), 2.7V to 3.6V (LC)
15, 28	17, 32	Vss	Supply	Ground

WIDE DRAM

FUNCTIONAL DESCRIPTION

Each bit is uniquely addressed through the 21 address bits during READ or WRITE cycles. First, \overline{RAS} is used to latch 12 bits (A0-A11) then, \overline{CAS} latches 9 bits (A0-A8).

The \overline{CAS} control also determines whether the cycle will be a refresh cycle (\overline{RAS} -ONLY) or an active cycle (READ, WRITE or READ-WRITE) once \overline{RAS} goes LOW.

READ or WRITE cycles are selected by \overline{WE} . A logic HIGH on \overline{WE} dictates READ mode while a logic LOW on \overline{WE} dictates WRITE mode. During a WRITE cycle, data-in (D) is latched by the falling edge of \overline{WE} or \overline{CAS} , whichever occurs last. Taking \overline{WE} LOW will initiate a WRITE cycle, selecting DQ1 through DQ8. If \overline{WE} goes LOW prior to \overline{CAS} going LOW, the output pin(s) remain open (High-Z) until the next \overline{CAS} cycle. If \overline{WE} goes LOW after \overline{CAS} goes LOW and data reaches the output pins, data-out (Q) is activated and retains the selected cell data as long as \overline{CAS} and \overline{OE} remain LOW (regardless of \overline{WE} or \overline{RAS}). This late \overline{WE} pulse results in a READ-WRITE cycle.

The eight data inputs and eight data outputs are routed through eight pins using common I/O and pin direction is controlled by \overline{OE} and \overline{WE} .

FAST-PAGE-MODE operations allow faster data operations (READ, WRITE or READ-MODIFY-WRITE) within a row-address-defined (A0-12) page boundary. The FAST-PAGE-MODE cycle is always initiated with a row-address strobed-in by \overline{RAS} followed by a column-address strobed-in by \overline{CAS} . \overline{CAS} may be toggled-in by holding \overline{RAS} LOW and strobing-in different column-addresses, thus executing faster memory cycles. Returning \overline{RAS} HIGH terminates the FAST-PAGE-MODE operation.

Returning \overline{RAS} and \overline{CAS} HIGH terminates a memory cycle and decreases chip current to a reduced standby level. The chip is also preconditioned for the next cycle during the \overline{RAS} HIGH time. Memory cell data is retained in its correct state by maintaining power and executing any \overline{RAS} cycle (READ, WRITE) or \overline{RAS} REFRESH cycle (\overline{RAS} -ONLY, CBR, or HIDDEN) so that all 4,096 combinations of \overline{RAS} addresses (A0-11) are executed at least every 512ms, regard-

less of sequence. The CBR REFRESH cycle will also invoke the refresh counter and controller for row-address control.

BBU is a CBR REFRESH performed at the extended refresh rate with CMOS input levels. This mode provides a very low-current, data-retention cycle. \overline{RAS} or \overline{CAS} time refers to the time at which \overline{RAS} or \overline{CAS} transition from HIGH to LOW).

SELF REFRESH is similar to BBU except that the DRAM provides its own internal clocking during sleep mode. Thus, an external clock is not required for additional power savings and design ease. The SELF REFRESH version retains the extended refresh rate of 512ms.

MASKED WRITE ACCESS CYCLE (MT4C2M8A2 S ONLY)

Every WRITE access cycle can be a MASKED WRITE, depending on the state of \overline{WE} at \overline{RAS} time. A MASKED WRITE is selected when \overline{WE} is LOW at \overline{RAS} time and mask data is supplied on the DQ pins.

The mask data present on the DQ1-DQ8 inputs at \overline{RAS} time will be written to an internal mask data register and will then act as an individual write enable for each of the corresponding DQ inputs. If a LOW (logic "0") is written to a mask data register bit, the input port for that bit is disabled during the subsequent WRITE operation and no new data will be written to that DRAM cell location. A HIGH (logic "1") on a mask data register bit enables the input port and allows normal WRITE operations to proceed. At \overline{CAS} time, the bits present on the DQ1-DQ8 inputs will be written to the DRAM (if the mask data bit was HIGH) or ignored (if the mask data bit was LOW).

In NONPERSISTENT MASKED WRITES, new mask data must be supplied each time a MASKED WRITE cycle is initiated.

Figure 1 illustrates the MT4C2M8A2 S MASKED WRITE operation (Note: \overline{RAS} or \overline{CAS} time refers to the time at which \overline{RAS} or \overline{CAS} transition from HIGH to LOW).

WIDE DRAM

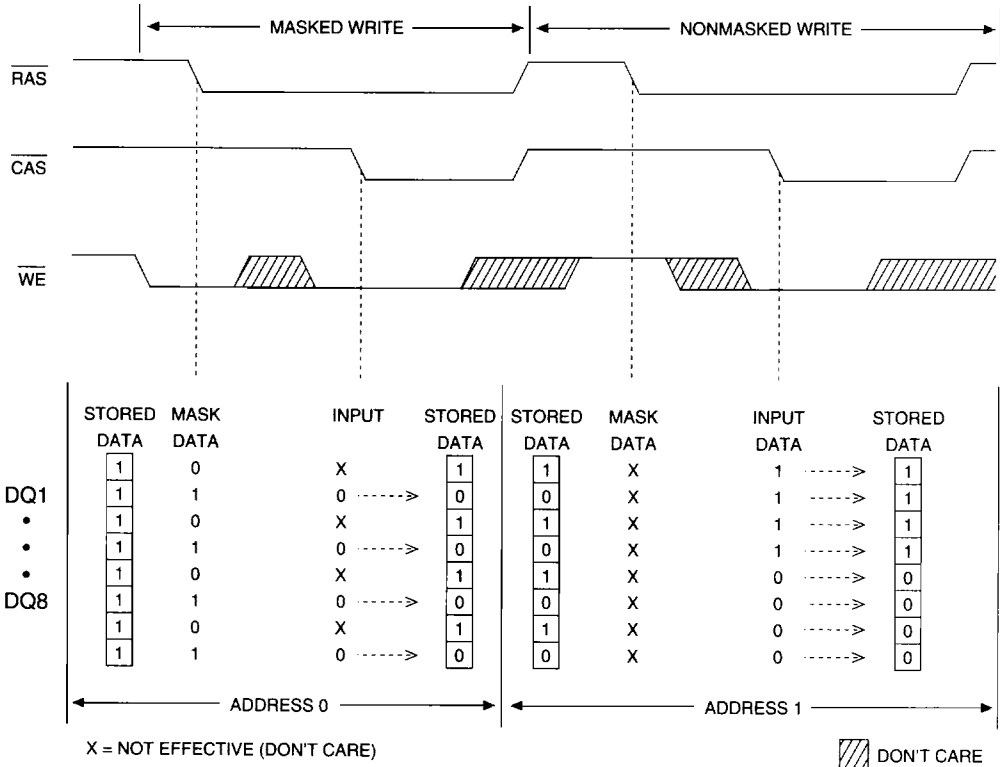

Figure 1
MT4C2M8A2 S MASKED WRITE EXAMPLE

TRUTH TABLE

FUNCTION	RAS	CAS	WE	OE	ADDRESSES		DQs	NOTES	
					t _R	t _C			
Standby	H	H→X	X	X	X	X	High-Z		
READ	L	L	H	L	ROW	COL	Data-Out		
EARLY-WRITE	L	L	L	X	ROW	COL	Data-In	1	
READ-WRITE	L	L	H→L	L→H	ROW	COL	Data-Out, Data-In	1	
FAST-PAGE-MODE READ	1st Cycle	L	H→L	H	L	ROW	COL	Data-Out	
	2nd Cycle	L	H→L	H	L	n/a	COL	Data-Out	
FAST-PAGE-MODE WRITE	1st Cycle	L	H→L	L	X	ROW	COL	Data-In	1
	2nd Cycle	L	H→L	L	X	n/a	COL	Data-In	1
FAST-PAGE-MODE READ-WRITE	1st Cycle	L	H→L	H→L	L→H	ROW	COL	Data-Out, Data-In	1
	2nd Cycle	L	H→L	H→L	L→H	n/a	COL	Data-Out, Data-In	1
HIDDEN REFRESH	READ	L→H→L	L	H	L	ROW	COL	Data-Out	
	WRITE	L→H→L	L	L	X	ROW	COL	Data-In	1, 2
RAS-ONLY REFRESH	L	H	X	X	ROW	n/a	High-Z		
CBR REFRESH	H→L	L	H	X	X	X	High-Z		
BBU REFRESH	H→L	L	H	X	X	X	High-Z		
SELF REFRESH	H→L	L	H	X	X	X	High-Z		

NOTE: 1. Data-in will be dependent on the mask provided (MT4C2M8A2 S only). Refer to Figure 1.
 2. EARLY WRITE only.

WIDE DRAM

ABSOLUTE MAXIMUM RATINGS*

Voltage on Vcc supply relative to Vss (5V)	-1V to +7V
Voltage on Vcc supply relative to Vss (3V)	-1V to +4.6V
Operating Temperature, T _A (ambient)	0°C to +70°C
Storage Temperature (plastic)	-55°C to +150°C
Power Dissipation	1W
Short Circuit Output Current	50mA

*Stresses greater than those listed under "Absolute Maximum Ratings" may cause permanent damage to the device. This is a stress rating only and functional operation of the device at these or any other conditions above those indicated in the operational sections of this specification is not implied. Exposure to absolute maximum rating conditions for extended periods may affect reliability.

DC OPERATING SPECIFICATIONS FOR 5V VERSION

(Notes: 1, 3, 4, 6, 7, 30) (0°C ≤ T_A ≤ 70°C; V_{CC} = 5V ±10%)

PARAMETER/CONDITION	SYMBOL	MIN	MAX	UNITS	NOTES
Supply Voltage	V _{CC}	4.5	5.5	V	1, 30
Input High (Logic 1) Voltage, all inputs	V _{IH}	2.4	V _{CC} +1	V	1
Input Low (Logic 0) Voltage, all inputs	V _{IL}	-1.0	0.8	V	1
INPUT LEAKAGE CURRENT Any input 0V ≤ V _{IN} ≤ V _{CC} (All other pins not under test = 0V)	I _I	-2	2	μA	
OUTPUT LEAKAGE CURRENT (Q is disabled; 0V ≤ V _{OUT} ≤ 5.5V)	I _{OZ}	-10	10	μA	
OUTPUT LEVELS Output High Voltage (I _{OUT} = -2.5mA)	V _{OH}	2.4		V	
Output Low Voltage (I _{OUT} = 2.1mA)	V _{OL}		0.4	V	

DC OPERATING SPECIFICATIONS FOR 3.0/3.3V VERSION

(Notes: 1, 3, 4, 6, 7, 31) (0°C ≤ T_A ≤ 70°C; V_{CC} = 2.7V to 3.6V)

PARAMETER/CONDITION	SYMBOL	MIN	MAX	UNITS	NOTES
Supply Voltage	V _{CC}	2.7	3.6	V	1, 31
Input High (Logic 1) Voltage, all inputs	V _{IH}	2.0	V _{CC} +1	V	1
Input Low (Logic 0) Voltage, all inputs	V _{IL}	-1.0	0.8	V	1
INPUT LEAKAGE CURRENT Any input 0V ≤ V _{IN} ≤ V _{CC} (All other pins not under test = 0V)	I _I	-2	2	μA	
OUTPUT LEAKAGE CURRENT (Q is disabled; 0V ≤ V _{OUT} ≤ 3.6V)	I _{OZ}	-10	10	μA	
OUTPUT LEVELS Output High Voltage (I _{OUT} = -2mA)	V _{OH}	2.4		V	
Output Low Voltage (I _{OUT} = 2mA)	V _{OL}		0.4	V	

DC OPERATING SPECIFICATIONS FOR 5V VERSION

 (Notes: 1, 3, 4, 6, 7, 30) (0°C ≤ T_A ≤ 70°C; V_{CC} = 5V ±10%)

PARAMETER/CONDITION	SYMBOL	MAX			UNITS	NOTES
		-6	-7	-8		
STANDBY CURRENT: TTL ($\overline{RAS} = \overline{CAS} = V_{IH}$)	I _{CC1}	2	2	2	mA	
STANDBY CURRENT: CMOS ($\overline{RAS} = \overline{CAS} = V_{CC} - 0.2V$)	I _{CC2}	200	200	200	μA	25
OPERATING CURRENT: Random READ/WRITE Average power supply current (\overline{RAS} , \overline{CAS} , Address Cycling: $t'RC = t'RC$ [MIN])	I _{CC3}	110	100	90	mA	3, 4, 32
OPERATING CURRENT: FAST-PAGE-MODE Average power supply current ($\overline{RAS} = V_{IL}$, \overline{CAS} , Address Cycling: $t'PC = t'PC$ [MIN]; $t'CP$, $t'ASC = 10ns$)	I _{CC4}	80	70	60	mA	3, 4, 32
REFRESH CURRENT: \overline{RAS} -ONLY Average power supply current (\overline{RAS} Cycling, $\overline{CAS} = V_{IH}$: $t'RC = t'RC$ [MIN])	I _{CC5}	110	100	90	mA	3, 32
REFRESH CURRENT: CBR Average power supply current (\overline{RAS} , \overline{CAS} , Address Cycling: $t'RC = t'RC$ [MIN])	I _{CC6}	110	100	90	mA	3, 5
REFRESH CURRENT: BBU Average power supply current during BBU REFRESH: $\overline{CAS} = 0.2V$ or CBR cycling; $\overline{RAS} = t'RAS$ (MIN) to 300ns; \overline{WE} , A0-A11 and $D_{IN} = V_{CC} - 0.2V$ (D_{IN} may be left open), $t'RC = 125\mu s$ (1,024 rows at $125\mu s = 128ms$)	I _{CC7}	300	300	300	μA	3, 30
REFRESH CURRENT: SELF Average power supply current during SELF REFRESH: CBR cycle with $\overline{RAS} \geq t'RASS$ (MIN) and \overline{CAS} held LOW; $\overline{WE} = V_{CC} - 0.2V$; A0-A9 and $D_{IN} = V_{CC} - 0.2V$ or $0.2V$ (D_{IN} may be left open)	I _{CC8}	300	300	300	μA	5

WIDE DRAM

DC OPERATING SPECIFICATIONS FOR 3.0/3.3V VERSION

(Notes: 1, 3, 4, 6, 7, 31) ($0^{\circ}\text{C} \leq T_A \leq 70^{\circ}\text{C}$; $V_{CC} = 2.7\text{V}$ to 3.6V)

PARAMETER/CONDITION	SYMBOL	MAX			UNITS	NOTES
		-6	-7	-8		
STANDBY CURRENT: TTL ($\overline{\text{RAS}} = \overline{\text{CAS}} = V_{IH}$)	I _{CC1}	2	2	2	mA	
STANDBY CURRENT: CMOS ($\overline{\text{RAS}} = \overline{\text{CAS}} = V_{CC} - 0.2\text{V}$)	I _{CC2}	200	200	200	μA	25
OPERATING CURRENT: Random READ/WRITE Average power supply current ($\overline{\text{RAS}}$, $\overline{\text{CAS}}$, Address Cycling: $t^{\text{RC}} = t^{\text{RC}} [\text{MIN}]$)	I _{CC3}	110	100	90	mA	3, 4, 32
OPERATING CURRENT: FAST-PAGE-MODE Average power supply current ($\overline{\text{RAS}} = V_{IL}$, $\overline{\text{CAS}}$, Address Cycling: $t^{\text{PC}} = t^{\text{PC}} [\text{MIN}]$; t^{CP} , $t^{\text{ASC}} = 10\text{ns}$)	I _{CC4}	80	70	60	mA	3, 4, 32
REFRESH CURRENT: $\overline{\text{RAS}}$ -ONLY Average power supply current ($\overline{\text{RAS}}$ Cycling, $\overline{\text{CAS}} = V_{IH}$; $t^{\text{RC}} = t^{\text{RC}} [\text{MIN}]$)	I _{CC5}	110	100	90	mA	3, 32
REFRESH CURRENT: CBR Average power supply current ($\overline{\text{RAS}}$, $\overline{\text{CAS}}$, Address Cycling: $t^{\text{RC}} = t^{\text{RC}} [\text{MIN}]$)	I _{CC6}	110	100	90	mA	3, 5
REFRESH CURRENT: BBU Average power supply current during BBU REFRESH: $\overline{\text{CAS}} = 0.2\text{V}$ or CBR cycling; $\overline{\text{RAS}} = t^{\text{RAS}} (\text{MIN})$ to 300ns; $\overline{\text{WE}}$, A0-A11 and $\text{DIN} = V_{CC} - 0.2\text{V}$ (DIN may be left open), $t^{\text{RC}} = 125\mu\text{s}$ (1,024 rows at $125\mu\text{s} = 128\text{ms}$)	I _{CC7}	300	300	300	μA	3, 30
REFRESH CURRENT: SELF Average power supply current during SELF REFRESH: CBR cycle with $\overline{\text{RAS}} \geq t^{\text{RAS}} (\text{MIN})$ and $\overline{\text{CAS}}$ held LOW; $\overline{\text{WE}} = V_{CC} - 0.2\text{V}$; A0-A9 and $\text{DIN} = V_{CC} - 0.2\text{V}$ or 0.2V (DIN may be left open)	I _{CC8}	300	300	300	μA	5

WIDE DRAM

MICRON**MT4(L)C2M8A1/2 S
2 MEG x 8 WIDE DRAM****CAPACITANCE**

PARAMETER	SYMBOL	MAX	UNITS	NOTES
Input Capacitance: A0-A11	C _{i1}	5	pF	2
Input Capacitance: $\overline{\text{RAS}}$, $\overline{\text{CAS}}$, $\overline{\text{WE}}$, $\overline{\text{OE}}$	C _{i2}	7	pF	2
Input/Output Capacitance: DQ	C _{i0}	7	pF	2

ELECTRICAL CHARACTERISTICS AND RECOMMENDED AC OPERATING CONDITIONS(Notes: 6, 7, 8, 9, 10, 11, 12, 13) ($0^{\circ}\text{C} \leq T_A \leq +70^{\circ}\text{C}$)

AC CHARACTERISTICS	SYM	-6		-7		-8		UNITS	NOTES
		MIN	MAX	MIN	MAX	MIN	MAX		
Random READ or WRITE cycle time	¹ RC	110		130		150		ns	
READ-WRITE cycle time	¹ RWC	155		180		200		ns	
FAST-PAGE-MODE READ or WRITE cycle time	¹ PC	35		40		45		ns	
FAST-PAGE-MODE READ-WRITE cycle time	¹ PRWC	85		95		100		ns	
Access time from $\overline{\text{RAS}}$	¹ RAC		60		70		80	ns	14
Access time from $\overline{\text{CAS}}$	¹ CAC		15		20		20	ns	15
Output Enable	¹ OE		15		15		15	ns	
Access time from column-address	¹ AA		30		35		40	ns	
Access time from $\overline{\text{CAS}}$ precharge	¹ CPA		35		40		45	ns	
$\overline{\text{RAS}}$ pulse width	¹ RAS	60	100,000	70	100,000	80	100,000	ns	
$\overline{\text{RAS}}$ pulse width (FAST-PAGE-MODE)	¹ RASP	60	100,000	70	100,000	80	100,000	ns	
$\overline{\text{RAS}}$ hold time	¹ RSH	15		20		20		ns	
$\overline{\text{RAS}}$ precharge time	¹ RP	40		50		60		ns	
$\overline{\text{CAS}}$ pulse width	¹ CAS	15	100,000	20	100,000	20	100,000	ns	
$\overline{\text{CAS}}$ hold time	¹ CSH	60		70		80		ns	
$\overline{\text{CAS}}$ precharge time	¹ CPN	10		10		10		ns	16
$\overline{\text{CAS}}$ precharge time (FAST-PAGE-MODE)	¹ CP	10		10		10		ns	
$\overline{\text{RAS}}$ to $\overline{\text{CAS}}$ delay time	¹ RCD	15	45	20	50	20	60	ns	17
$\overline{\text{CAS}}$ to $\overline{\text{RAS}}$ precharge time	¹ CRP	5		5		5		ns	
Row-address setup time	¹ ASR	0		0		0		ns	
Row-address hold time	¹ RAH	10		10		10		ns	
$\overline{\text{RAS}}$ to column-address delay time	¹ RAD	15	30	15	35	15	40	ns	18
Column-address setup time	¹ ASC	0		0		0		ns	
Column-address hold time	¹ CAH	10		15		15		ns	
Column-address hold time (referenced to $\overline{\text{RAS}}$)	¹ AR	50		55		60		ns	
Column-address to $\overline{\text{RAS}}$ lead time	¹ RAL	30		35		40		ns	
Read command setup time	¹ RCS	0		0		0		ns	26
Read command hold time (referenced to $\overline{\text{CAS}}$)	¹ RCH	0		0		0		ns	19, 26
Read command hold time (referenced to $\overline{\text{RAS}}$)	¹ RRH	0		0		0		ns	19
$\overline{\text{CAS}}$ to output in Low-Z	¹ CLZ	3		3		3		ns	34
Output buffer turn-off delay	¹ OFF	3	15	3	20	3	20	ns	20, 29, 34

ELECTRICAL CHARACTERISTICS AND RECOMMENDED AC OPERATING CONDITIONS

 (Notes: 6, 7, 8, 9, 10, 11, 12, 13) ($0^{\circ}\text{C} \leq T_A \leq +70^{\circ}\text{C}$)

AC CHARACTERISTICS	PARAMETER	SYM	-6		-7		-8		UNITS	NOTES
			MIN	MAX	MIN	MAX	MIN	MAX		
WE command setup time	t^1_{WCS}		0		0		0		ns	21, 26
Write command hold time	t^1_{WCH}		10		15		15		ns	26
Write command hold time (referenced to RAS)	t^1_{WCR}		45		55		60		ns	26
Write command pulse width	t^1_{WP}		10		15		15		ns	26
Write command to RAS lead time	t^1_{RWL}		15		20		20		ns	26
Write command to CAS lead time	t^1_{CWL}		15		20		20		ns	26
Data-in setup time	t^1_{DS}		0		0		0		ns	22
Data-in hold time	t^1_{DH}		10		15		15		ns	22
Data-in hold time (referenced to RAS)	t^1_{DHR}		45		55		60		ns	
RAS to WE delay time	t^1_{RWD}		85		95		105		ns	21
Column-address to WE delay time	t^1_{AWD}		55		60		65		ns	21
CAS to WE delay time	t^1_{CWD}		40		45		45		ns	21
Transition time (rise or fall)	t^1_{T}		3	50	3	50	3	50	ns	9, 10
Refresh period (4,096 cycles)	t^1_{REF}			512		512		512	ms	
RAS to CAS precharge time	t^1_{RPC}		0		0		0		ns	
CAS setup time (CBR REFRESH)	t^1_{CSR}		5		5		5		ns	5
CAS hold time (CBR REFRESH)	t^1_{CHR}		15		15		15		ns	5
WE hold time (MASKED WRITE and CBR REFRESH)	t^1_{WRH}		15		15		15		ns	26
WE setup time (CBR REFRESH)	t^1_{WRP}		10		10		10		ns	26
WE setup time (MASKED WRITE)	t^1_{WRS}		10		10		10		ns	26
OE setup prior to RAS during HIDDEN REFRESH cycle	t^1_{ORD}		0		0		0		ns	
Output disable	t^1_{OD}		3	15	3	15	3	15	ns	29, 34
OE hold time from WE during READ-MODIFY-WRITE cycle	t^1_{OEH}		15		15		15		ns	28
RAS pulse width during SELF REFRESH cycle	t^1_{RASS}		100		100		100		μs	
RAS precharge time during SELF REFRESH cycle	t^1_{RPS}		150		150		150		ns	
CAS hold time during SELF REFRESH cycle	t^1_{CHS}		-70		-70		-70		ns	

WIDE DRAM

NOTES

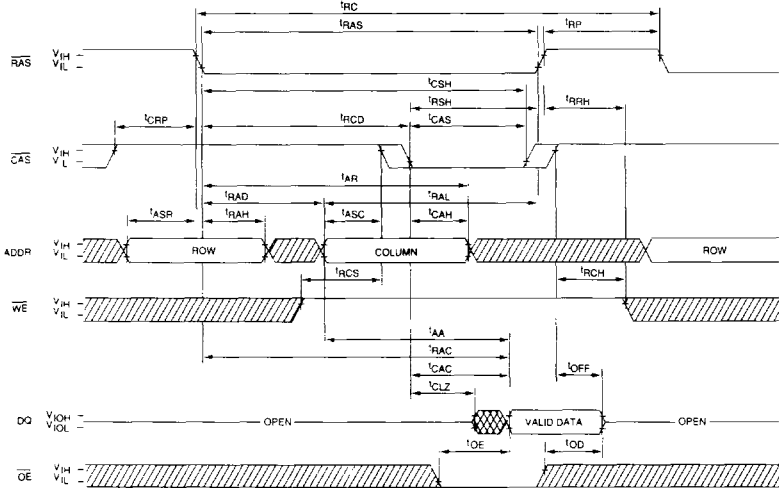

1. All voltages referenced to V_{SS} .
2. This parameter is sampled. $V_{CC} = 5V \pm 10\%$; $f = 1 \text{ MHz}$.
3. I_{CC} is dependent on cycle rates.
4. I_{CC} is dependent on output loading and cycle rates. Specified values are obtained with minimum cycle time and the outputs open.
5. Enables on-chip refresh and address counters.
6. The minimum specifications are used only to indicate cycle time at which proper operation over the full temperature range ($0^\circ\text{C} \leq T_A \leq 70^\circ\text{C}$) is assured.
7. An initial pause of $100\mu\text{s}$ is required after power-up followed by eight $\overline{\text{RAS}}$ refresh cycles ($\overline{\text{RAS}}$ -ONLY or CBR) before proper device operation is assured. The eight $\overline{\text{RAS}}$ cycle wake-ups should be repeated any time the $\overline{\text{REF}}$ refresh requirement is exceeded.
8. AC characteristics assume $t_T = 5\text{ns}$.
9. V_{IH} (MIN) and V_{IL} (MAX) are reference levels for measuring timing of input signals. Transition times are measured between V_{IH} and V_{IL} (or between V_{IL} and V_{IH}).
10. In addition to meeting the transition rate specification, all input signals must transit between V_{IH} and V_{IL} (or between V_{IL} and V_{IH}) in a monotonic manner.
11. If $\overline{\text{CAS}} = V_{IH}$, data output is high impedance.
12. If $\overline{\text{CAS}} = V_{IL}$, data output may contain data from the last valid READ cycle.
13. Measured with a load equivalent to one TTL gate and 50pF .
14. Assumes that $t_{RCD} < t_{RCD}(\text{MAX})$. If t_{RCD} is greater than the maximum recommended value shown in this table, t_{RAC} will increase by the amount that t_{RCD} exceeds the value shown.
15. Assumes that $t_{RCD} \geq t_{RCD}(\text{MAX})$.
16. If $\overline{\text{CAS}}$ is LOW at the falling edge of $\overline{\text{RAS}}$, Q will be maintained from the previous cycle. To initiate a new cycle and clear the Q buffer, $\overline{\text{CAS}}$ must be pulsed HIGH for CPN .
17. Operation within the $t_{RCD}(\text{MAX})$ limit ensures that $t_{RAC}(\text{MAX})$ can be met. $t_{RCD}(\text{MAX})$ is specified as a reference point only; if t_{RCD} is greater than the specified $t_{RCD}(\text{MAX})$ limit, access time is controlled exclusively by t_{CAC} .
18. Operation within the t_{RAD} limit ensures that $t_{RCD}(\text{MAX})$ can be met. $t_{RAD}(\text{MAX})$ is specified as a reference point only; if t_{RAD} is greater than the specified $t_{RAD}(\text{MAX})$ limit, access time is controlled exclusively by t_{AA} .
19. Either t_{RCH} or t_{RRH} must be satisfied for a READ cycle.
20. $t_{OFF}(\text{MAX})$ defines the time at which the output achieves the open circuit condition; it is not a reference to V_{OH} or V_{OL} .
21. t_{WCS} , t_{RWD} , t_{AWD} and t_{CWD} are restrictive operating parameters in LATE-WRITE and READ-MODIFY-WRITE cycles only. If $t_{WCS} \geq t_{WCS}(\text{MIN})$, the cycle is an EARLY-WRITE cycle and the data output will remain an open circuit throughout the entire cycle. If $t_{RWD} \geq t_{RWD}(\text{MIN})$, $t_{AWD} \geq t_{AWD}(\text{MIN})$ and $t_{CWD} \geq t_{CWD}(\text{MIN})$, the cycle is a READ-WRITE and the data output will contain data read from the selected cell. If neither of the above conditions is met, the state of data-out is indeterminate. $\overline{\text{OE}}$ held HIGH and $\overline{\text{WE}}$ taken LOW after $\overline{\text{CAS}}$ goes LOW results in a LATE-WRITE ($\overline{\text{OE}}$ -controlled) cycle.
22. These parameters are referenced to $\overline{\text{CAS}}$ leading edge in EARLY-WRITE cycles and $\overline{\text{WE}}$ leading edge in LATE-WRITE or READ-MODIFY-WRITE cycles.
23. During a READ cycle, if $\overline{\text{OE}}$ is LOW then taken HIGH before $\overline{\text{CAS}}$ goes HIGH, Q goes open. If $\overline{\text{OE}}$ is tied permanently LOW, LATE-WRITE or READ-MODIFY-WRITE operations are not possible.
24. A HIDDEN REFRESH may also be performed after a WRITE cycle. In this case, $\overline{\text{WE}} = \text{LOW}$ and $\overline{\text{OE}} = \text{HIGH}$.
25. All other inputs at $V_{CC} - 0.2V$.
26. Write command is defined as $\overline{\text{WE}}$ going LOW.
27. MT4C2M8A2 S only.
28. LATE-WRITE and READ-MODIFY-WRITE cycles must have both t_{OD} and t_{OE} met ($\overline{\text{OE}}$ HIGH during WRITE cycle) in order to ensure that the output buffers will be open during the WRITE cycle. If $\overline{\text{OE}}$ is taken back LOW while $\overline{\text{CAS}}$ remains LOW, the DQs will remain open.
29. The DQs open during READ cycles once t_{OD} or t_{OFF} occur. If $\overline{\text{CAS}}$ goes HIGH before $\overline{\text{OE}}$, the DQs will open regardless of the state of $\overline{\text{OE}}$. If $\overline{\text{CAS}}$ stays LOW while $\overline{\text{OE}}$ is brought HIGH, the DQs will open. If $\overline{\text{OE}}$ is brought back LOW ($\overline{\text{CAS}}$ still LOW), the DQs will provide the previously read data.
30. BBU current is reduced as t_{RAS} is reduced from its maximum specification during BBU cycle.
31. The 3.0/3.3V version is restricted to operate between 2.7 V and 3.6V only. The -6 speed version is only valid for $V_{CC} = 3.0V$ to 3.6 V whereas the -7 and -8 speed versions are valid for $V_{CC} = 2.7V$ to 3.6V.
32. The 3.0/3.3V version is restricted to operate between 2.7 V and 3.6V only.
33. Column-address changed once while $\overline{\text{RAS}} = V_{IL}$ and $\overline{\text{CAS}} = V_{IH}$.
34. The 3ns minimum is a parameter guaranteed by design.

READ CYCLE

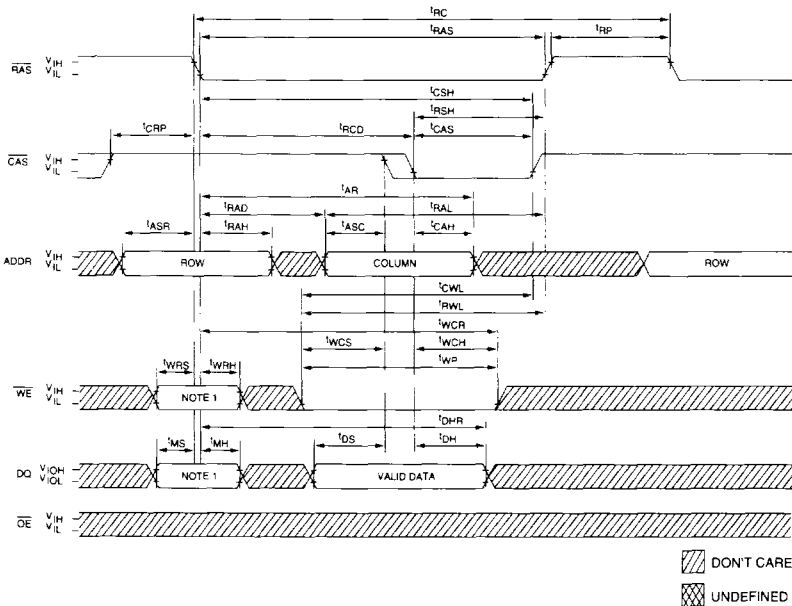

EARLY-WRITE CYCLE



 DON'T CARE
 UNDEFINED

NOTE: 1. Applies to MT4C2M8A2 S only; \overline{WE} and DQ inputs on MT4C2M8A1 S are "don't care" at \overline{RAS} time. \overline{WE} selects between normal WRITE and MASKED WRITE at \overline{RAS} time. The DQ inputs are "don't care" for a normal WRITE (\overline{WE} HIGH at \overline{RAS} time). The DQ inputs provide the mask data at \overline{RAS} time for a MASKED WRITE, \overline{WE} LOW at \overline{RAS} time.

READ-WRITE CYCLE
(LATE-WRITE and READ-MODIFY-WRITE CYCLES)

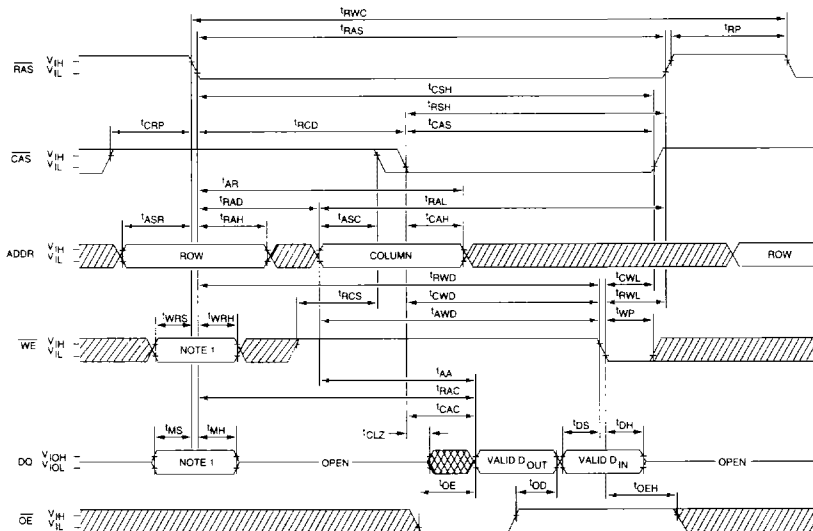

FAST-PAGE-MODE READ CYCLE

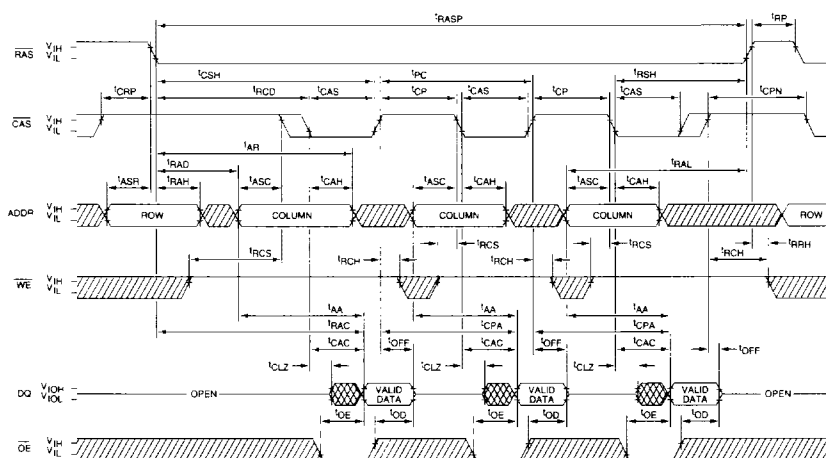

▨ DON'T CARE
▩ UNDEFINED

NOTE: 1. Applies to MT4C2M8A2 S only; \overline{WE} and DQ inputs on MT4C2M8A1 S are "don't care" at RAS time. \overline{WE} selects between normal WRITE and MASKED WRITE at RAS time. The DQ inputs are "don't care" for a normal WRITE (\overline{WE} HIGH at RAS time). The DQ inputs provide the mask data at \overline{RAS} time for a MASKED WRITE, \overline{WE} LOW at RAS time.

WIDE DRAM

FAST-PAGE-MODE READ-EARLY-WRITE CYCLE
(Pseudo READ-MODIFY-WRITE)

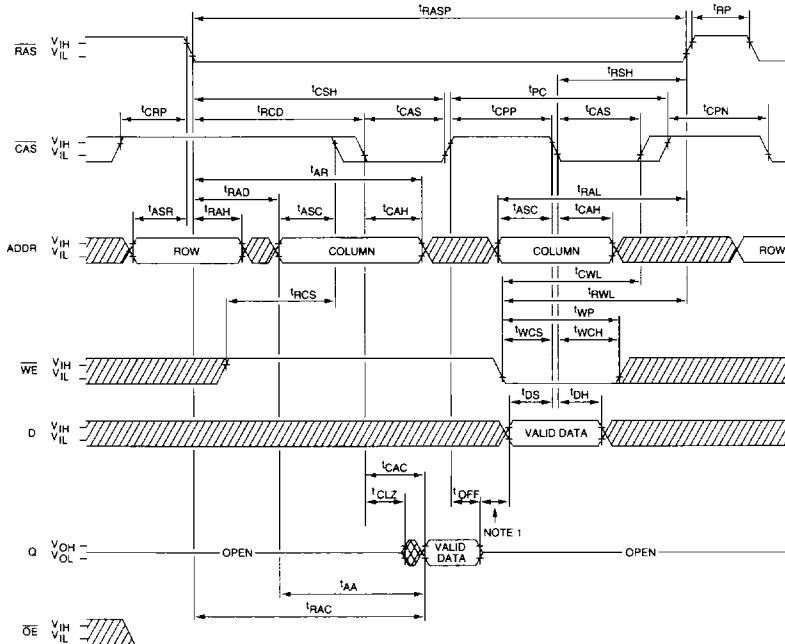

WIDE DRAM

NOTE: 1. Do not drive data prior to High-Z; that is completion of tOFF. tCPP is equal to tOFF + tDS(MIN) + guardband between data-out and driving new data-in.

CBR REFRESH CYCLE
(A0-A11; OE = DON'T CARE)

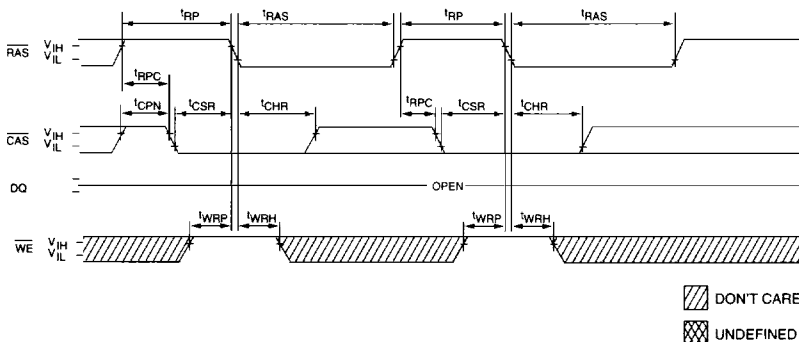

BBU REFRESH CYCLE
(A0-A11; \overline{OE} = DON'T CARE)

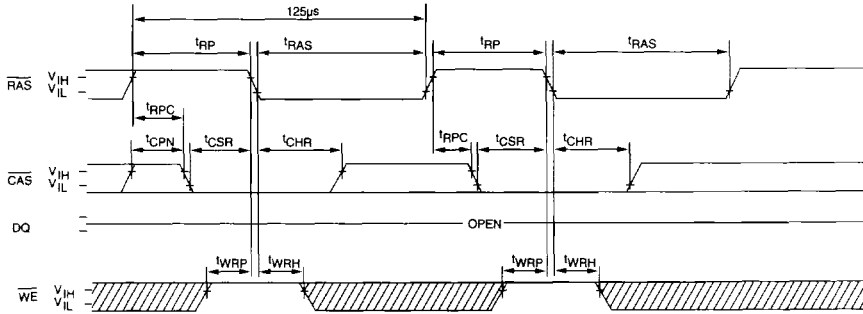

SELF REFRESH CYCLE ("SLEEP MODE")
(A0-A11; \overline{OE} = DON'T CARE)

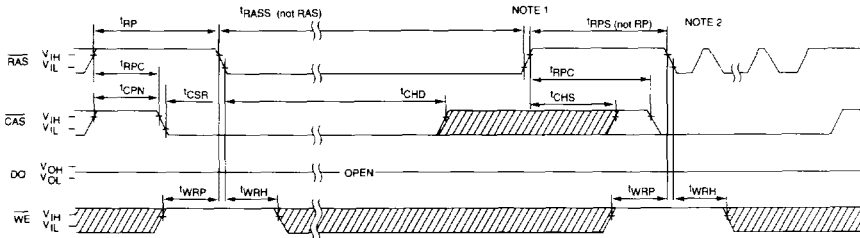

RAS-ONLY REFRESH CYCLE
(\overline{OE} and \overline{WE} = DON'T CARE)

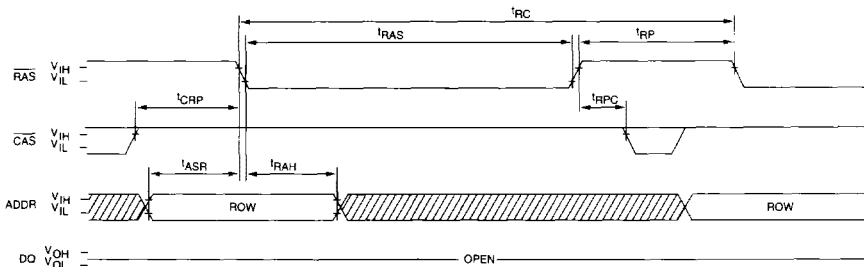

DON'T CARE
 UNDEFINED

WIDE DRAM

HIDDEN REFRESH CYCLE²⁴
($\overline{WE} = \text{HIGH}; \overline{OE} = \text{LOW}$)

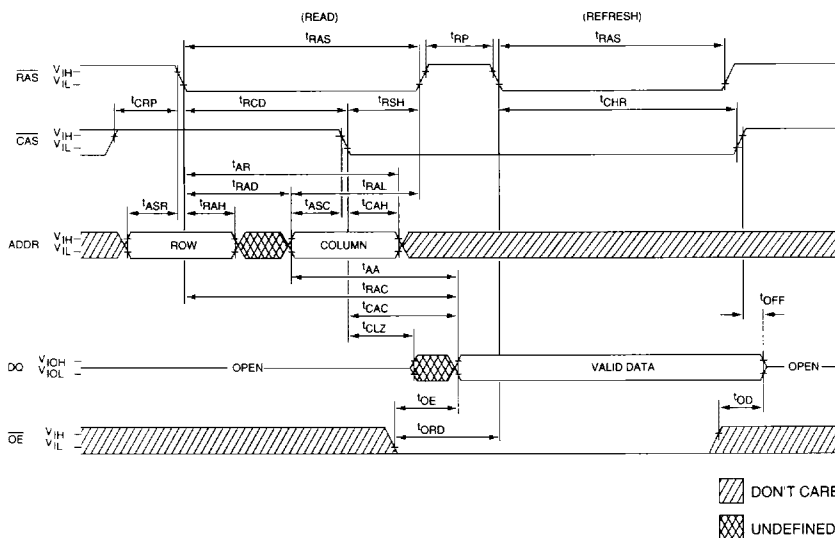

WIDE DRAM