

ISOMETRIC

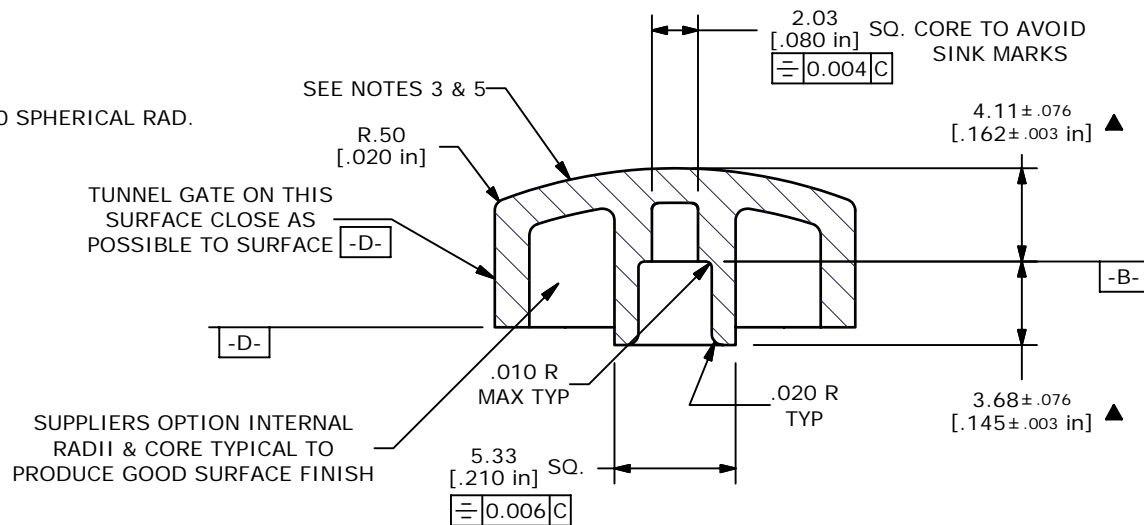
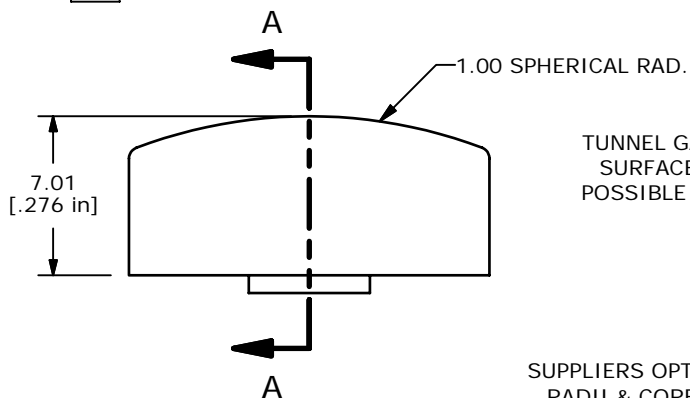

SECTION A-A

NOTES:

1. ALL DIMENSIONS IN INCHES
2. MATERIAL: ABS
3. SURFACE FINISH: FINE EDM MACHINE FINISH
4. COLOR: BLUE, PANTONE 3005U
5. EXTERNAL SURFACES TO BE FREE OF SINK MARKS & BLEMISHES
6. ▲ DESIGNATE MAJOR FEATURE:
7. UNLESS OTHERWISE SPECIFIED TOLERANCE TO BE  $\pm .005$
8. 2002/95/EC (ROHS) COMPLIANT

E	16863	FIXED NOTE TO 3005U	1/12/2007	TN
D	16858	PANTONE NOTE TO 30054	1/12/07	TN
C	16503	CONVERTED, COLOR CHANGED	10/04/2006	TN
REV	PCR NO	DESCRIPTION	DATE	BY



TITLE 320.09 CAP BLUE

THE INFORMATION CONTAINED IN THIS DOCUMENT IS PROPRIETARY TO E-SWITCH AND IS NOT TO BE COPIED OR TRANSFERRED

SCALE	DATE	DR	DWG	REV
3:1	1/12/2007	TN	B099463	E