

Single-channel high-side driver with analog current sense for 24 V automotive applications

Datasheet – production data

Features

Max transient supply voltage	V_{CC}	58 V
Operating voltage range	V_{CC}	8 V to 36 V
Typ on-state resistance	R_{ON}	6 m Ω
Current limitation (typ)	I_{LIM}	115 A
Off-state supply current	I_S	2 μ A ⁽¹⁾

1. Typical value with all loads connected.

- General
 - Very low standby current
 - 3 V CMOS compatible input
 - Optimized electromagnetic emission
 - Very low electromagnetic susceptibility
 - Compliance with 2002/95/EC European directive
 - Fault reset standby pin (FR_Stby)
- Diagnostic functions
 - Proportional load current sense
 - Current sense precision for wide range currents
 - Off-state open-load detection
 - Output short to V_{CC} detection
 - Overload and short to ground latch-off
 - Thermal shutdown latch-off
 - Very low current sense leakage
- Protections
 - Undervoltage shutdown
 - Overvoltage clamp
 - Load current limitation
 - Self limiting of fast thermal transients
 - Protection against loss of ground and loss of V_{CC}
 - Thermal shutdown
 - Reverse battery protected with self switch of the PowerMOS
 - Electrostatic discharge protection

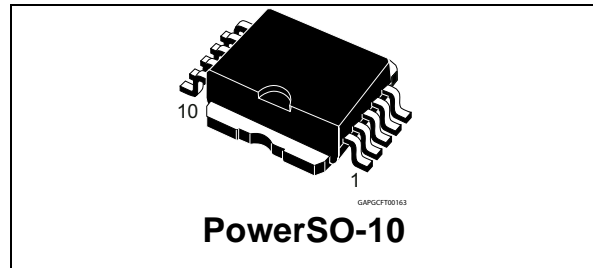

Application

- All types of resistive, inductive and capacitive loads

Description

The VN5T006ASP-E is a device made using STMicroelectronics® VIPower® VN5T006ASP-E technology, intended for driving resistive or inductive loads with one side connected to ground. Active V_{CC} pin voltage clamp protects the device against low energy spikes.

This device integrates an analog current sense which delivers a current proportional to the load current. Fault conditions such as overload, overtemperature or short to V_{CC} are reported via the current sense pin.

Output current limitation protects the device in overload condition. The device latches off in case of overload or thermal shutdown.

The device is reset by a low-level pass on the fault reset standby pin.

A permanent low level on the inputs and fault reset standby pin disables all outputs and sets the device in standby mode.

Contents

1	Block diagram and pin description	5
2	Electrical specifications	7
2.1	Absolute maximum ratings	7
2.2	Thermal data	8
2.3	Electrical characteristics	9
2.4	Electrical characteristics curves	19
3	Application information	21
3.1	Load dump protection	21
3.2	MCU I/Os protection	21
3.3	Maximum demagnetization energy (VCC = 24 V)	22
4	Package and PCB thermal data	23
4.1	PowerSO-10 thermal data	23
5	Package information	26
5.1	ECOPACK [®]	26
5.2	PowerSO-10 mechanical data	26
5.3	Packing information	28
6	Order codes	29
7	Revision history	30

List of tables

Table 1.	Pin function	5
Table 2.	Suggested connections for unused and not connected pins	6
Table 3.	Absolute maximum ratings	7
Table 4.	Thermal data	8
Table 5.	Power section	9
Table 6.	Switching ($V_{CC} = 24\text{ V}$; $T_j = 25^\circ\text{C}$)	9
Table 7.	Logic inputs	10
Table 8.	Protections and diagnostics	11
Table 9.	Current sense ($8\text{ V} < V_{CC} < 36\text{ V}$)	12
Table 10.	Open-load detection ($FR_Stby = 5\text{ V}$)	13
Table 11.	Truth table	17
Table 12.	Electrical transient requirements (part 1)	18
Table 13.	Electrical transient requirements (part 2)	18
Table 14.	Electrical transient requirements (part 3)	18
Table 15.	Thermal parameters	25
Table 16.	PowerSO-10 mechanical data	27
Table 17.	Device summary	29
Table 18.	Document revision history	30

List of figures

Figure 1.	Block diagram	5
Figure 2.	Configuration diagram (top view)	6
Figure 3.	Current and voltage conventions	7
Figure 4.	T_{reset} definition	10
Figure 5.	T_{stby} definition	11
Figure 6.	Output stuck to V_{CC} detection delay time at FR_{STBY} activation	14
Figure 7.	Current sense delay characteristics	14
Figure 8.	Open-load off-state delay timing	15
Figure 9.	Switching characteristics	15
Figure 10.	Delay response time between rising edge of output current and rising edge of current sense	16
Figure 11.	Output voltage drop limitation	16
Figure 12.	Device behavior in overload condition	17
Figure 13.	Off-state output current	19
Figure 14.	High level input current	19
Figure 15.	Input clamp voltage	19
Figure 16.	Input low level voltage	19
Figure 17.	Input high level voltage	19
Figure 18.	Input hysteresis voltage	19
Figure 19.	On state resistance vs T_{case}	20
Figure 20.	On state resistance vs V_{CC}	20
Figure 21.	I_{LIMH} vs T_{case}	20
Figure 22.	Turn-On voltage slope	20
Figure 23.	Turn-Off voltage slope	20
Figure 24.	Application schematic	21
Figure 25.	Maximum turn-off current versus inductance	22
Figure 26.	PowerSO-10 PC board	23
Figure 27.	$R_{\text{thj-amb}}$ vs PCB copper area in open box free air condition (one channel on)	23
Figure 28.	PowerSO-10 thermal impedance junction ambient single pulse (one channel on)	24
Figure 29.	Thermal fitting model of a double channel HSD in PowerSO-10	24
Figure 30.	PowerSO-10 package dimensions	26
Figure 31.	PowerSO-10 suggested pad layout and tube shipment (no suffix)	28
Figure 32.	PowerSO-10 tape and reel shipment (suffix "TR")	28

1 Block diagram and pin description

Figure 1. Block diagram

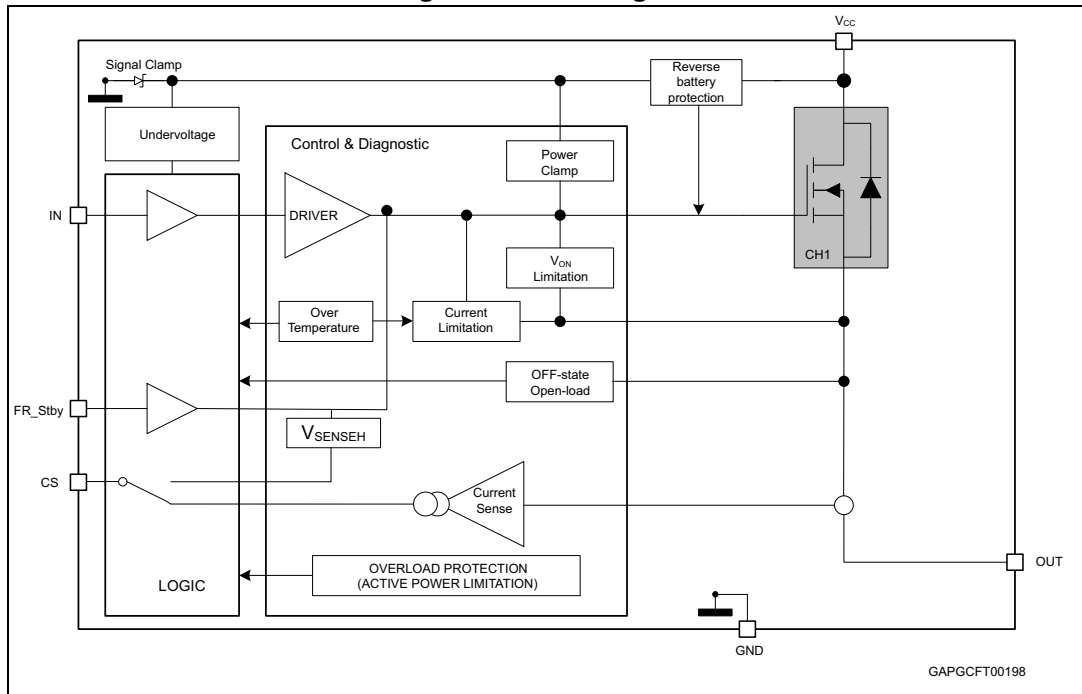

Table 1. Pin function

Name	Function
V _{CC}	Battery connection.
OUT	Power output.
GND	Ground connection.
IN	Voltage controlled input pin with hysteresis, CMOS compatible; it controls output switch state.
CS	Analog current sense pin; it delivers a current proportional to the load current.
FR_Stby	In case of latch-off for overtemperature /overcurrent condition, a low pulse on the FR_Stby pin is needed to reset the channel. The device enters in standby mode if all inputs and the FR_Stby pin are low.

Figure 2. Configuration diagram (top view)

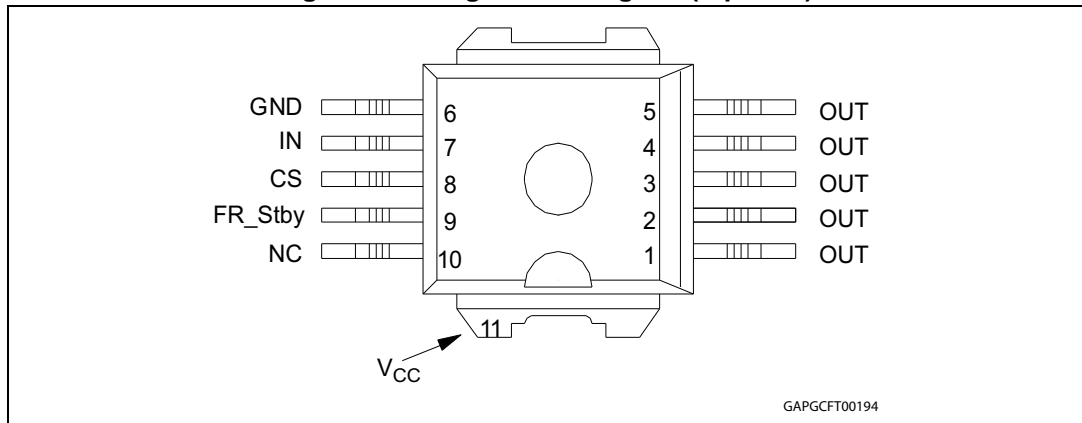

Table 2. Suggested connections for unused and not connected pins

Connection / pin	CS	N.C.	OUT	IN	FR_Stby
Floating	Not allowed	X ⁽¹⁾	X	X	X
To ground	Through 10 KΩ resistor	X	Not allowed	Through 10 KΩ resistor	Through 10 KΩ resistor

1. X: do not care.

2 Electrical specifications

Figure 3. Current and voltage conventions

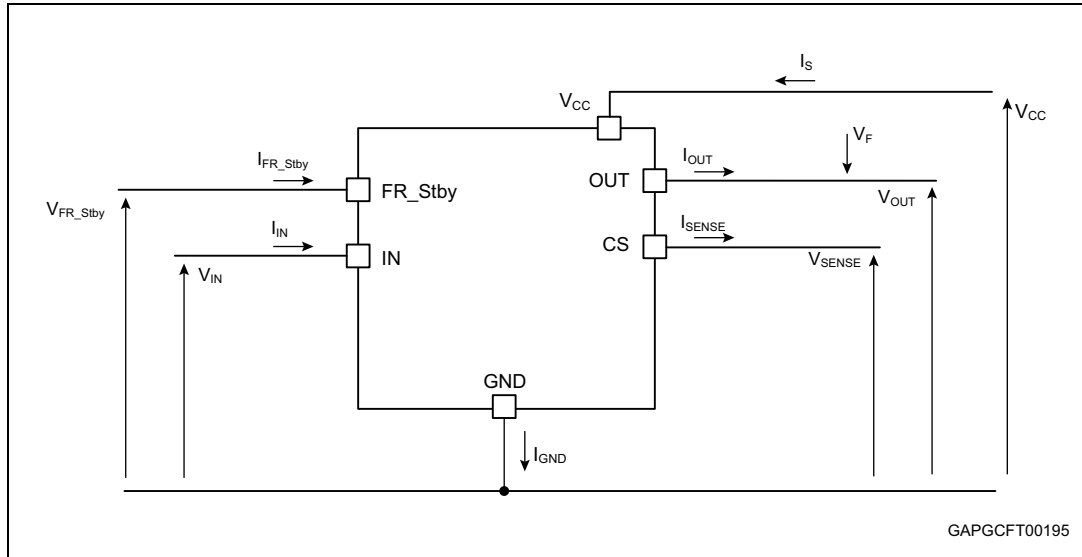

2.1 Absolute maximum ratings

Stressing the device above the ratings listed in [Table 3](#) may cause permanent damage to the device. These are stress ratings only and operation of the device at these or any other conditions above those indicated in the operating sections of this specification is not implied. Exposure to the conditions reported in this section for extended periods may affect device reliability.

Table 3. Absolute maximum ratings

Symbol	Parameter	Value	Unit
V _{CC}	DC supply voltage	58	V
-V _{CC}	Reverse DC supply voltage	-32	V
I _{OUT}	DC output current	Internally limited	A
-I _{OUT}	Reverse DC output current	90	A
I _{IN}	DC input current	-1 to 10	mA
I _{FR_Stby}	Fault reset standby DC input current	-1 to 1.5	mA
V _{CSSENSE}	Current sense maximum voltage	V _{CC} - 58 to +V _{CC}	V
E _{MAX}	Maximum switching energy (L = 10 mH; V _{bat} = 32 V; T _{jstart} = 150°C; I _{OUT} = 8.9 A)	880	mJ
L _{SMAX}	Maximum stray inductance in short circuit condition V _{bat} = 32 V; R _L = 300 mΩ; T _{jstart} = 150°C; I _{OUT} = I _{limH_max}	40	μH

Table 3. Absolute maximum ratings (continued)

Symbol	Parameter	Value	Unit
V _{ESD}	Electrostatic discharge (human body model: R = 1.5 KΩ; C = 100 pF)		
	– IN	4000	V
	– CS	2000	V
	– FR_Stby	4000	V
	– OUT	5000	V
	– V _{CC}	5000	V
V _{ESD}	Charge device model (CDM-AEC-Q100-011)	750	V
T _j	Junction operating temperature	-40 to 150	°C
T _{stg}	Storage temperature	-55 to 150	°C

2.2 Thermal data

Table 4. Thermal data

Symbol	Parameter	Value	Unit
R _{thj-case}	Thermal resistance junction-case (max.) (with one channel on)	0.8	°C/W
R _{thj-amb}	Thermal resistance junction-ambient (max.)	See Figure 27	°C/W

2.3 Electrical characteristics

$8\text{ V} < V_{CC} < 36\text{ V}$; $-40^\circ\text{C} < T_j < 150^\circ\text{C}$, unless otherwise specified.

Table 5. Power section

Symbol	Parameter	Test conditions	Min.	Typ.	Max.	Unit
V_{CC}	Operating supply voltage		8	24	36	V
V_{USD}	Undervoltage shutdown			3.5	5	V
$V_{USDhyst}$	Undervoltage shutdown hysteresis			0.5		V
R_{ON}	On-state resistance ⁽²⁾	$I_{OUT} = 10\text{ A}$; $T_j = 25^\circ\text{C}$; $8\text{ V} < V_{CC} < 36\text{ V}$		6		m Ω
		$I_{OUT} = 10\text{ A}$; $T_j = 150^\circ\text{C}$; $8\text{ V} < V_{CC} < 36\text{ V}$			12	
$R_{ON REV}$	Reverse battery on-state resistance	$V_{CC} = -24\text{ V}$; $I_{OUT} = -10\text{ A}$; $T_j = 25^\circ\text{C}$			6	m Ω
V_{clamp}	Clamp voltage	$I_S = 20\text{ mA}$	58	64	70	V
I_S	Supply current	Off-state: $V_{CC} = 24\text{ V}$; $T_j = 25^\circ\text{C}$; $V_{IN} = V_{OUT} = V_{SENSE} = 0\text{ V}$		2 ⁽¹⁾	5	μA
		On-state: $V_{CC} = 24\text{ V}$; $V_{IN} = 5\text{ V}$; $I_{OUT} = 0\text{ A}$		3	6	mA
$I_{L(off1)}$	Off-state output current	$V_{IN} = V_{OUT} = 0\text{ V}$; $V_{CC} = 24\text{ V}$; $T_j = 25^\circ\text{C}$	0	0.01	3	μA
		$V_{IN} = V_{OUT} = 0\text{ V}$; $V_{CC} = 24\text{ V}$; $T_j = 125^\circ\text{C}$	0		5	

1. PowerMOS leakage included.

Table 6. Switching ($V_{CC} = 24\text{ V}$; $T_j = 25^\circ\text{C}$)

Symbol	Parameter	Test conditions	Min.	Typ.	Max.	Unit
$t_{d(on)}$	Turn-on delay time	$R_L = 2.4\ \Omega$	—	32	—	μs
$t_{d(off)}$	Turn-off delay time	$R_L = 2.4\ \Omega$	—	67	—	μs
$dV_{OUT}/dt_{(on)}$	Turn-on voltage slope	$R_L = 2.4\ \Omega$		0.7		V/ μs
$dV_{OUT}/dt_{(off)}$	Turn-off voltage slope	$R_L = 2.4\ \Omega$		0.46		V/ μs
W_{ON}	Switching energy losses during t_{won}	$R_L = 2.4\ \Omega$	—	4.15	—	mJ
W_{OFF}	Switching energy losses during t_{woff}	$R_L = 2.4\ \Omega$	—	2.7	—	mJ

Table 7. Logic inputs

Symbol	Parameter	Test conditions	Min.	Typ.	Max.	Unit
V_{IL}	Low-level input voltage				0.9	V
I_{IL}	Low-level input current	$V_{IN} = 0.9\text{ V}$	1			μA
V_{IH}	High-level input voltage		2.1			V
I_{IH}	High-level input current	$V_{IN} = 2.1\text{ V}$			10	μA
$V_{I(hyst)}$	Input hysteresis voltage		0.25			V
V_{ICL}	Input clamp voltage	$I_{IN} = 1\text{ mA}$	5.5		7	V
		$I_{IN} = -1\text{ mA}$		-0.7		
$V_{FR_Stby_L}$	Low-level fault-reset-standby voltage				0.9	V
$I_{FR_Stby_L}$	Low-level fault-reset-standby current	$V_{FR_Stby} = 0.9\text{ V}$	1			μA
$V_{FR_Stby_H}$	High-level fault-reset-standby voltage		2.1			V
$I_{FR_Stby_H}$	High-level fault-reset-standby current	$V_{FR_Stby} = 2.1\text{ V}$			10	μA
$V_{FR_Stby(hyst)}$	Fault-reset-standby hysteresis voltage		0.25			V
$V_{FR_Stby_CL}$	Fault-reset-standby clamp voltage	$I_{FR_Stby} = 15\text{ mA (10 ms)}$	11		15	V
		$I_{FR_Stby} = -1\text{ mA}$		-0.7		
t_{reset}	Overload latch-off reset time	See Figure 4	2		24	μs
t_{stby}	Standby delay	See Figure 5	120		1200	μs

Figure 4. T_{reset} definition

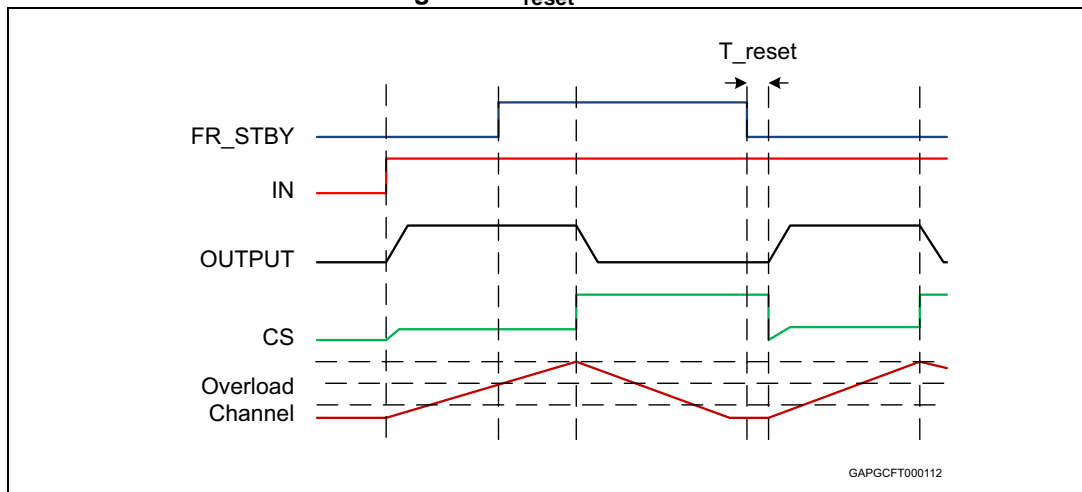

Figure 5. T_{stby} definition

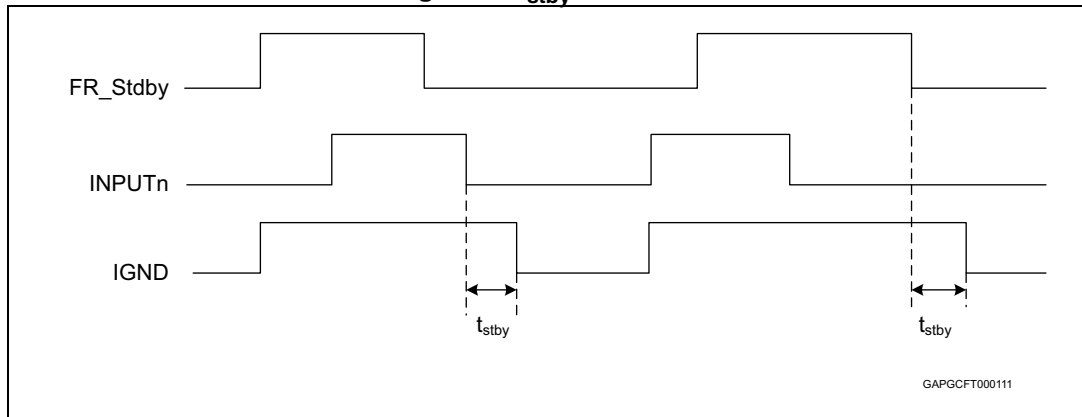

Table 8. Protections and diagnostics

Symbol	Parameter	Test conditions	Min.	Typ.	Max.	Unit
I_{limH}	DC short-circuit current	$V_{CC} = 24\text{ V}$	81	115	162	A
		$5\text{ V} < V_{CC} < 36\text{ V}$			162	A
I_{limL}	Short-circuit current during thermal cycling	$V_{CC} = 24\text{ V}; T_R < T_j < T_{TSD}$		29		A
T_{TSD}	Shutdown temperature		150	175	200	$^{\circ}\text{C}$
T_R	Reset temperature		$T_{RS} + 1$	$T_{RS} + 5$		$^{\circ}\text{C}$
T_{RS}	Thermal reset of status		135			$^{\circ}\text{C}$
T_{HYST}	Thermal hysteresis ($T_{TSD} - T_R$)			7		$^{\circ}\text{C}$
V_{DEMAG}	Turn-off output voltage clamp	$I_{OUT} = 10\text{ A}; V_{IN} = 0\text{ V}; L = 6\text{ mH}$	$V_{CC} - 58$	$V_{CC} - 64$	$V_{CC} - 70$	V
V_{ON}	Output voltage drop limitation	$I_{OUT} = 1\text{ A}; T_j = -40^{\circ}\text{C} \text{ to } 150^{\circ}\text{C}$		25		mV

Table 9. Current sense ($8\text{ V} < V_{CC} < 36\text{ V}$)

Symbol	Parameter	Test conditions	Min.	Typ.	Max.	Unit
K_0	I_{OUT}/I_{SENSE}	$I_{OUT} = 0.6\text{ A}$; $V_{SENSE} = 0.5\text{ V}$; $T_j = -40^\circ\text{C}$ to 150°C $T_j = 25^\circ\text{C}$ to 150°C	3930 5035	11250	19850 17055	
$dK_0/K_0^{(1)}$	Current sense ratio drift	$I_{OUT} = 0.6\text{ A}$; $V_{SENSE} = 0.5\text{ V}$; $T_j = -40^\circ\text{C}$ to 150°C	-30		30	%
K_1	I_{OUT}/I_{SENSE}	$I_{OUT} = 1.6\text{ A}$; $V_{SENSE} = 1\text{ V}$; $T_j = -40^\circ\text{C}$ to 150°C ; $T_j = 25^\circ\text{C}$ to 150°C	5600 6215	10750	16940 14660	
$dK_1/K_1^{(1)}$	Current sense ratio drift	$I_{OUT} = 1.6\text{ A}$; $V_{SENSE} = 1\text{ V}$; $T_j = -40^\circ\text{C}$ to 150°C	-28		25	%
K_2	I_{OUT}/I_{SENSE}	$I_{OUT} = 2.4\text{ A}$; $V_{SENSE} = 1\text{ V}$; $T_j = -40^\circ\text{C}$ to 150°C $T_j = 25^\circ\text{C}$ to 150°C	6030 6200	10370	15865 13635	
$dK_2/K_2^{(1)}$	Current sense ratio drift	$I_{OUT} = 2.4\text{ A}$; $V_{SENSE} = 1\text{ V}$; $T_j = -40^\circ\text{C}$ to 150°C	-26		23	%
K_3	I_{OUT}/I_{SENSE}	$I_{OUT} = 3\text{ A}$; $V_{SENSE} = 2\text{ V}$; $T_j = -40^\circ\text{C}$ to 150°C $T_j = 25^\circ\text{C}$ to 150°C	6040 6040	10070	15285 13090	
$dK_3/K_3^{(1)}$	Current sense ratio drift	$I_{OUT} = 3\text{ A}$; $V_{SENSE} = 2\text{ V}$; $T_j = -40^\circ\text{C}$ to 150°C	-25		22	%
K_4	I_{OUT}/I_{SENSE}	$I_{OUT} = 6\text{ A}$; $V_{SENSE} = 4\text{ V}$; $T_j = -40^\circ\text{C}$ to 150°C $T_j = 25^\circ\text{C}$ to 150°C	5845 6000	8670	13630 10895	
$dK_4/K_4^{(1)}$	Current sense ratio drift	$I_{OUT} = 6\text{ A}$; $V_{SENSE} = 4\text{ V}$; $T_j = -40^\circ\text{C}$ to 150°C	-20		20	%
K_5	I_{OUT}/I_{SENSE}	$I_{OUT} = 10\text{ A}$; $V_{SENSE} = 4\text{ V}$; $T_j = -40^\circ\text{C}$ to 150°C $T_j = 25^\circ\text{C}$ to 150°C	5920 6730	8400	11520 9765	
$dK_5/K_5^{(1)}$	Current sense ratio drift	$I_{OUT} = 10\text{ A}$; $V_{SENSE} = 4\text{ V}$; $T_j = -40^\circ\text{C}$ to 150°C	-15		15	%
K_6	I_{OUT}/I_{SENSE}	$I_{OUT} = 20\text{ A}$; $V_{SENSE} = 4\text{ V}$; $T_j = -40^\circ\text{C}$ to 150°C	6960	8330	10090	
$dK_6/K_6^{(1)}$	Current sense ratio drift	$I_{OUT} = 3\text{ A}$; $V_{SENSE} = 2\text{ V}$; $T_j = -40^\circ\text{C}$ to 150°C	-8		8	%
$dK/K_{BULB1}^{(1)}$	Current sense ratio drift	$I_{OUT} = 0.6\text{ A}$ to 6 A ; $I_{CAL} = 3\text{ A}$; $V_{SENSE} = 0.5\text{ V}$; $T_j = -40^\circ\text{C}$ to 150°C	-30		50	%
$dK/K_{BULB2}^{(1)}$	Current sense ratio drift	$I_{OUT} = 1.6\text{ A}$ to 4.2 A ; $I_{OUTCAL} = 3\text{ A}$; $V_{SENSE} = 2\text{ V}$; $T_j = -40^\circ\text{C}$ to 150°C	-30		26	%
$dK/K_{BULB3}^{(1)}$	Current sense ratio drift	$I_{OUT} = 0.6\text{ A}$ to 2.4 A ; $I_{OUTCAL} = 1.6\text{ A}$; $V_{SENSE} = 2\text{ V}$; $T_j = -40^\circ\text{C}$ to 150°C	-27		25	%

Table 9. Current sense (8 V < V_{CC} < 36 V) (continued)

Symbol	Parameter	Test conditions	Min.	Typ.	Max.	Unit
I _{SENSE0}	Analog sense leakage current	I _{OUT} = 0 A; V _{SENSE} = 0 V; V _{IN} = 0 V; T _j = -40°C to 150°C	0		1	μA
		I _{OUT} = 0 A; V _{SENSE} = 0 V; V _{IN} = 5 V; T _j = -40°C to 150°C	0		2	
V _{SENSE}	Max analog sense output voltage	I _{OUT} = 40 A; R _{SENSE} = 3.9 KΩ	5			V
V _{SENSEH}	Analog sense output voltage in fault condition ⁽²⁾	V _{CC} = 24 V; R _{SENSE} = 3.9 KΩ		8		V
I _{SENSEH}	Analog sense output current in fault condition ⁽²⁾	V _{CC} = 24 V; V _{SENSE} = 5 V		9	12	mA
t _{DSENSE2H}	Delay response time from rising edge of IN pin	V _{SENSE} < 4 V; 1 A < I _{OUT} < 40 A; I _{SENSE} = 90% of I _{SENSEMAX} (see Figure 7)		300	600	μs
Δt _{DSENSE2H}	Delay response time between rising edge of output current and rising edge of current sense	V _{SENSE} < 4 V; I _{SENSE} = 90% of I _{SENSEMAX} , I _{OUT} = 90% of I _{OUTMAX} I _{OUTMAX} = 10 A (see Figure 10)			450	μs
t _{DSENSE2L}	Delay response time from falling edge of IN pin	V _{SENSE} < 4 V; 1 A < I _{OUT} < 40 A; I _{SENSE} = 10 % of I _{SENSEMAX} (see Figure 7)		5	20	μs

- Parameter guaranteed by design; it is not tested.
- Fault condition includes: power limitation, overtemperature and open-load in OFF-state condition.

Table 10. Open-load detection (FR_Stby = 5 V)

Symbol	Parameter	Test conditions	Min.	Typ.	Max.	Unit
V _{OL}	Open-load Off-state voltage detection threshold	V _{IN} = 0 V; 8 V < V _{CC} < 36 V	2		4	V
t _{DSTKON}	Output short-circuit to V _{CC} detection delay at turn-off	See Figure 8	180		1800	μs
I _{L(off2)}	Off-state output current at V _{OUT} = 4 V	V _{IN} = 0 V; V _{SENSE} = 0 V; V _{OUT} rising from 0 V to 4 V	-120		0	μA

Table 10. Open-load detection (FR_Stby = 5 V) (continued)

Symbol	Parameter	Test conditions	Min.	Typ.	Max.	Unit
t_{d_vol}	Delay response from output rising edge to V_{SENSE} rising edge in open-load	$V_{OUT} = 4\text{ V}$; $V_{IN} = 0\text{ V}$; $V_{SENSE} = 90\%$ of V_{SENSEH}			20	μs
t_{DFRSTK_ON}	Output short circuit to V_{CC} detection delay at FR_{STBY} activation	See Figure 6; Input _{1,2} = low			50	μs

Figure 6. Output stuck to V_{CC} detection delay time at FR_{STBY} activation

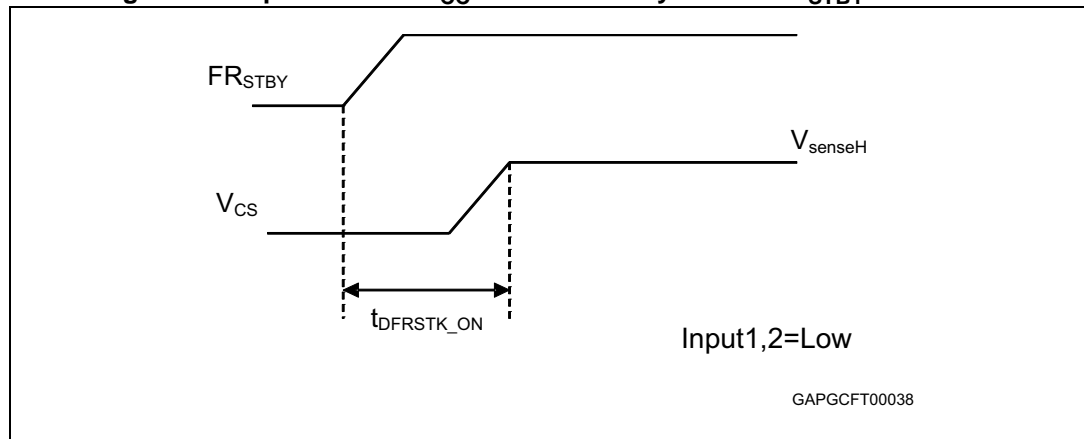

Figure 7. Current sense delay characteristics

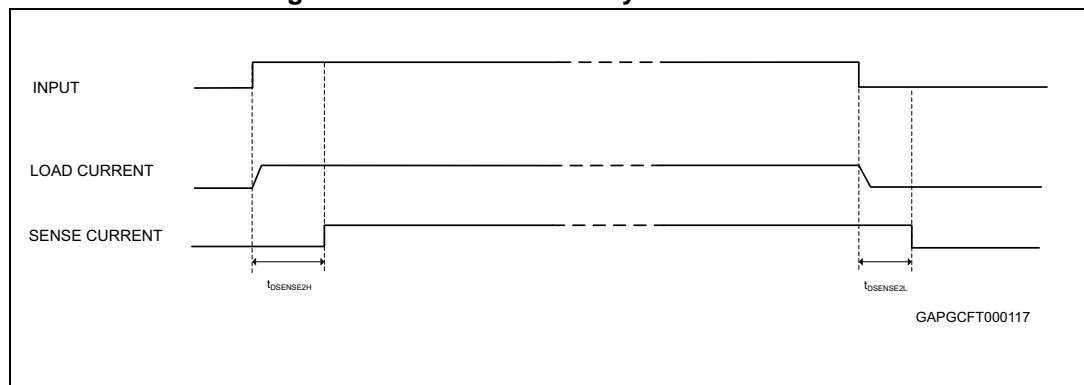

Figure 8. Open-load off-state delay timing

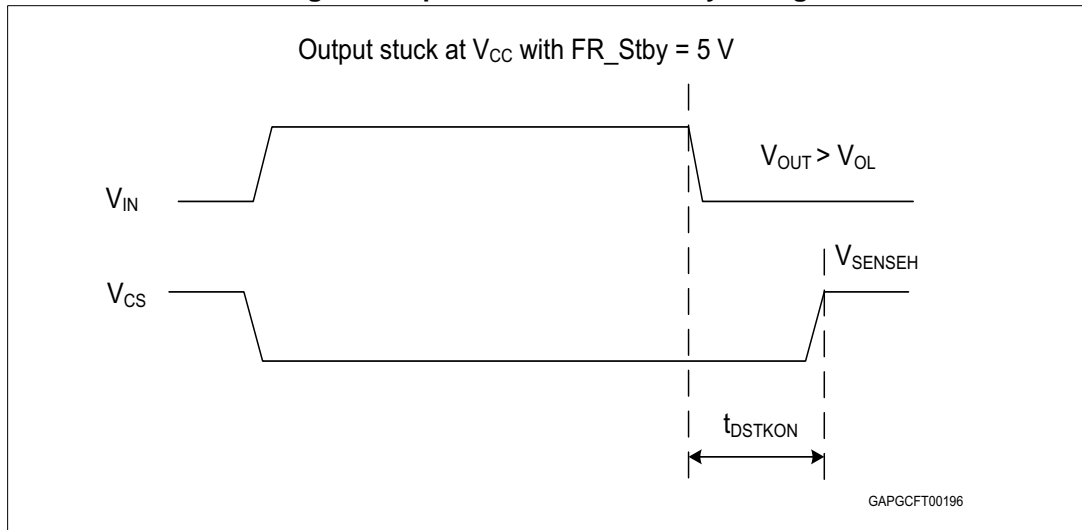

Figure 9. Switching characteristics

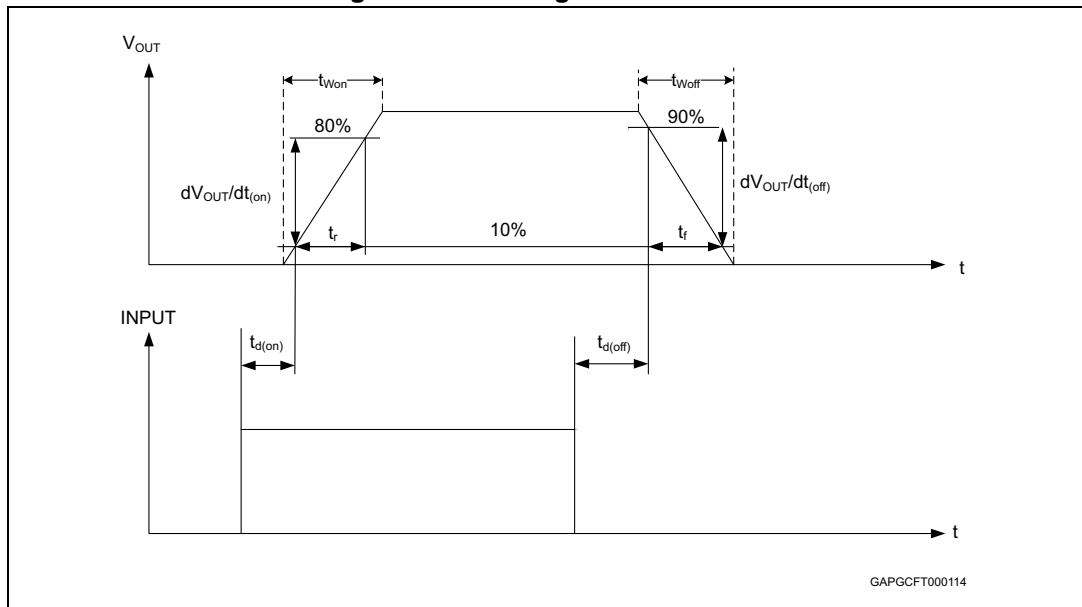

Figure 10. Delay response time between rising edge of output current and rising edge of current sense

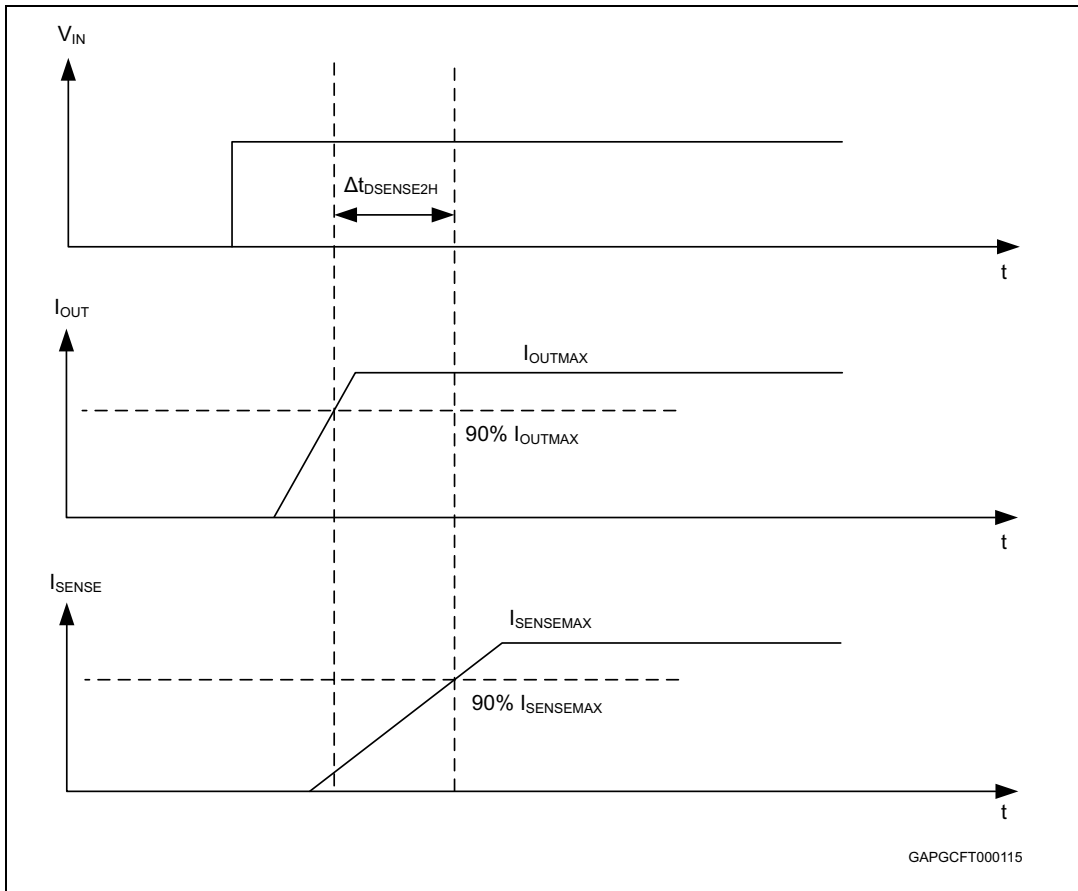

Figure 11. Output voltage drop limitation

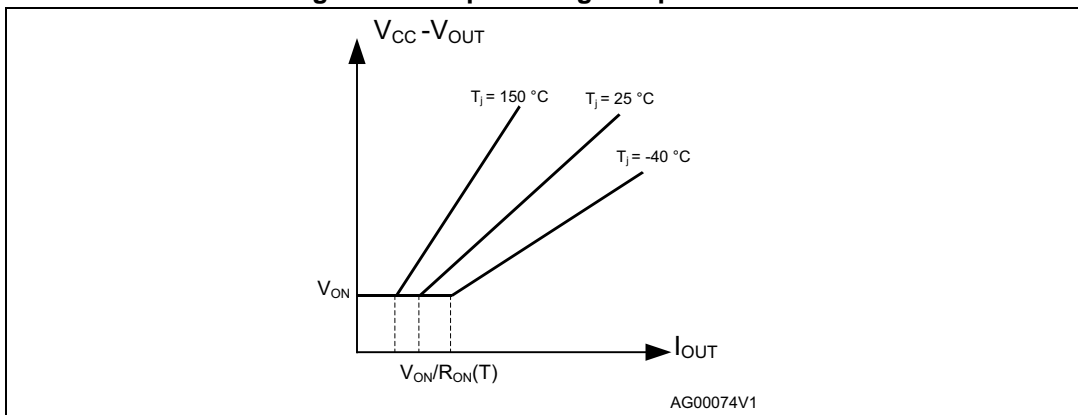

Figure 12. Device behavior in overload condition

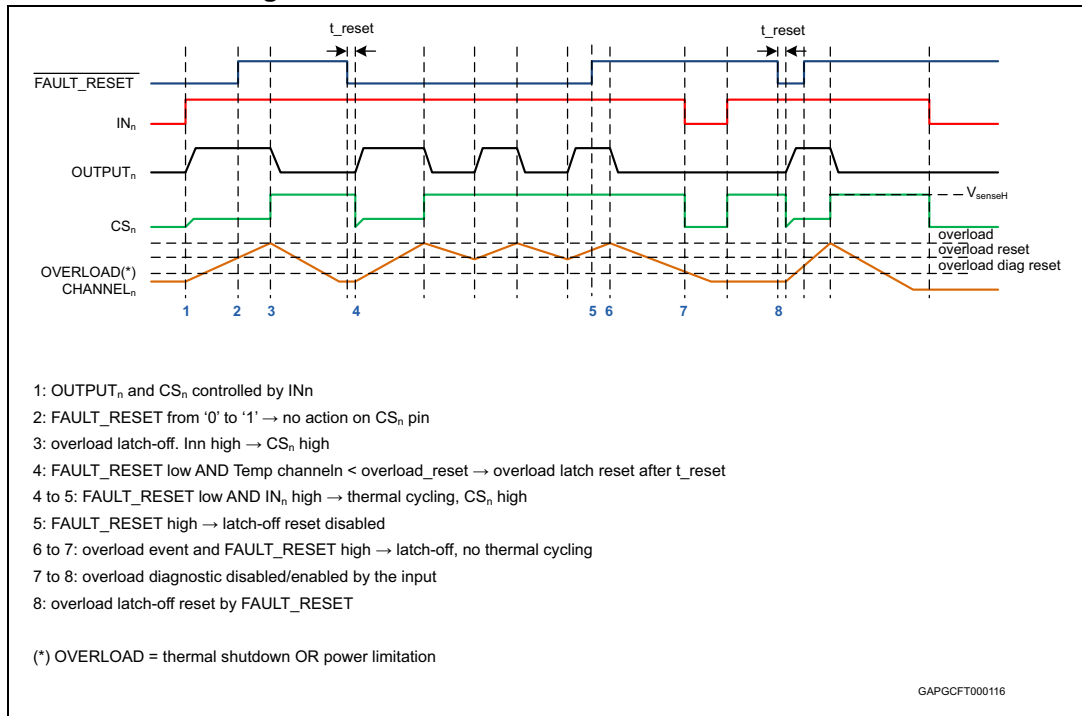

Table 11. Truth table

Conditions	Fault reset standby	Input	Output	Sense
Standby	L	L	X	0
Normal operation	X	L	L	0
	X	H	H	Nominal
Overload	X	L	L	0
	X	H	H	> Nominal
Overtemperature / short to ground	X	L	L	0
	L H	H H	Cycling Latched	V _{SENSEH} V _{SENSEH}
Undervoltage	X	X	L	0
Short to V _{BAT}	L	L	H	0
	H X	L H	H H	V _{SENSEH} < Nominal
Open-load Off-state (with pull-up)	L	L	H	0
	H	L	H	V _{SENSEH}
	X	H	H	0
Negative output voltage clamp	X	L	Negative	0

Table 12. Electrical transient requirements (part 1)

ISO 7637-2: 2004(E) Test pulse	Test levels ⁽¹⁾		Number of pulses or test times	Burst cycle/pulse repetition time		Delays and impedance
	III	IV				
1	- 450 V	- 600 V	5000 pulses	0.5 s	5 s	1 ms, 50 Ω
2a	+ 37 V	+ 50 V	5000 pulses	0.2 s	5 s	50 μs, 2 Ω
3a	- 150 V	- 200 V	1h	90 ms	100 ms	0.1 μs, 50 Ω
3b	+ 150 V	+ 200 V	1h	90 ms	100 ms	0.1 μs, 50 Ω
4	- 12 V	- 16 V	1 pulse			100 ms, 0.01 Ω
5b ⁽²⁾	+ 123 V	+ 174 V	1 pulse			350 ms, 1 Ω

1. The above test levels must be considered referred to $V_{CC} = 24.5V$ except for pulse 5b
2. Valid in case of external load dump clamp: 58V maximum referred to ground.

Table 13. Electrical transient requirements (part 2)

ISO 7637-2: 2004(E) Test pulse	Test level results	
	III	IV
1	C	C ⁽¹⁾
2a	C	C
3a	C	C
3b ⁽²⁾	E	E
3b ⁽³⁾	C	C
4	C	C
5b ⁽⁴⁾	C	C

1. With $R_{LOAD} < 24 \Omega$.
2. Without capacitor between V_{CC} and GND.
3. With 10 nF between V_{CC} and GND.
4. External load dump clamp: 58 V maximum, referred to ground.

Table 14. Electrical transient requirements (part 3)

Class	Contents
C	All functions of the device are performed as designed after exposure to disturbance.
E	One or more functions of the device are not performed as designed after exposure to disturbance and cannot be returned to proper operation without replacing the device.

2.4 Electrical characteristics curves

Figure 13. Off-state output current

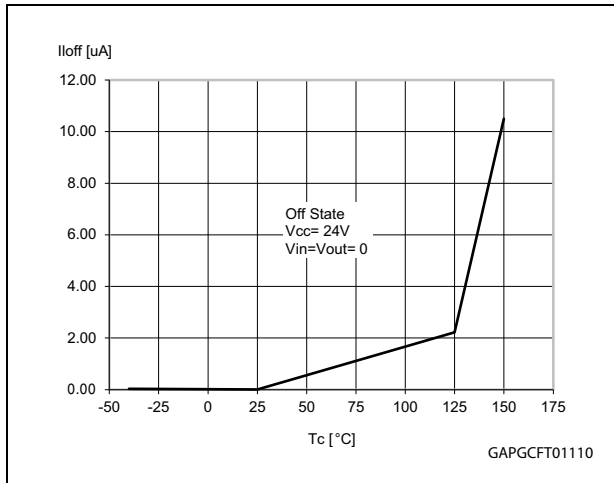

Figure 14. High level input current

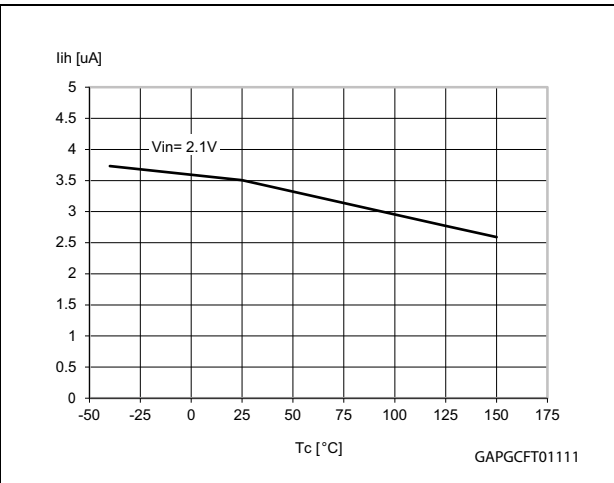

Figure 15. Input clamp voltage

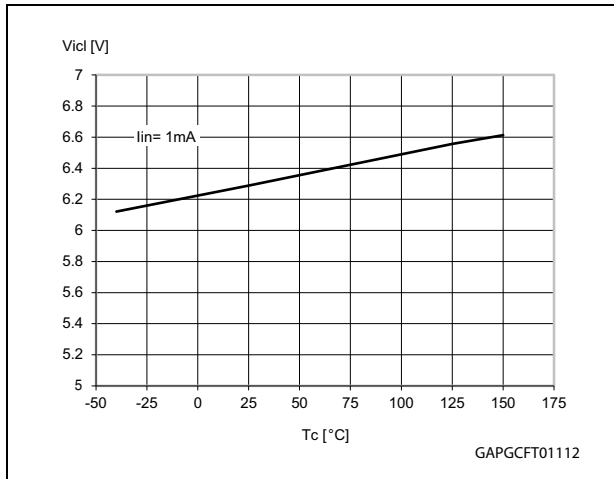

Figure 16. Input low level voltage

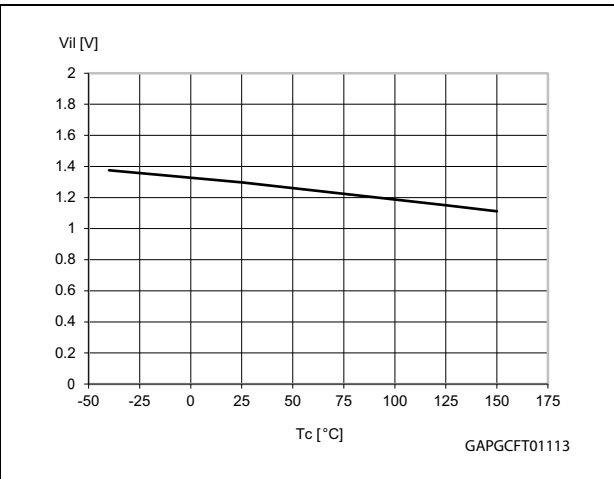

Figure 17. Input high level voltage

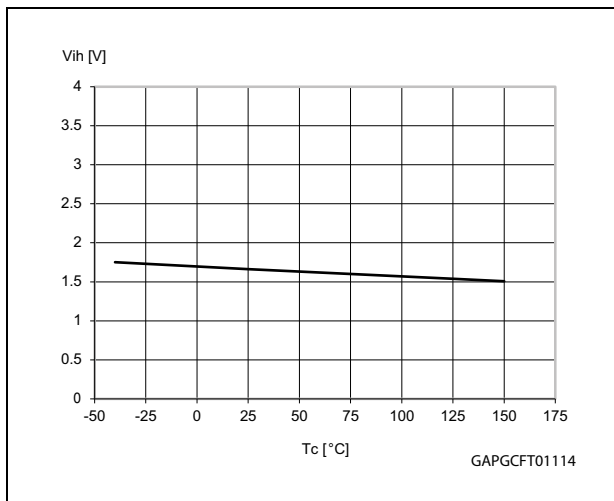

Figure 18. Input hysteresis voltage

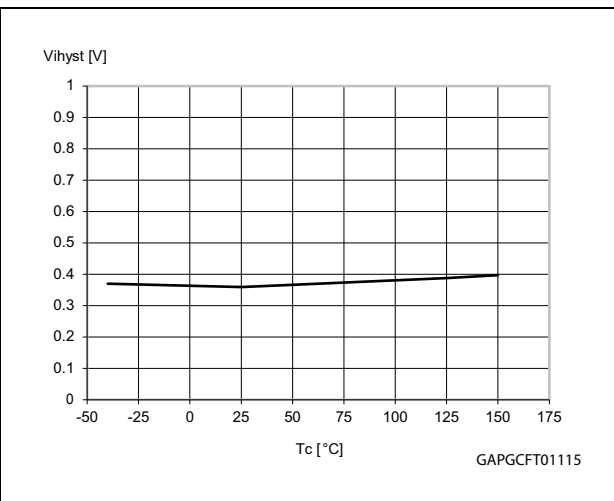

Figure 19. On state resistance vs T_{case}

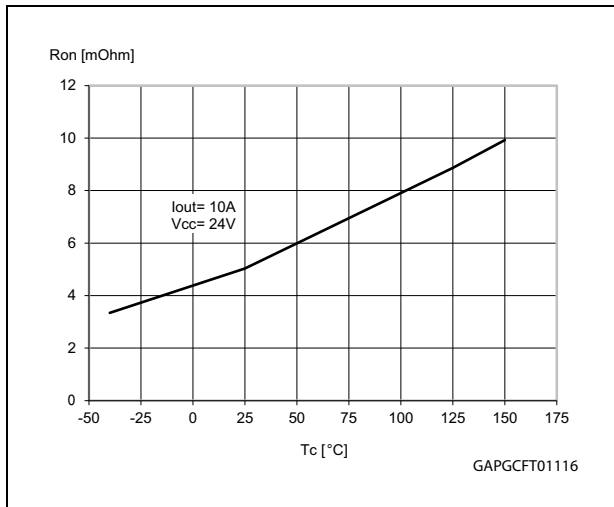

Figure 20. On state resistance vs V_{CC}

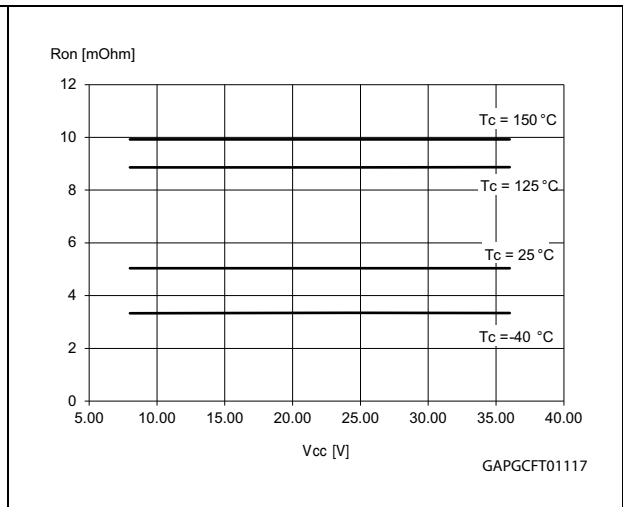

Figure 21. I_{LIMH} vs T_{case}

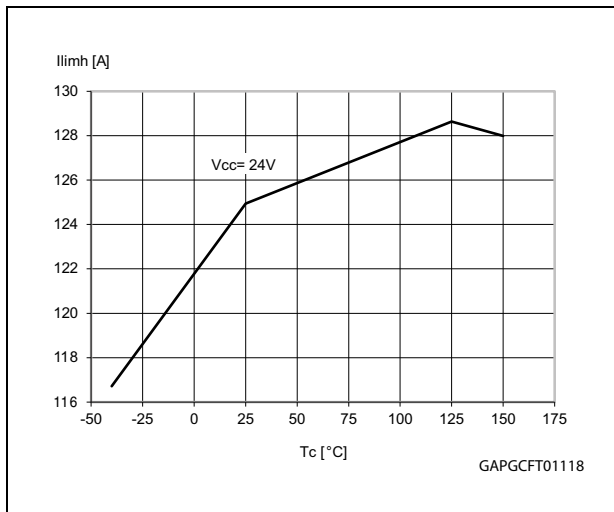

Figure 22. Turn-On voltage slope

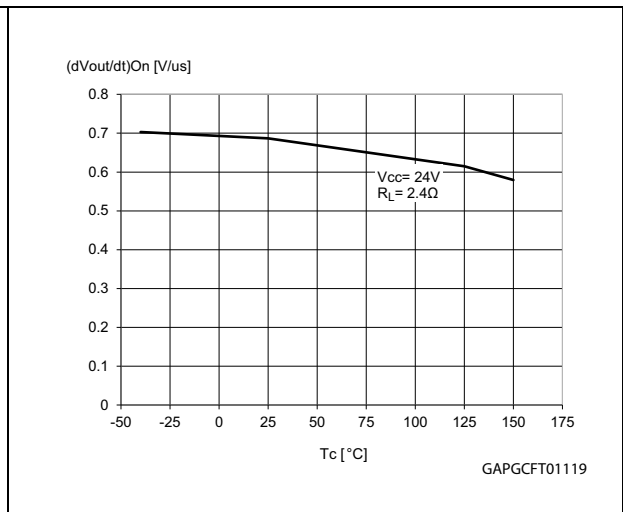
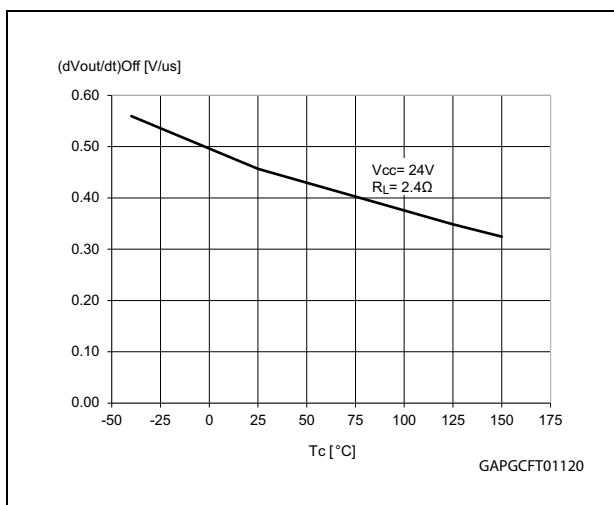
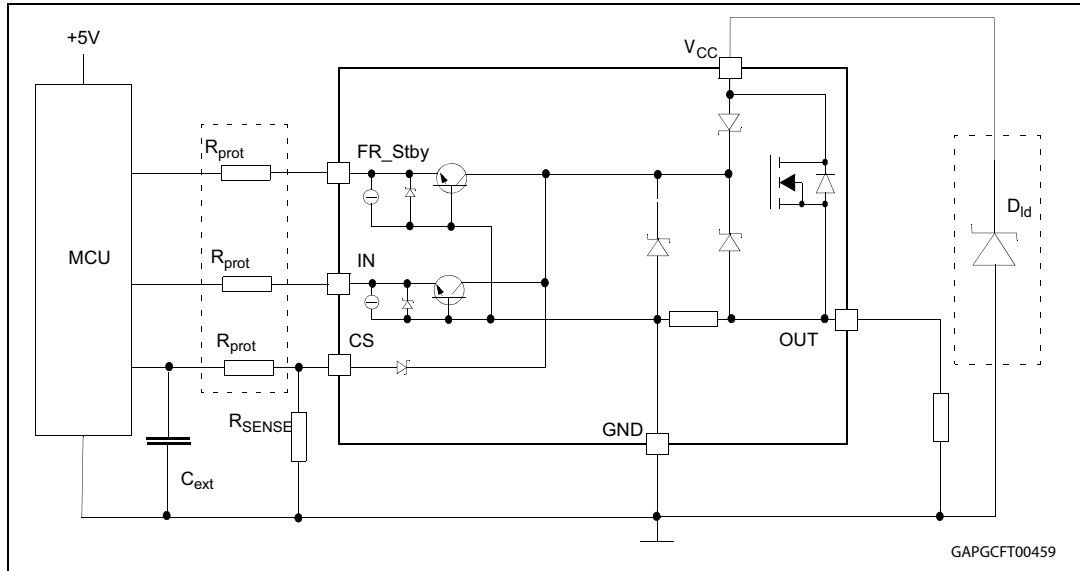

Figure 23. Turn-Off voltage slope



3 Application information

Figure 24. Application schematic



3.1 Load dump protection

D_{id} is necessary (voltage transient suppressor) if the load dump peak voltage exceeds the V_{CC} max DC rating. The same applies if the device is subject to transients on the V_{CC} line that are greater than the ones shown in the ISO 7637-2 2004 (E) table.

3.2 MCU I/Os protection

When negative transients are present on the V_{CC} line, the control pins is pulled negative. ST suggests to insert a resistor (R_{prot}) in line to prevent the microcontroller I/O pins from latching-up.

The value of these resistors is a compromise between the leakage current of microcontroller and the current required by the HSD I/Os (input levels compatibility) with the latch-up limit of microcontroller I/Os.

Equation 1

$$-V_{CCpeak} / I_{latchup} \leq R_{prot} \leq (V_{OH\mu C} - V_{IH}) / I_{IHmax}$$

Calculation example:

For V_{CCpeak} = -600 V and I_{latchup} ≥ 20 mA; V_{OHμC} ≥ 4.5 V

30 kΩ ≤ R_{prot} ≤ 190 kΩ.

Recommended value: R_{prot} = 56 kΩ

3.3 Maximum demagnetization energy ($V_{CC} = 24\text{ V}$)

Figure 25. Maximum turn-off current versus inductance

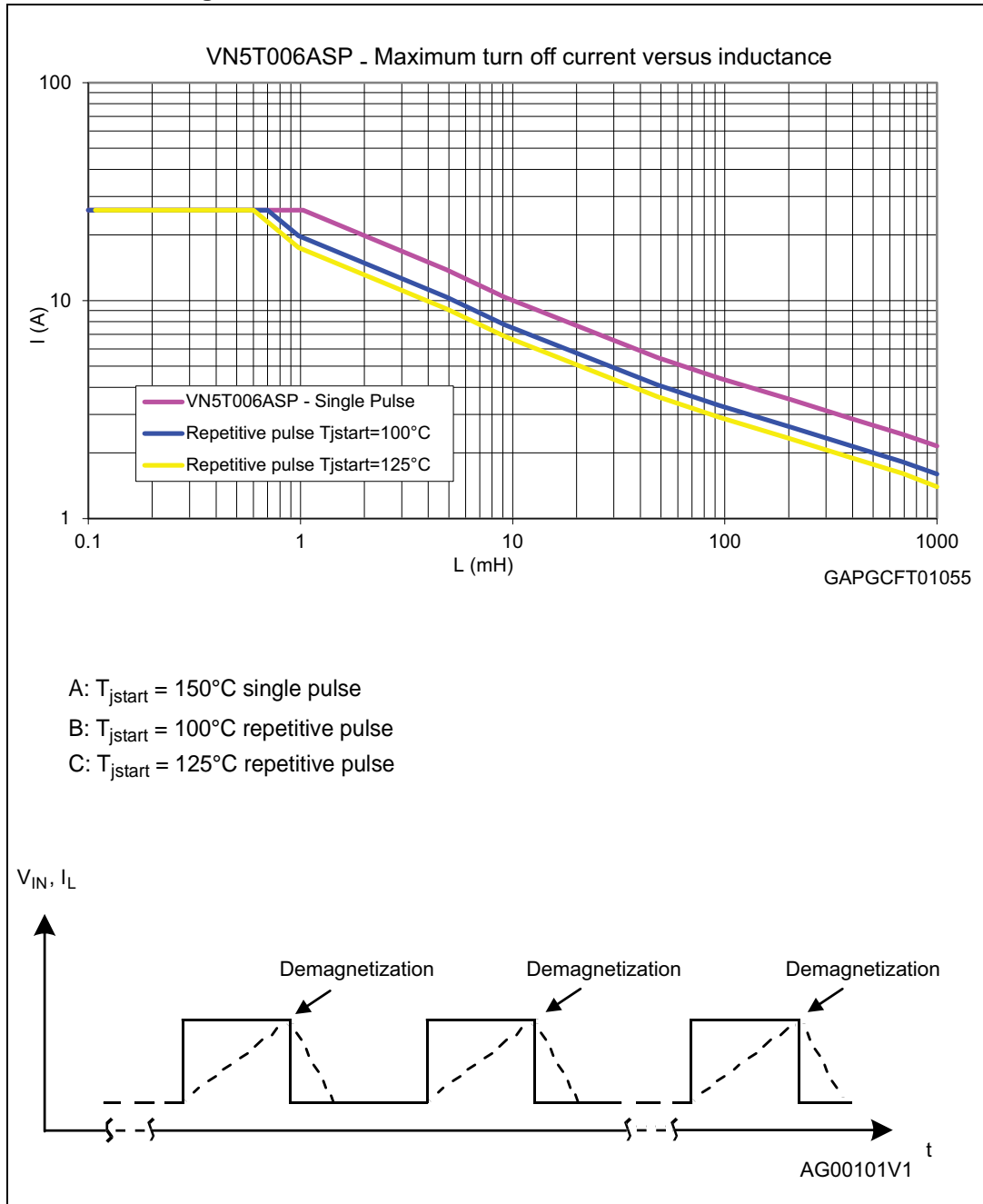

Note: Values are generated with $R_L = 0\ \Omega$.
 In case of repetitive pulses, T_{jstart} (at the beginning of each demagnetization) of every pulse must not exceed the temperature specified above for curves A and B.

4 Package and PCB thermal data

4.1 PowerSO-10 thermal data

Figure 26. PowerSO-10 PC board

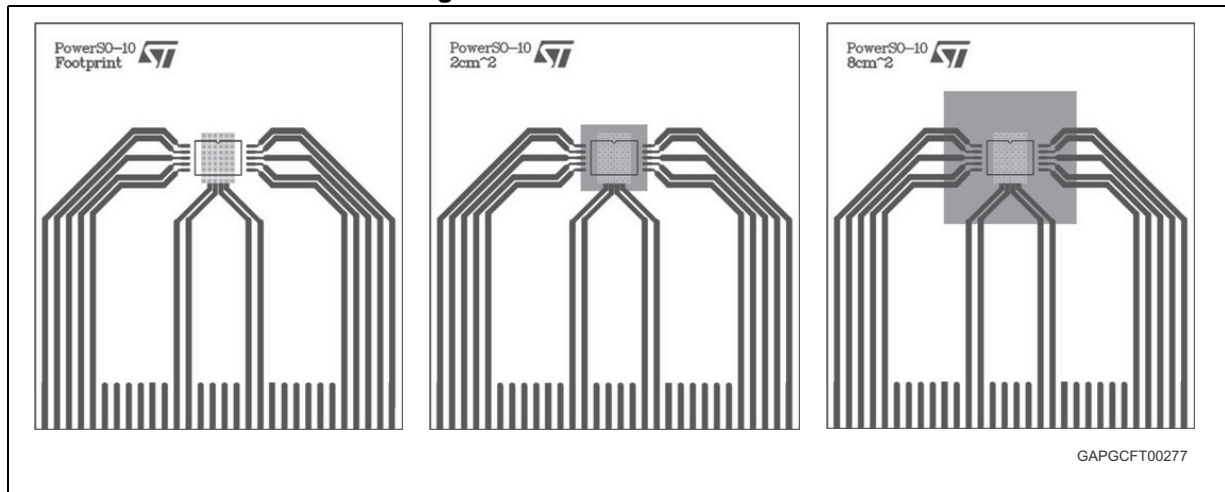

1. Layout condition of R_{th} and Z_{th} measurements (Board finish thickness 1.6 mm +/- 10%; Board double layer; Board dimension 77 x 86; Board Material FR4; Cu thickness 0.070 mm (front and back side); Thermal vias separation 1.2 mm; Thermal via diameter 0.3 mm +/- 0.08 mm; Cu thickness on vias 0.025 mm).

Figure 27. $R_{thj-amb}$ vs PCB copper area in open box free air condition (one channel on)

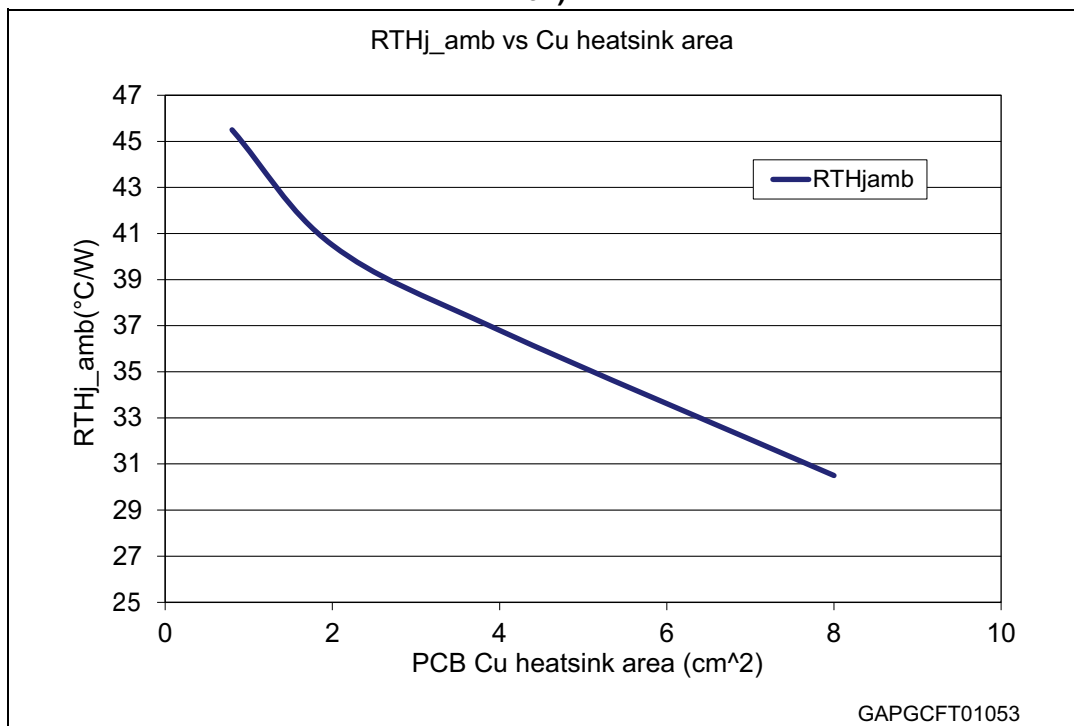

Figure 28. PowerSO-10 thermal impedance junction ambient single pulse (one channel on)

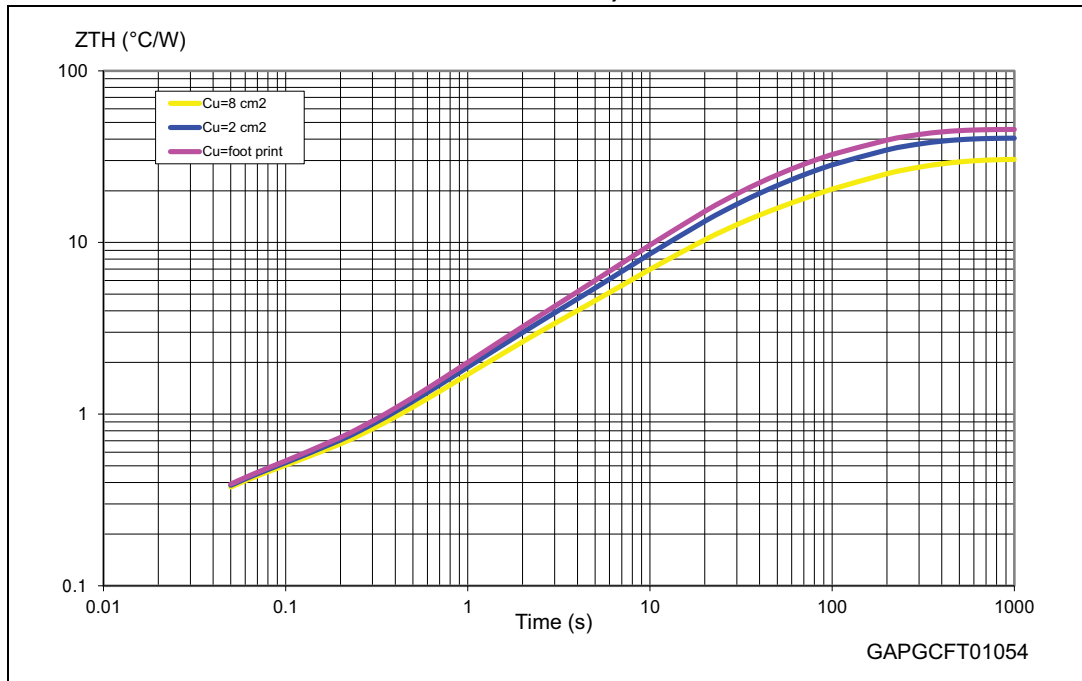
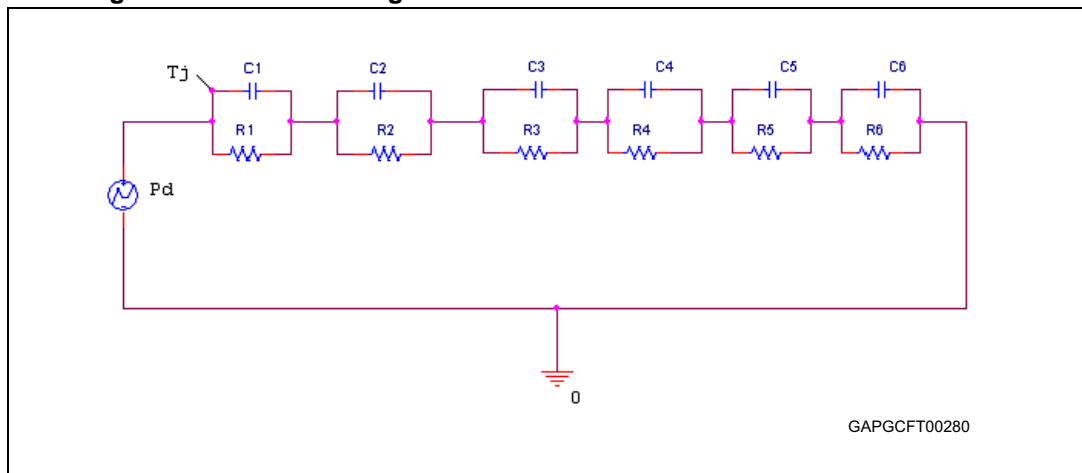

Figure 29. Thermal fitting model of a double channel HSD in PowerSO-10



1. The fitting model is a simplified thermal tool and is valid for transient evolutions where the embedded protections (power limitation or thermal cycling during thermal shutdown) are not triggered.

Equation 2: pulse calculation formula

$$Z_{TH\delta} = R_{TH} \cdot \delta + Z_{THtp}(1 - \delta)$$

where $\delta = t_p/T$

Table 15. Thermal parameters

Area/island (cm ²)	Footprint	2	8
R1 (°C/W)	0.05		
R2 (°C/W)	0.3		
R3 (°C/W)	1.2		
R4 (°C/W)	7		
R5 (°C/W)	13	12	8
R6 (°C/W)	24	20	14
C1 (W.s/°C)	0.05		
C2 (W.s/°C)	0.1		
C3 (W.s/°C)	1		
C4 (W.s/°C)	2		
C5 (W.s/°C)	3	4	8
C6 (W.s/°C)	6	8	14

5 Package information

5.1 ECOPACK®

In order to meet environmental requirements, ST offers these devices in different grades of ECOPACK® packages, depending on their level of environmental compliance. ECOPACK® specifications, grade definitions and product status are available at: www.st.com. ECOPACK® is an ST trademark.

5.2 PowerSO-10 mechanical data

Figure 30. PowerSO-10 package dimensions

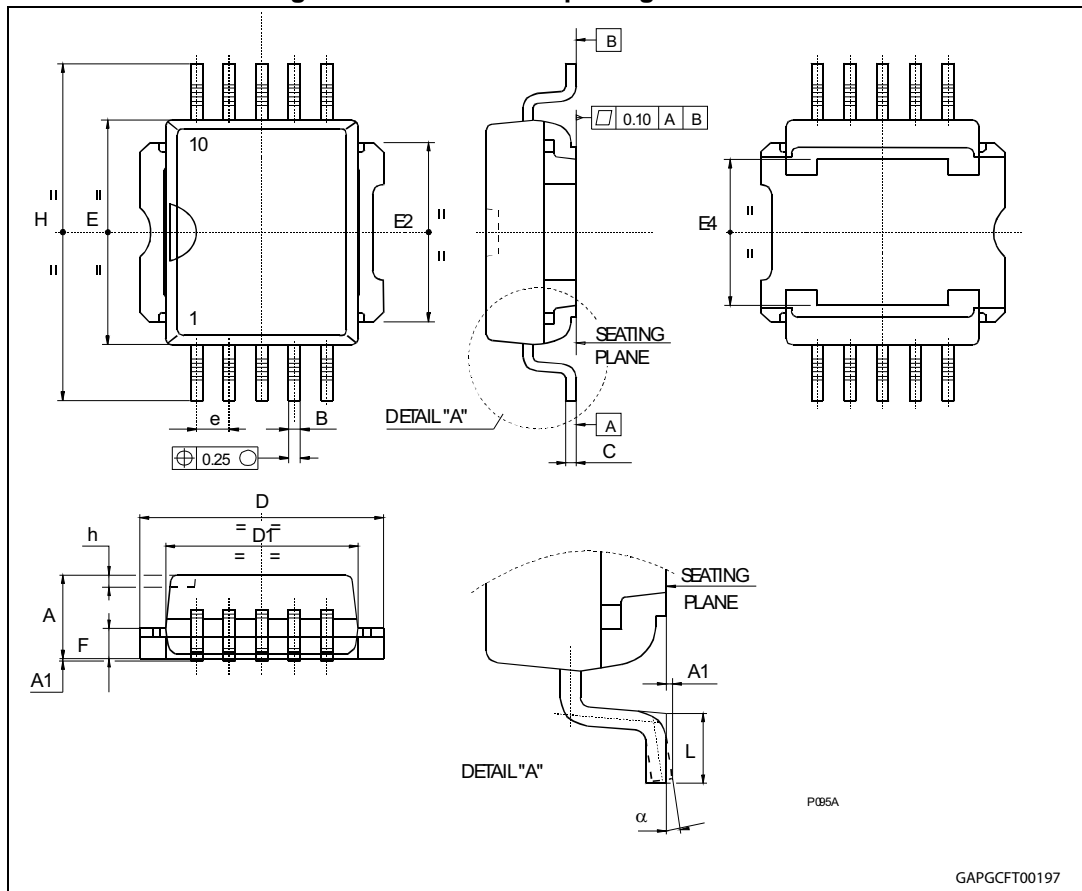

Table 16. PowerSO-10 mechanical data

Symbol	Millimeters		
	Min.	Typ.	Max.
A	3.35		3.65
A ⁽¹⁾	3.4		3.6
A1	0.00		0.10
B	0.40		0.60
B ⁽¹⁾	0.37		0.53
C	0.35		0.55
C ⁽¹⁾	0.23		0.32
D	9.40		9.60
D1	7.40		7.60
E	9.30		9.50
E2	7.20		7.60
E2 ⁽¹⁾	7.30		7.50
E4	5.90		6.10
E4 ⁽¹⁾	5.90		6.30
e		1.27	
F	1.25		1.35
F ⁽¹⁾	1.20		1.40
H	13.80		14.40
H ⁽¹⁾	13.85		14.35
h		0.50	
L	1.20		1.80
L ⁽¹⁾	0.80		1.10
a	0°		8°
α ⁽¹⁾	2°		8°

1. Muar only POA P013P.

5.3 Packing information

Figure 31. PowerSO-10 suggested pad layout and tube shipment (no suffix)

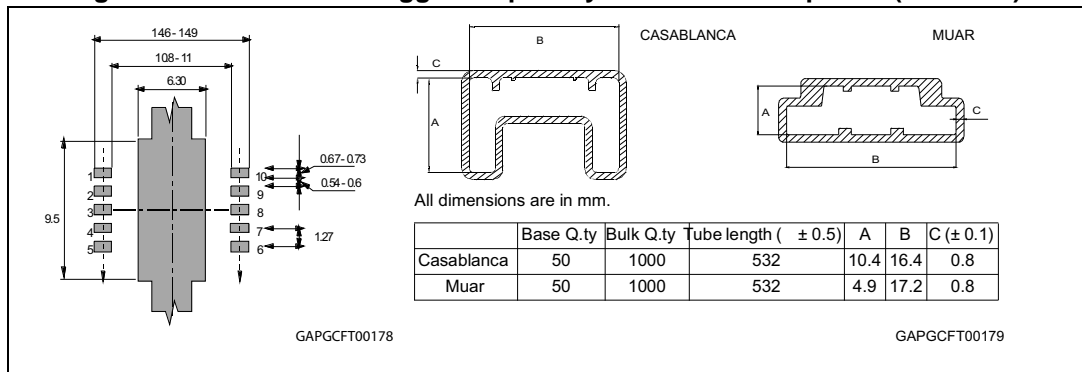
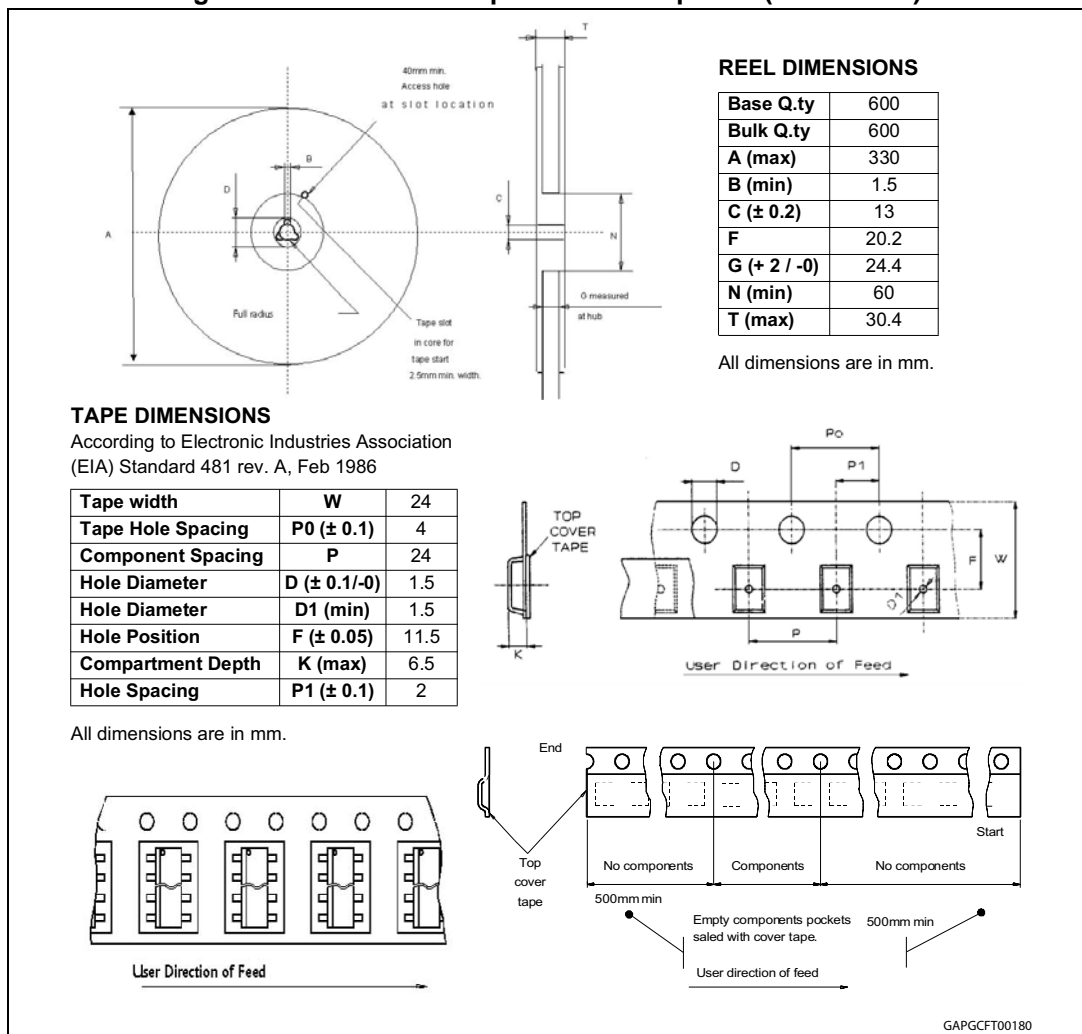

Figure 32. PowerSO-10 tape and reel shipment (suffix “TR”)



6 Order codes

Table 17. Device summary

Package	Order codes	
	Tube	Tape and reel
PowerSO-10	VN5T006ASP-E	VN5T006ASPTR-E

7 Revision history

Table 18. Document revision history

Date	Revision	Changes
19-Dec-2012	1	Initial release.
16-Jan-2013	2	Updated Figure 3: Current and voltage conventions Table 6: Switching ($V_{CC} = 24\text{ V}$; $T_j = 25^\circ\text{C}$) : – $dV_{OUT}/dt_{(on)}$: updated values Table 9: Current sense ($8\text{ V} < V_{CC} < 36\text{ V}$) : – I_{OL} : removed row – dK/K_{BULB2} : updated test conditions Updated Table 22: Turn-On voltage slope and Table 23: Turn-Off voltage slope
16-Jun-2013	3	Changed document status from “preliminary data” to “production data”
17-Sep-2013	4	Updated disclaimer.

Please Read Carefully:

Information in this document is provided solely in connection with ST products. STMicroelectronics NV and its subsidiaries ("ST") reserve the right to make changes, corrections, modifications or improvements, to this document, and the products and services described herein at any time, without notice.

All ST products are sold pursuant to ST's terms and conditions of sale.

Purchasers are solely responsible for the choice, selection and use of the ST products and services described herein, and ST assumes no liability whatsoever relating to the choice, selection or use of the ST products and services described herein.

No license, express or implied, by estoppel or otherwise, to any intellectual property rights is granted under this document. If any part of this document refers to any third party products or services it shall not be deemed a license grant by ST for the use of such third party products or services, or any intellectual property contained therein or considered as a warranty covering the use in any manner whatsoever of such third party products or services or any intellectual property contained therein.

UNLESS OTHERWISE SET FORTH IN ST'S TERMS AND CONDITIONS OF SALE ST DISCLAIMS ANY EXPRESS OR IMPLIED WARRANTY WITH RESPECT TO THE USE AND/OR SALE OF ST PRODUCTS INCLUDING WITHOUT LIMITATION IMPLIED WARRANTIES OF MERCHANTABILITY, FITNESS FOR A PARTICULAR PURPOSE (AND THEIR EQUIVALENTS UNDER THE LAWS OF ANY JURISDICTION), OR INFRINGEMENT OF ANY PATENT, COPYRIGHT OR OTHER INTELLECTUAL PROPERTY RIGHT.

ST PRODUCTS ARE NOT DESIGNED OR AUTHORIZED FOR USE IN: (A) SAFETY CRITICAL APPLICATIONS SUCH AS LIFE SUPPORTING, ACTIVE IMPLANTED DEVICES OR SYSTEMS WITH PRODUCT FUNCTIONAL SAFETY REQUIREMENTS; (B) AERONAUTIC APPLICATIONS; (C) AUTOMOTIVE APPLICATIONS OR ENVIRONMENTS, AND/OR (D) AEROSPACE APPLICATIONS OR ENVIRONMENTS. WHERE ST PRODUCTS ARE NOT DESIGNED FOR SUCH USE, THE PURCHASER SHALL USE PRODUCTS AT PURCHASER'S SOLE RISK, EVEN IF ST HAS BEEN INFORMED IN WRITING OF SUCH USAGE, UNLESS A PRODUCT IS EXPRESSLY DESIGNATED BY ST AS BEING INTENDED FOR "AUTOMOTIVE, AUTOMOTIVE SAFETY OR MEDICAL" INDUSTRY DOMAINS ACCORDING TO ST PRODUCT DESIGN SPECIFICATIONS. PRODUCTS FORMALLY ESCC, QML OR JAN QUALIFIED ARE DEEMED SUITABLE FOR USE IN AEROSPACE BY THE CORRESPONDING GOVERNMENTAL AGENCY.

Resale of ST products with provisions different from the statements and/or technical features set forth in this document shall immediately void any warranty granted by ST for the ST product or service described herein and shall not create or extend in any manner whatsoever, any liability of ST.

ST and the ST logo are trademarks or registered trademarks of ST in various countries.

Information in this document supersedes and replaces all information previously supplied.

The ST logo is a registered trademark of STMicroelectronics. All other names are the property of their respective owners.

© 2013 STMicroelectronics - All rights reserved

STMicroelectronics group of companies

Australia - Belgium - Brazil - Canada - China - Czech Republic - Finland - France - Germany - Hong Kong - India - Israel - Italy - Japan - Malaysia - Malta - Morocco - Philippines - Singapore - Spain - Sweden - Switzerland - United Kingdom - United States of America

www.st.com

