

LOW VOLTAGE CMOS DUAL D-TYPE FLIP FLOP WITH PRESET AND CLEAR (5V TOLERANT INPUTS)

- HIGH SPEED:
 $f_{MAX} = 145\text{MHz}$ (TYP.) at $V_{CC} = 3.3\text{V}$
- 5V TOLERANT INPUTS
- INPUT VOLTAGE LEVEL:
 $V_{IL} = 0.8\text{V}$, $V_{IH} = 2\text{V}$ AT $V_{CC} = 3\text{V}$
- LOW POWER DISSIPATION:
 $I_{CC} = 2\ \mu\text{A}$ (MAX.) at $T_A = 25^\circ\text{C}$
- LOW NOISE:
 $V_{OLP} = 0.3\text{V}$ (TYP.) at $V_{CC} = 3.3\text{V}$
- SYMMETRICAL OUTPUT IMPEDANCE:
 $|I_{OH}| = I_{OL} = 4\text{mA}$ (MIN)
- BALANCED PROPAGATION DELAYS:
 $t_{PLH} \cong t_{PHL}$
- OPERATING VOLTAGE RANGE:
 $V_{CC}(\text{OPR}) = 2\text{V}$ to 3.6V (1.2V Data Retention)
- PIN AND FUNCTION COMPATIBLE WITH 74 SERIES 74
- IMPROVED LATCH-UP IMMUNITY
- POWER DOWN PROTECTION ON INPUTS

DESCRIPTION

The 74LVX74 is a low voltage CMOS DUAL D-TYPE FLIP-FLOP WITH PRESET AND CLEAR NON INVERTING fabricated with sub-micron silicon gate and double-layer metal wiring C²MOS technology. It is ideal for low power, battery operated and low noise 3.3V applications.

Figure 1: Pin Connection And IEC Logic Symbols

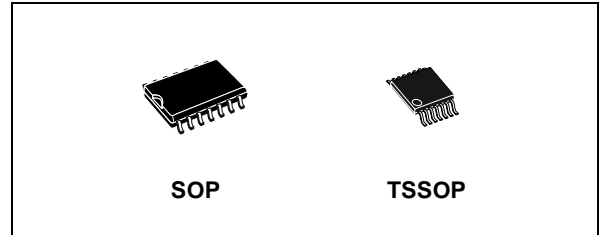
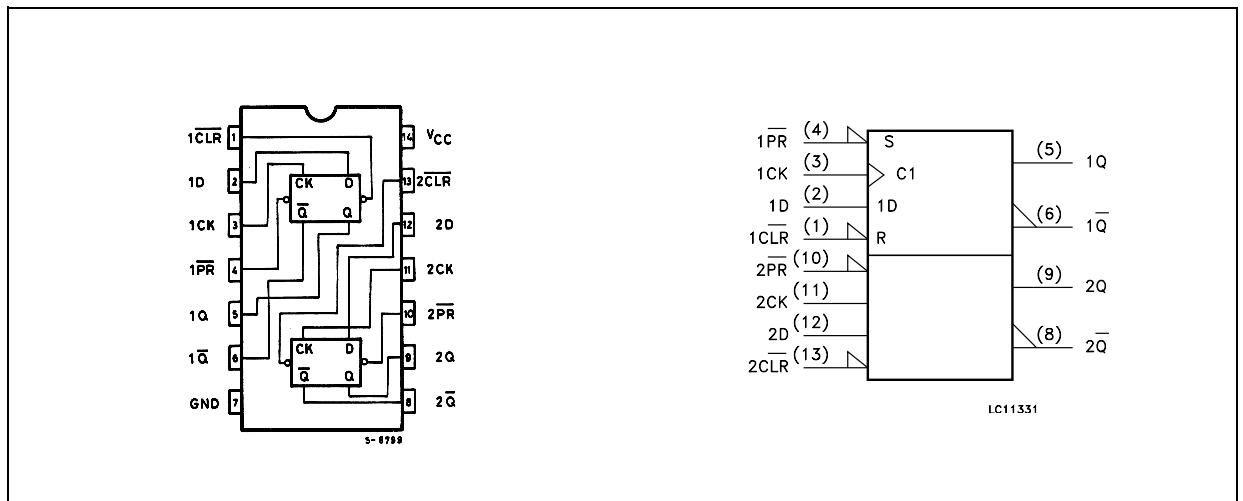

Table 1: Order Codes

PACKAGE	T & R
SOP	74LVX74MTR
TSSOP	74LVX74TTR

A signal on the D INPUT is transferred to the Q OUTPUT during the positive going transition of the clock pulse. CLR and PR are independent of the clock and accomplished by a low setting on the appropriate input.

Power down protection is provided on all inputs and 0 to 7V can be accepted on inputs with no regard to the supply voltage.

This device can be used to interface 5V to 3V system. It combines high speed performance with the true CMOS low power consumption. All inputs and outputs are equipped with protection circuits against static discharge, giving them 2KV ESD immunity and transient excess voltage.

Figure 2: Input Equivalent Circuit

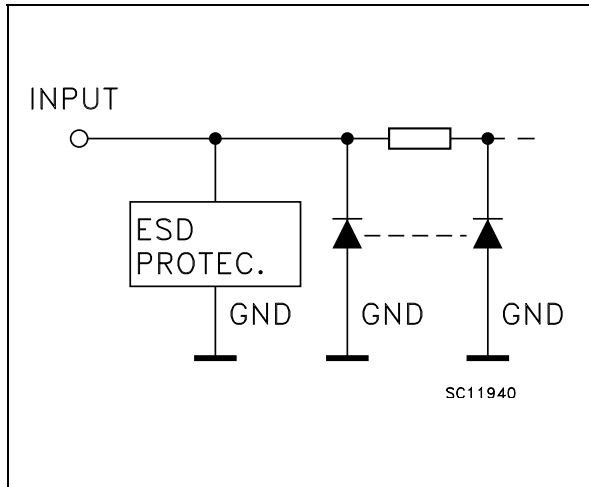

Table 2: Pin Description

PIN N°	SYMBOL	NAME AND FUNCTION
1, 13	$\overline{1CLR}, \overline{2CLR}$	Asynchronous Reset - Direct Input
2, 12	1D, 2D	Data Inputs
3, 11	1CK, 2CK	Clock Input (LOW to HIGH, Edge Triggered)
4, 10	1PR, 2PR	Asynchronous Set - Direct Input
5, 9	1Q, 2Q	True Flip-Flop Outputs
6, 8	1 \overline{Q} , 2 \overline{Q}	Complement Flip-Flop Outputs
7	GND	Ground (0V)
14	V _{CC}	Positive Supply Voltage

Table 3: Truth Table

INPUTS				OUTPUTS		FUNCTION
\overline{CLR}	\overline{PR}	D	CK	Q	\overline{Q}	
L	H	X	X	L	H	CLEAR
H	L	X	X	H	L	PRESET
L	L	X	X	H	H	
H	H	L		L	H	
H	H	H		H	L	
H	H	X		Q _n	\overline{Q}_n	NO CHANGE

X : Don't Care

Figure 3: Logic Diagram

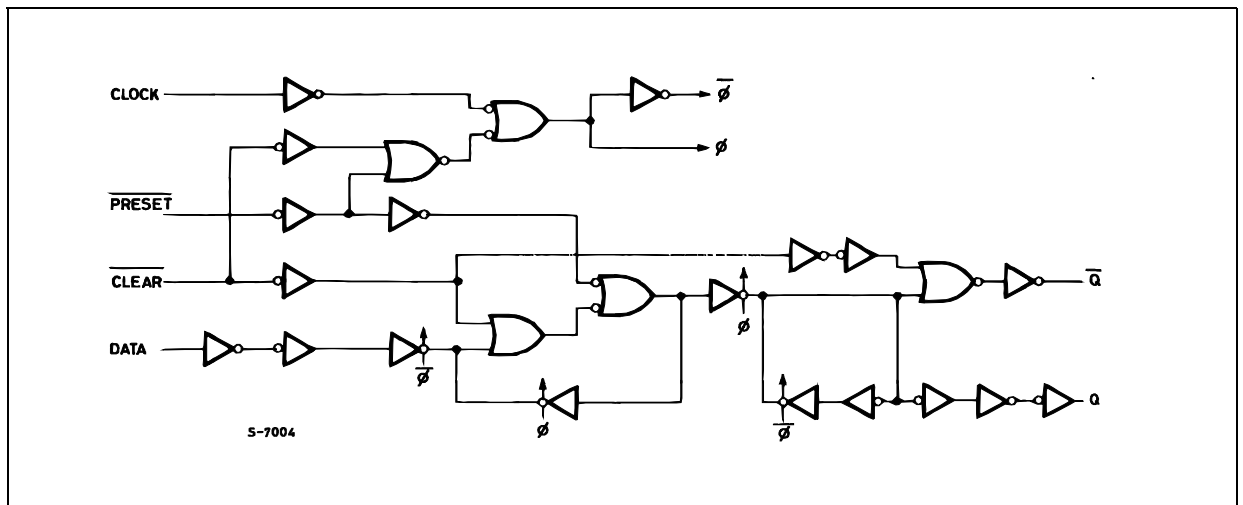

This logic diagram has not been used to estimate propagation delays

Table 4: Absolute Maximum Ratings

Symbol	Parameter	Value	Unit
V_{CC}	Supply Voltage	-0.5 to +7.0	V
V_I	DC Input Voltage	-0.5 to +7.0	V
V_O	DC Output Voltage	-0.5 to $V_{CC} + 0.5$	V
I_{IK}	DC Input Diode Current	- 20	mA
I_{OK}	DC Output Diode Current	± 20	mA
I_O	DC Output Current	± 25	mA
I_{CC} or I_{GND}	DC V_{CC} or Ground Current	± 50	mA
T_{stg}	Storage Temperature	-65 to +150	°C
T_L	Lead Temperature (10 sec)	300	°C

Absolute Maximum Ratings are those values beyond which damage to the device may occur. Functional operation under these conditions is not implied.

Table 5: Recommended Operating Conditions

Symbol	Parameter	Value	Unit
V_{CC}	Supply Voltage (note 1)	2 to 3.6	V
V_I	Input Voltage	0 to 5.5	V
V_O	Output Voltage	0 to V_{CC}	V
T_{op}	Operating Temperature	-55 to 125	°C
dt/dv	Input Rise and Fall Time (note 2) ($V_{CC} = 3.3V$)	0 to 100	ns/V

1) Truth Table guaranteed: 1.2V to 3.6V

2) V_{IN} from 0.8V to 2.0V

Table 6: DC Specifications

Symbol	Parameter	Test Condition		Value						Unit	
				$T_A = 25^\circ\text{C}$			-40 to 85°C		-55 to 125°C		
				Min.	Typ.	Max.	Min.	Max.	Min.		Max.
V_{IH}	High Level Input Voltage	V_{CC} (V)		1.5			1.5		1.5		V
				2.0			2.0		2.0		
				2.4			2.4		2.4		
V_{IL}	Low Level Input Voltage	V_{CC} (V)				0.5		0.5		0.5	V
						0.8		0.8		0.8	
						0.8		0.8		0.8	
V_{OH}	High Level Output Voltage	V_{CC} (V)	$I_O = -50 \mu\text{A}$	1.9	2.0		1.9		1.9		V
			$I_O = -50 \mu\text{A}$	2.9	3.0		2.9		2.9		
			$I_O = -4 \text{ mA}$	2.58			2.48		2.4		
V_{OL}	Low Level Output Voltage	V_{CC} (V)	$I_O = 50 \mu\text{A}$		0.0	0.1		0.1		0.1	V
			$I_O = 50 \mu\text{A}$		0.0	0.1		0.1		0.1	
			$I_O = 4 \text{ mA}$			0.36		0.44		0.55	
I_I	Input Leakage Current	3.6	$V_I = 5V$ or GND			± 0.1		± 1		± 1	μA
I_{CC}	Quiescent Supply Current	3.6	$V_I = V_{CC}$ or GND			2		20		20	μA

Table 7: Dynamic Switching Characteristics

Symbol	Parameter	Test Condition		Value						Unit	
		V _{CC} (V)	C _L (pF)	T _A = 25°C			-40 to 85°C		-55 to 125°C		
				Min.	Typ.	Max.	Min.	Max.	Min.		Max.
V _{OLP}	Dynamic Low Voltage Quiet Output (note 1, 2)	3.3	C _L = 50 pF		0.3	0.5					V
V _{OLV}				-0.5	-0.3						
V _{IHD}	Dynamic High Voltage Input (note 1, 3)	3.3		2							
V _{ILD}	Dynamic Low Voltage Input (note 1, 3)	3.3				0.8					

1) Worst case package.

2) Max number of outputs defined as (n). Data inputs are driven 0V to 3.3V, (n-1) outputs switching and one output at GND.

3) Max number of data inputs (n) switching. (n-1) switching 0V to 3.3V. Inputs under test switching: 3.3V to threshold (V_{ILD}), 0V to threshold (V_{IHD}), f=1MHz.

Table 8: AC Electrical Characteristics (Input t_r = t_f = 3ns)

Symbol	Parameter	Test Condition		Value						Unit	
		V _{CC} (V)	C _L (pF)	T _A = 25°C			-40 to 85°C		-55 to 125°C		
				Min.	Typ.	Max.	Min.	Max.	Min.		Max.
t _{PLH} t _{PHL}	Propagation Delay Time CK to Q or Q	2.7	15		7.3	15.0	1.0	18.5	1.0	18.5	ns
		2.7	50		9.8	18.5	1.0	22.0	1.0	22.0	
		3.3 ^(*)	15		5.7	9.7	1.0	11.5	1.0	11.5	
		3.3 ^(*)	50		8.2	13.2	1.0	15.0	1.0	15.0	
t _{PLH} t _{PHL}	Propagation Delay Time PR or CLR to Q or Q	2.7	15		8.4	15.6	1.0	18.5	1.0	18.5	ns
		2.7	50		10.9	19.1	1.0	22.0	1.0	22.0	
		3.3 ^(*)	15		6.6	10.1	1.0	12.0	1.0	12.0	
		3.3 ^(*)	50		9.1	13.6	1.0	15.5	1.0	15.5	
t _w	Minimum Pulse Width HIGH or LOW, CK	2.7	50			8.5		10.0		10.0	ns
		3.3 ^(*)	50			6.0		7.0		7.0	
t _{w(L)}	Minimum Pulse Width LOW PR or CLR	2.7	50			8.5		10.0		10.0	ns
		3.3 ^(*)	50			6.0		7.0		7.0	
t _s	Minimum Setup Time D to CK HIGH or LOW	2.7	50			8.0		9.5		9.5	ns
		3.3 ^(*)	50			5.5		6.5		6.5	
t _h	Minimum Hold Time D to CK HIGH or LOW	2.7	50			0.5		0.5		0.5	ns
		3.3 ^(*)	50			0.5		0.5		0.5	
t _{REM}	Minimum Removal Time PR or CLR to CK	2.7	50			6.5		7.5		7.5	ns
		3.3 ^(*)	50			5.0		5.0		5.0	
f _{MAX}	Maximum Clock Frequency	2.7	15		55	135		50		50	MHz
		2.7	50		45	60		40		40	
		3.3 ^(*)	15		95	145		80		80	
		3.3 ^(*)	50		60	85		50		50	
t _{OSLH} t _{OSHL}	Output To Output Skew Time (note 1, 2)	2.7	50		0.5	1.0		1.5		1.5	ns
		3.3 ^(*)	50		0.5	1.0		1.5		1.5	

1) Skew is defined as the absolute value of the difference between the actual propagation delay for any two outputs of the same device switching in the same direction, either HIGH or LOW

2) Parameter guaranteed by design

(*) Voltage range is 3.3V ± 0.3V

Table 9: Capacitive Characteristics

Symbol	Parameter	Test Condition		Value						Unit	
		V _{CC} (V)		T _A = 25°C			-40 to 85°C		-55 to 125°C		
				Min.	Typ.	Max.	Min.	Max.	Min.		Max.
C _{IN}	Input Capacitance	3.3			4	10		10		10	pF
C _{PD}	Power Dissipation Capacitance (note 1)	3.3	f _{IN} = 10 MHz		25						pF

1) C_{PD} is defined as the value of the IC's internal equivalent capacitance which is calculated from the operating current consumption without load. (Refer to Test Circuit). Average operating current can be obtained by the following equation. $I_{CC(opr)} = C_{PD} \times V_{CC} \times f_{IN} + I_{CC}/2$ (per circuit)

Figure 4: Test Circuit

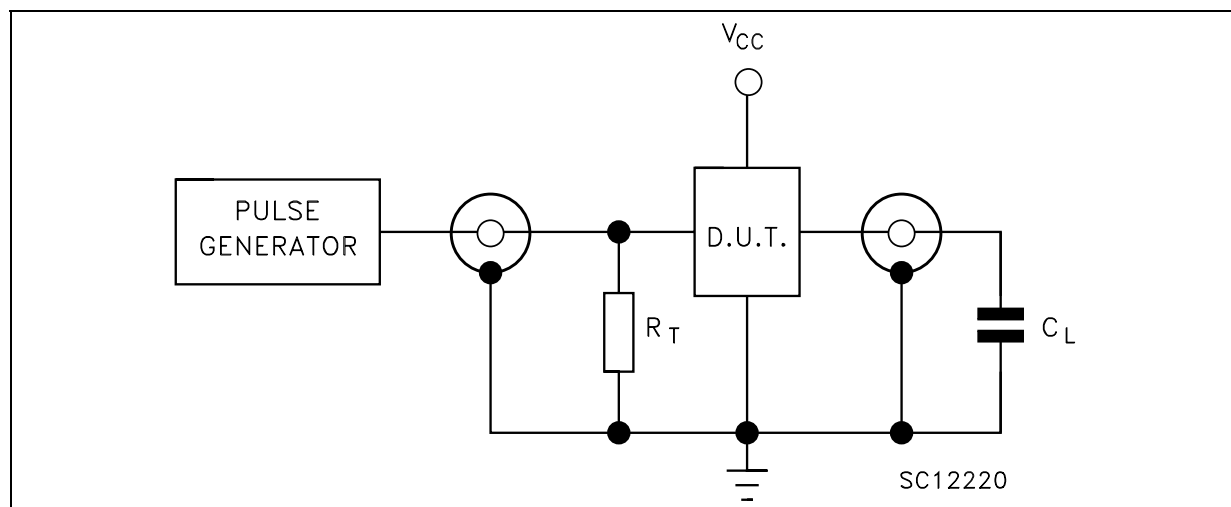

C_L = 15/50pF or equivalent (includes jig and probe capacitance)
R_T = Z_{OUT} of pulse generator (typically 50Ω)

Figure 5: Waveform - Propagation Delays, Setup And Hold Times (f=1MHz; 50% duty cycle)

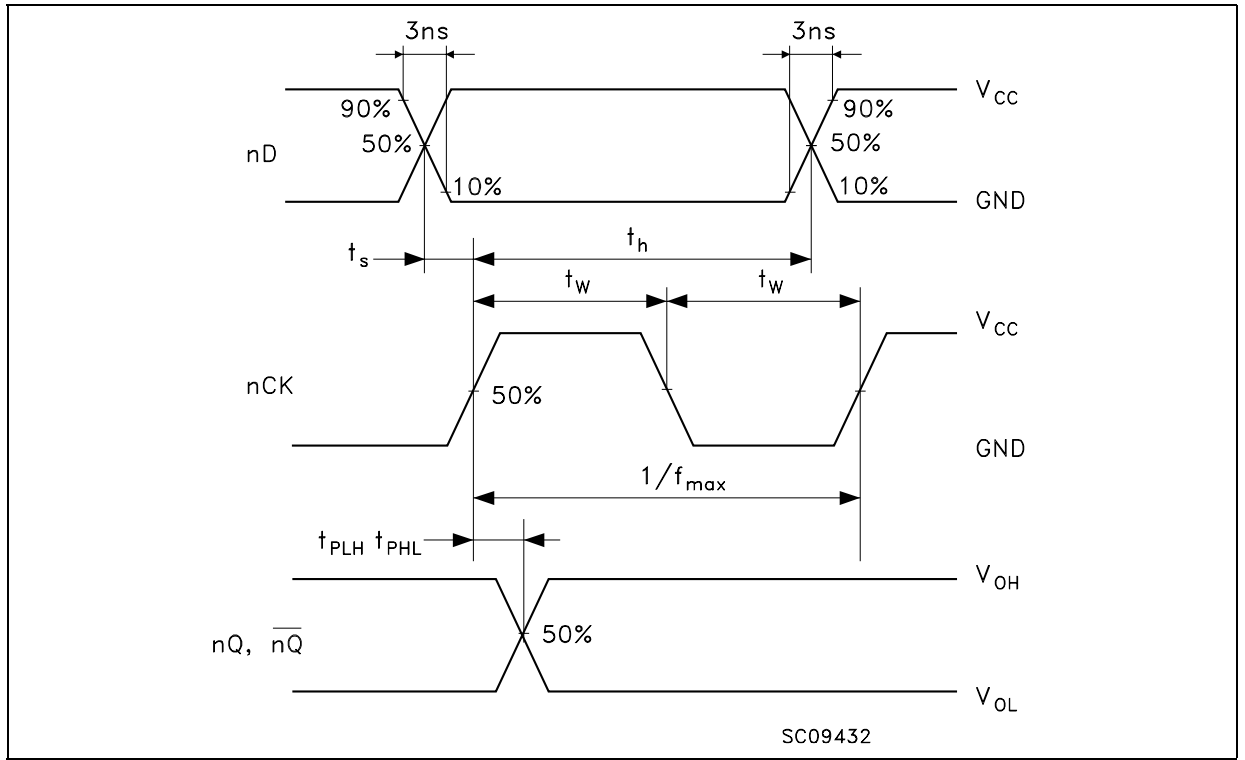

Figure 6: Waveform - Recovery Time (f=1MHz; 50% duty cycle)

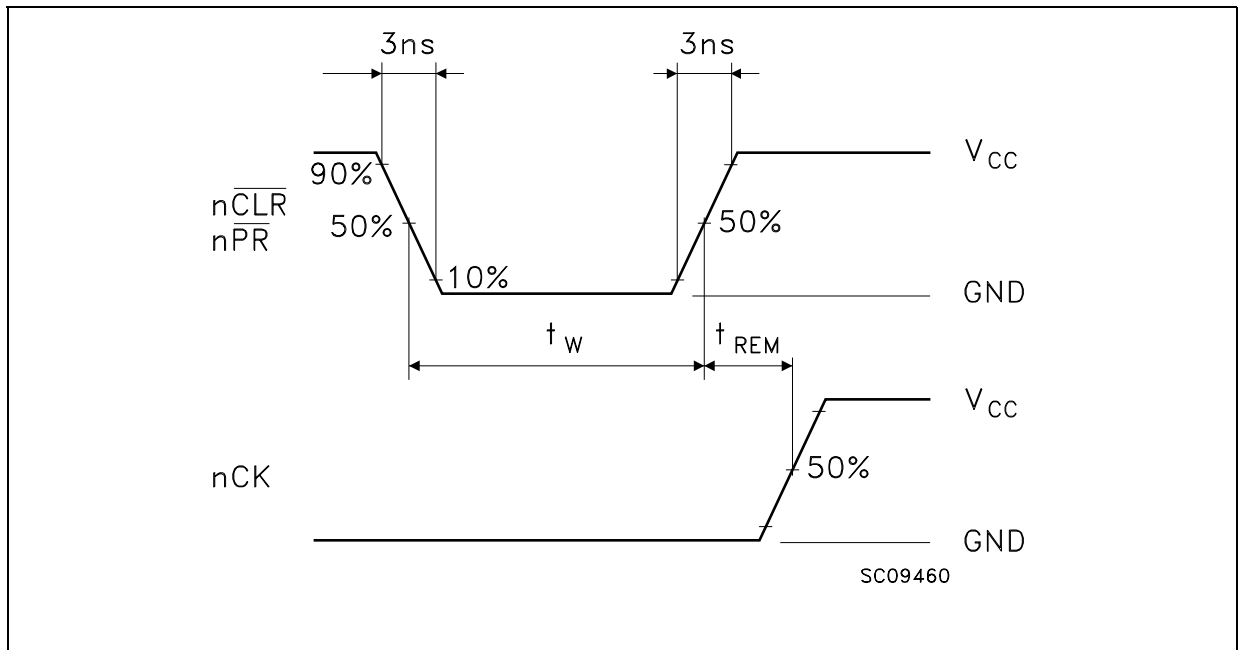

Figure 7: Waveform - Propagation Delays, Minimum Pulse Width ($f=1\text{MHz}$; 50% duty cycle)

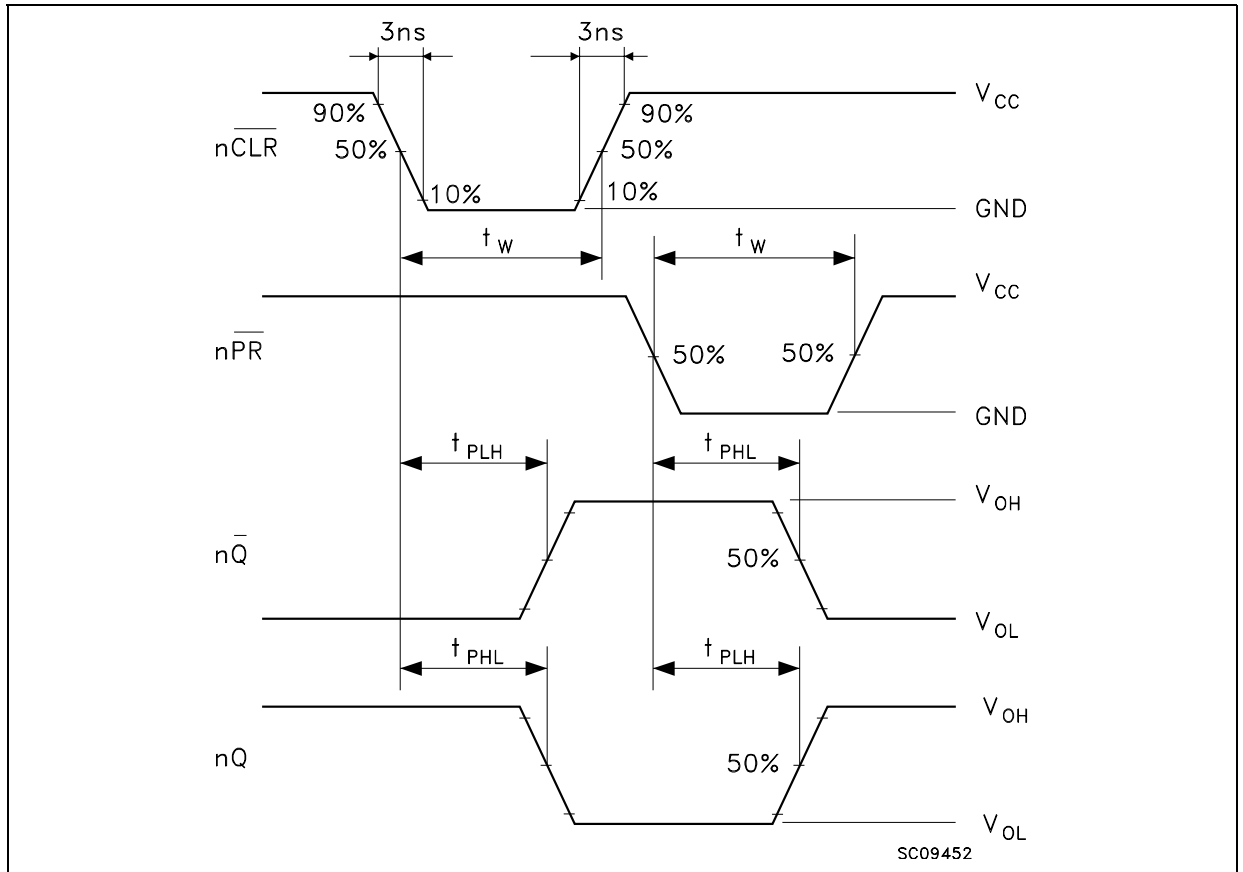
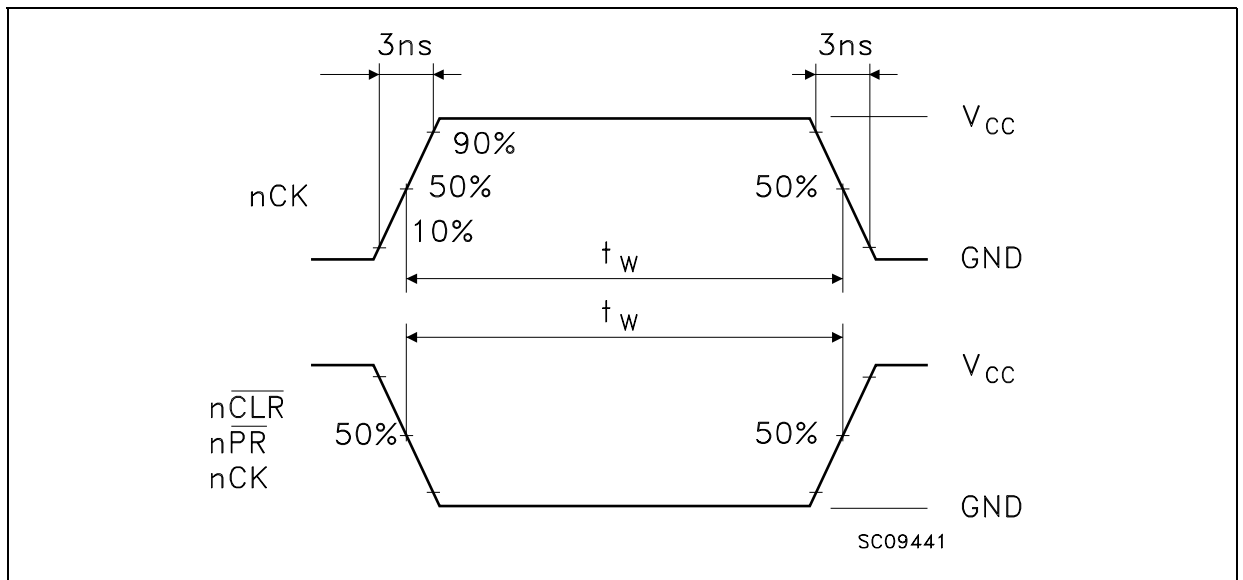
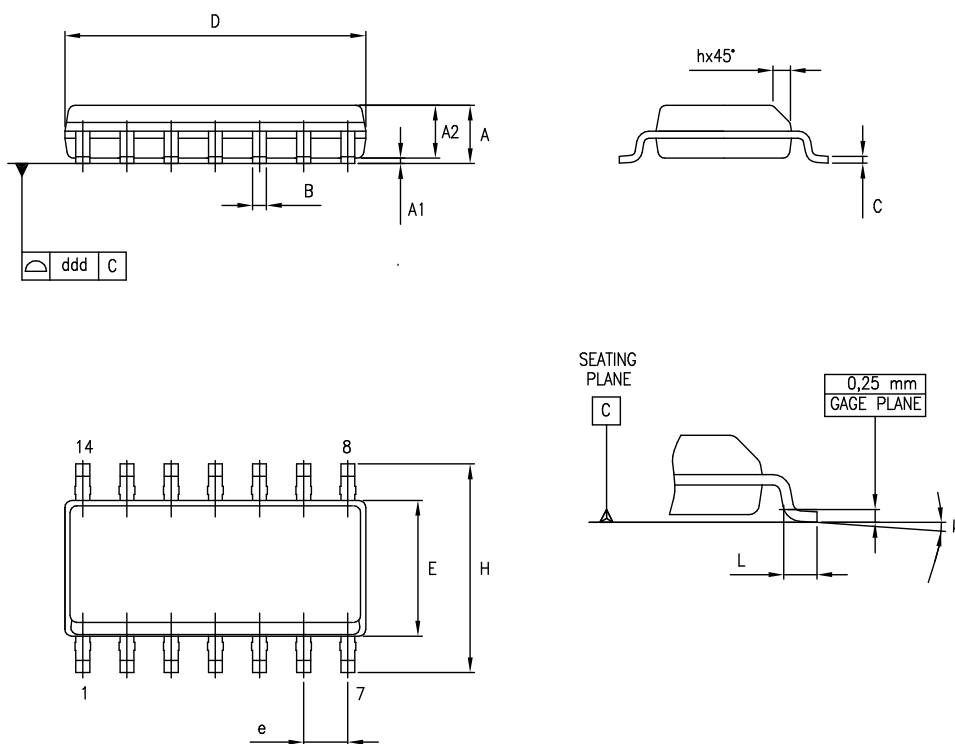

Figure 8: Waveform - Minimum Pulse Width



SO-14 MECHANICAL DATA

DIM.	mm.			inch		
	MIN.	TYP.	MAX.	MIN.	TYP.	MAX.
A	1.35		1.75	0.053		0.069
A1	0.1		0.25	0.004		0.010
A2	1.10		1.65	0.043		0.065
B	0.33		0.51	0.013		0.020
C	0.19		0.25	0.007		0.010
D	8.55		8.75	0.337		0.344
E	3.8		4.0	0.150		0.157
e		1.27			0.050	
H	5.8		6.2	0.228		0.244
h	0.25		0.50	0.010		0.020
L	0.4		1.27	0.016		0.050
k	0°		8°	0°		8°
ddd			0.100			0.004



0016019D

TSSOP14 MECHANICAL DATA

DIM.	mm.			inch		
	MIN.	TYP	MAX.	MIN.	TYP.	MAX.
A			1.2			0.047
A1	0.05		0.15	0.002	0.004	0.006
A2	0.8	1	1.05	0.031	0.039	0.041
b	0.19		0.30	0.007		0.012
c	0.09		0.20	0.004		0.0089
D	4.9	5	5.1	0.193	0.197	0.201
E	6.2	6.4	6.6	0.244	0.252	0.260
E1	4.3	4.4	4.48	0.169	0.173	0.176
e		0.65 BSC			0.0256 BSC	
K	0°		8°	0°		8°
L	0.45	0.60	0.75	0.018	0.024	0.030

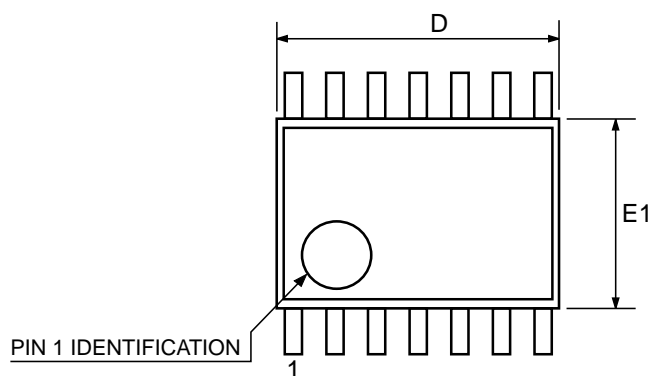
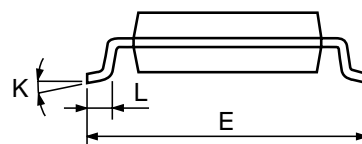
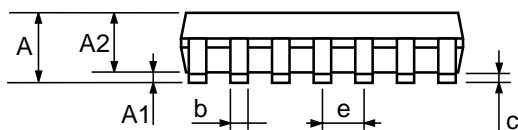

0080337D

Tape & Reel SO-14 MECHANICAL DATA

DIM.	mm.			inch		
	MIN.	TYP	MAX.	MIN.	TYP.	MAX.
A			330			12.992
C	12.8		13.2	0.504		0.519
D	20.2			0.795		
N	60			2.362		
T			22.4			0.882
Ao	6.4		6.6	0.252		0.260
Bo	9		9.2	0.354		0.362
Ko	2.1		2.3	0.082		0.090
Po	3.9		4.1	0.153		0.161
P	7.9		8.1	0.311		0.319

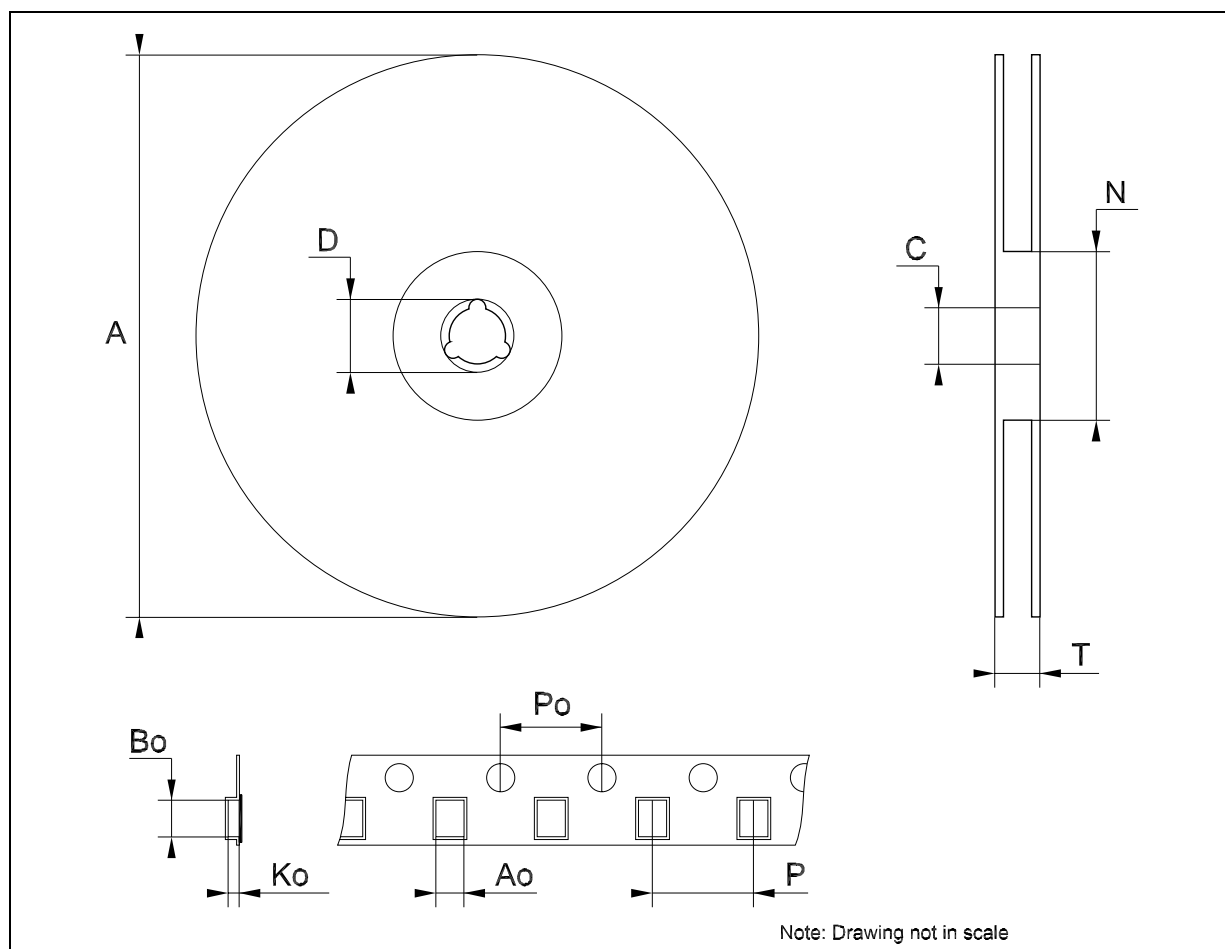

Tape & Reel TSSOP14 MECHANICAL DATA

DIM.	mm.			inch		
	MIN.	TYP	MAX.	MIN.	TYP.	MAX.
A			330			12.992
C	12.8		13.2	0.504		0.519
D	20.2			0.795		
N	60			2.362		
T			22.4			0.882
Ao	6.7		6.9	0.264		0.272
Bo	5.3		5.5	0.209		0.217
Ko	1.6		1.8	0.063		0.071
Po	3.9		4.1	0.153		0.161
P	7.9		8.1	0.311		0.319



Table 10: Revision History

Date	Revision	Description of Changes
27-Aug-2004	3	Ordering Codes Revision - pag. 1.

Information furnished is believed to be accurate and reliable. However, STMicroelectronics assumes no responsibility for the consequences of use of such information nor for any infringement of patents or other rights of third parties which may result from its use. No license is granted by implication or otherwise under any patent or patent rights of STMicroelectronics. Specifications mentioned in this publication are subject to change without notice. This publication supersedes and replaces all information previously supplied. STMicroelectronics products are not authorized for use as critical components in life support devices or systems without express written approval of STMicroelectronics.

The ST logo is a registered trademark of STMicroelectronics

All other names are the property of their respective owners

© 2004 STMicroelectronics - All Rights Reserved

STMicroelectronics group of companies

Australia - Belgium - Brazil - Canada - China - Czech Republic - Finland - France - Germany - Hong Kong - India - Israel - Italy - Japan - Malaysia - Malta - Morocco - Singapore - Spain - Sweden - Switzerland - United Kingdom - United States of America

www.st.com