

Introduction

The objective of this document is to briefly explain the IEC 61000-4-5 standards and to show the benefits of having a range of protection devices specified according to this standard. For further details on IEC 61000-4-5 refer to the International Electrotechnical Commission web site.

Industrial and consumer equipment are subjected to various surges. Here are the main ones:

- IEC 61000-4-2: ESD surges affect most of consumer equipment. The more stressful ESD standard is IEC 61000-4-2 (few tens of ns duration) but other standards such as human body model (HBM), machine model (MM) exist.
- IEC 61000-4-4: This standard is made to check the capability of the equipment to survive repetitive electrical fast transients and bursts.
- IEC 61000-4-5: Lightning and industrial surges modeled by IEC 61000-4-5. This is the one we will describe in this document.
- Telecommunication lines are exposed to lightning either directly on the equipment or due to induced effect because of ground potential change.

In addition to these surges, a telecommunication line may also be disturbed by either power induction or power contact with main AC lines. Depending on the country, these surges have been mainly modeled in:

- Telcordia GR-1089 core for America with 2/10 μ s and 10/1000 μ s surges
- ITU-T K series for the rest of the world with 10/700 μ s surges

1 IEC 61000-4-5

Power lines are subjected to switching and lightning transients.

1.1 Power system switching transients

Power system switching transients can be separated into transients associated with:

- Major power system switching disturbances, such as capacitor bank switching
- Minor local switching activity or load changes in the power distribution system
- Resonating circuits associated with switching devices, such as thyristors
- Various system faults, such as short circuits and arcing faults to the grounding system of the installation

1.2 Lightning transients

The major mechanisms by which lightning produces surge voltages are the following:

- Direct lightning strokes to outdoor circuits injecting high currents and producing over voltages.
- Indirect lightning strikes (i.e. strikes between or within clouds or to nearby objects which produce electromagnetic fields) that induce voltages/currents on the conductors outside and/or inside a building.
- Lightning ground current flows resulting from nearby direct-to-earth discharges coupling into the common ground paths of the grounding system of the installation. The rapid change of voltages and flows of current which can occur as a result of the operation of a lightning protection device can induce electromagnetic disturbances into adjacent equipment.
- Target of the IEC 61000-4-5 is to provide a model to simulate these surges and then to be able to check if the equipment is able to survive them.

2 IEC 61000-4-5 definition

2.1 Classes and voltage levels

The standard specifies different classes depending on where the equipment is installed. For each class a corresponding peak voltage is applicable (see [Table 1](#)).

Table 1. Classes and voltage levels

Class	Environment	Voltage level
0	Well protected environment, often in a special room	25 V
1	Partially protected environment	500 V
2	Electrical environment where the cables are well separated, even at short runs	1 kV
3	Electrical environment where power and signal cables run in parallel	2 kV
4	Electrical environment where the interconnections include outdoor cables along with the power cable, and cables are used for both electronics and electric circuits	4 kV
5	Electrical environment for electronic equipment connected to telecommunication cables and overhead power lines in a non-densely populated area	Test level 4

Starting at a 500 V surge, it is generally required to protect the equipment with a specific device.

2.2 Surge generator

The generator used to model the surge is described in [Figure 1](#).

Figure 1. IEC 61000-4-5 surge generator

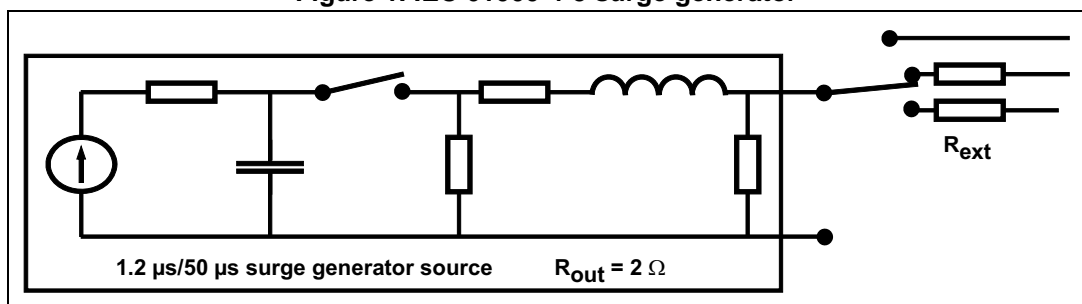

In open mode, the generator delivers a 1.2 μ s/50 μ s voltage waveform, and in short circuit, the current waveform is 8/20 μ s. This kind of generator is called a combination wave generator. The surge is shown on [Figure 2](#) and [Figure 3](#).

Figure 2. Voltage waveform in open circuit

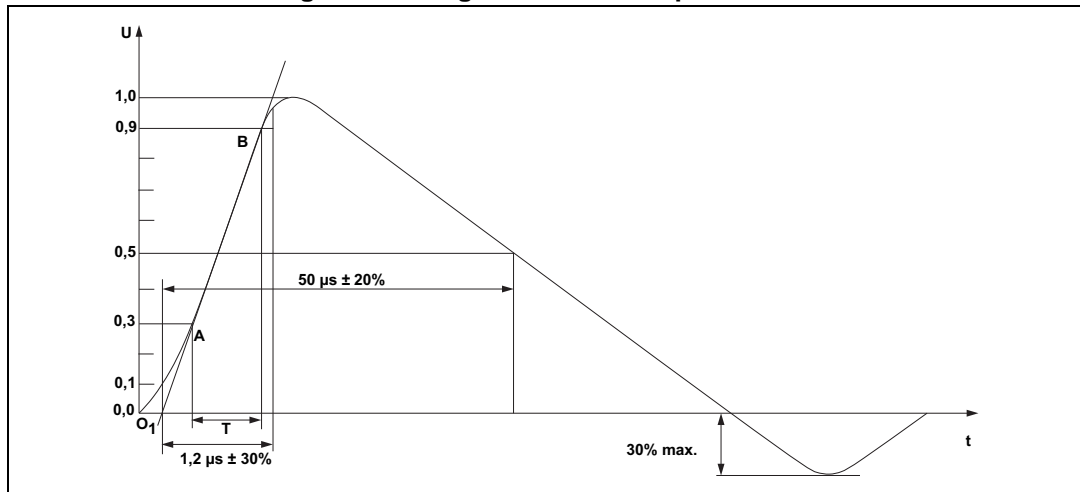
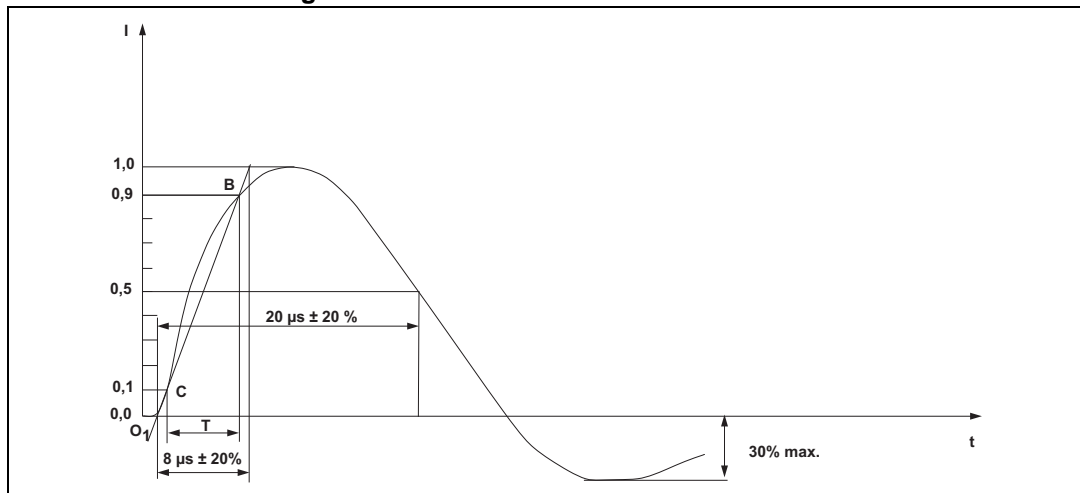

Figure 3. Current waveform in short circuit



For the same environment, there is a distinction between power lines and data lines, and an additional serial resistance (R_{ext}) may be required between the DUT (device under test) and the surge generator.

The selection of the source impedance ($R_{out} + R_{ext}$) depends on the kind of equipment to be protected:

- The 2 Ω impedance represents the source impedance of the low-voltage power supply network. The generator is used alone with its effective output impedance of 2 Ω . The surge is applied in a differential mode.
- The 12 Ω (10 Ω + 2 Ω) impedance represents the source impedance of the low-voltage power supply network and ground (common mode). A generator with an additional resistor of 10 Ω in series is used.
- The effective 42 Ω (40 Ω + 2 Ω) impedance represents the source impedance between all other lines and ground. A generator with an additional resistance of 40 Ω in series is used.

As protection devices are sized with the surge current, [Table 2](#) shows the maximum peak current values depending on voltage level and R_{ext} when surge generator is short circuited.

Table 2. Maximum peak current values depending on voltage level and R_{ext}

	Class 0	Class 1	Class 2	Class 3	Class 4
	25 V	500 V	1 kV	2 kV	4 kV
$R_{eq} = 42 \Omega$	0.6 A	12 A	24 A	48 A	96 A
$R_{eq} = 12 \Omega$	2.1 A	42 A	84 A	167 A	334 A
$R_{eq} = 2 \Omega$	12.5 A	250 A	500 A	1000 A	2000 A

Test schematics are shown in [Figure 4](#) and [Figure 5](#).

Figure 4. Differential mode test set-up

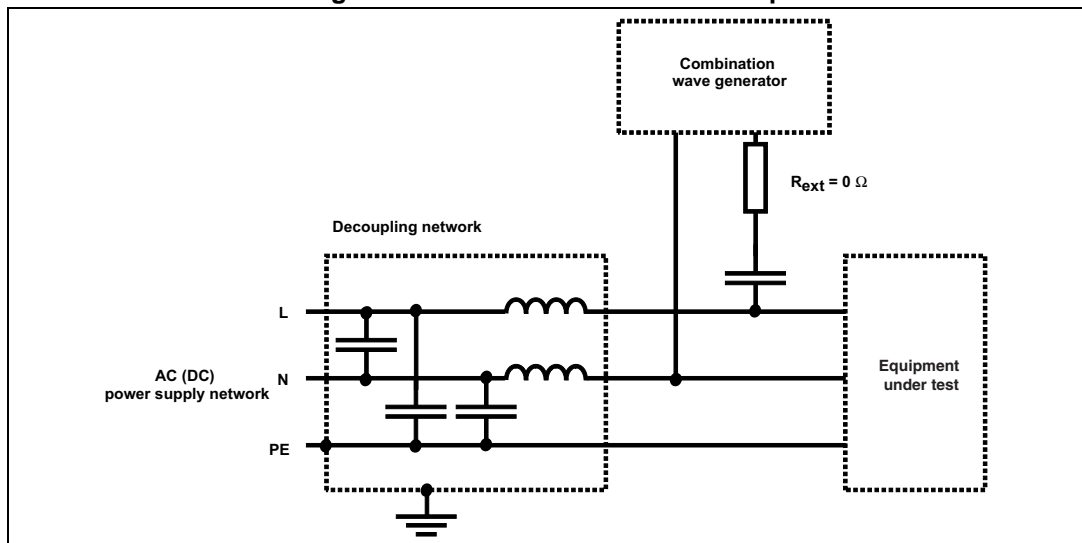

Figure 5. Common mode test set-up

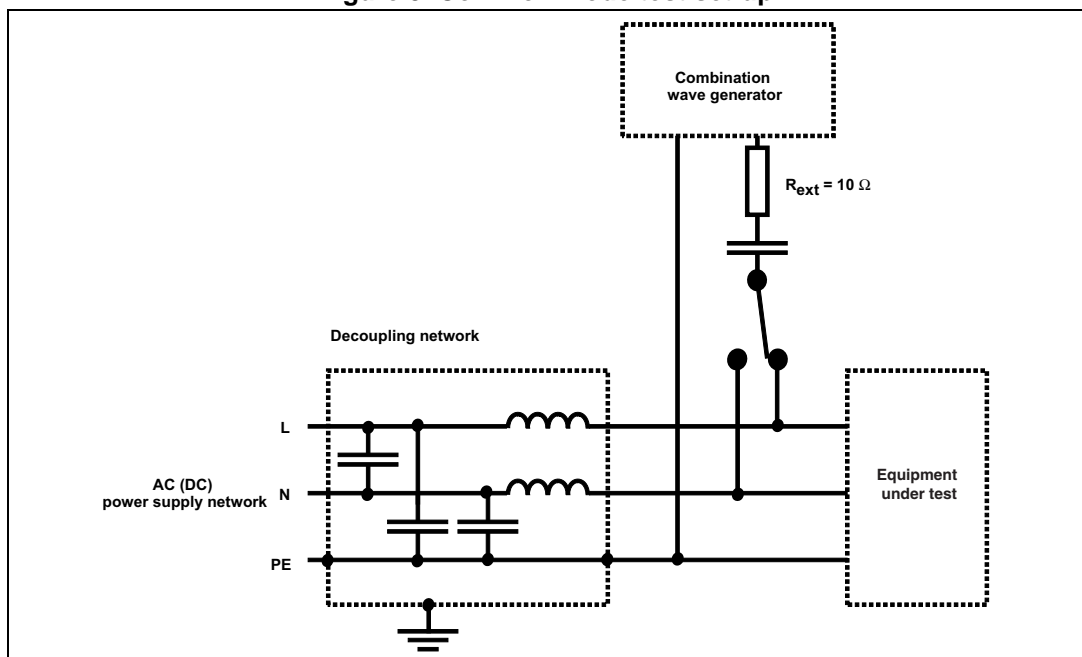
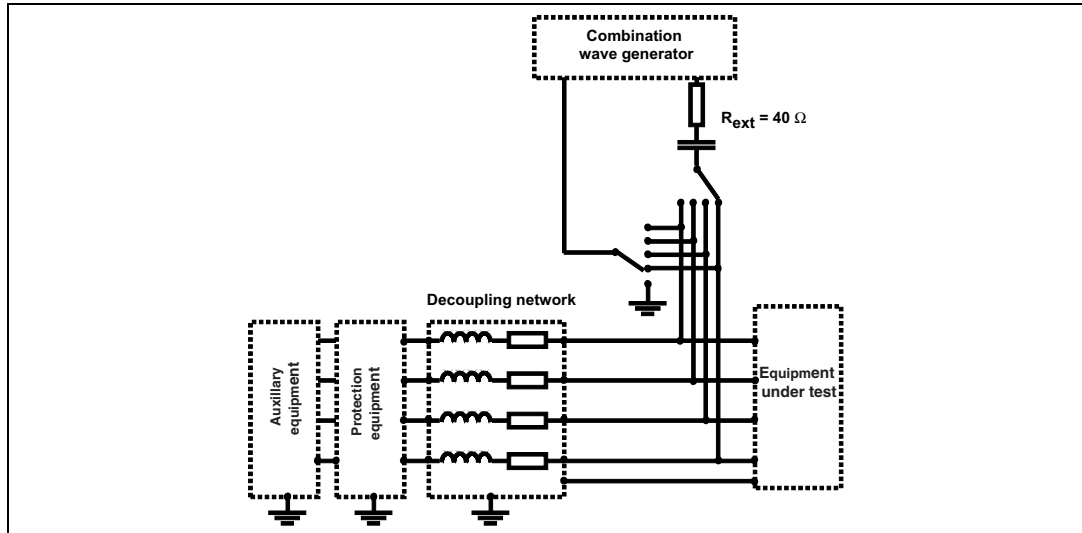

Figure 4 and Figure 5 show the test schematics when the equipment is connected to power lines.

For other types of lines, the decoupling network is slightly different on both line-to-line and line-to-ground tests. Furthermore the test must be done with $R_{ext} = 40 \Omega$ (see Figure 6).

Figure 6. IEC 61000-4-5 multi-line test set-up



In practice, this surge is applied to equipment and not to a specific protection device.

If the protection device is directly located at the input of the equipment, the protection device has to withstand the complete surge. In some cases, the protection device is not located at the input but somewhere in the middle of a board and then the protection device sees a slightly different surge.

3 Protection devices

The device used to protect against IEC 61000-4-5 is generally a clamping device located in parallel with the circuit to be protected. This protection device limits the voltage to a specified value V_{CL} (Clamping voltage) by absorbing the surge current. Its surge current capability is specified in its datasheet: I_{PP} (peak pulse current).

Figure 7 gives the I/V characteristics of a clamping device.

Figure 7. I/V characteristics of a unidirectional clamping devices

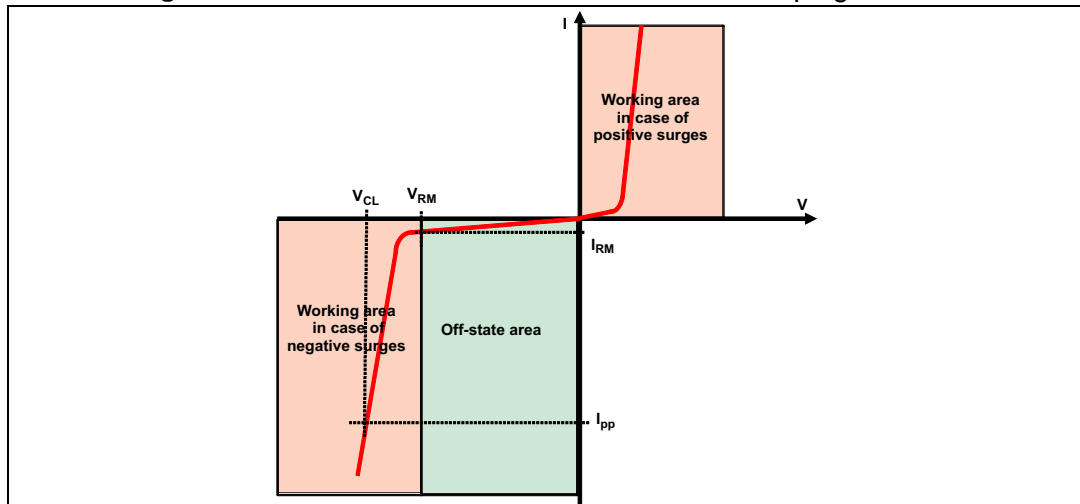

The goal of a protection device is to survive the surge (I_{PP}), and to protect the equipment by limiting the surge voltage (V_{CL}) below the maximum admissible voltage of the equipment/circuit.

I_{PP} protection

The I_{PP} of the protection must be defined according to the surge. In order to withstand a surge, a protection device should have an I_{PP} (8/20 μ s surge) higher than the peak current generated by the standard. It is worthless to choose a protection defined by a 10/1000 μ s surge (this surge is dedicated to telecommunication lines) when the standard requires to comply with 8/20 μ s.

ST has been specifying its protection devices with 10/1000 μ s and 8/20 μ s surges for years. Trends toward optimized protection in cost and in size leads us to produce dedicated protection devices specified according to IEC 61000-4-5.

V_{CL} protection

To protect a circuit from a surge, the protection device should have a V_{CL} (8/20 μ s surge) lower than the maximum voltage the circuit can withstand.

Using a unidirectional device is safer as clamping voltage will be limited to V_{CL} in one direction and to a forward voltage on the other direction.

Bidirectional device must be used only if the application requires to accept a reverse plug-in (on DC power lines) or if located on AC lines.

4 PEP01-5841 as an example

This device is dedicated to the protection of power supplies of PoE in PSE side. Typically PoE power supply is 0 to -48 V. This protection device embeds 4 cells to protect against IEC 61000-4-5 1 kV under 42 Ω which leads to a 24 A surge current. Topology is given on [Figure 8](#).

Figure 8. PEP01-5841 functional diagram

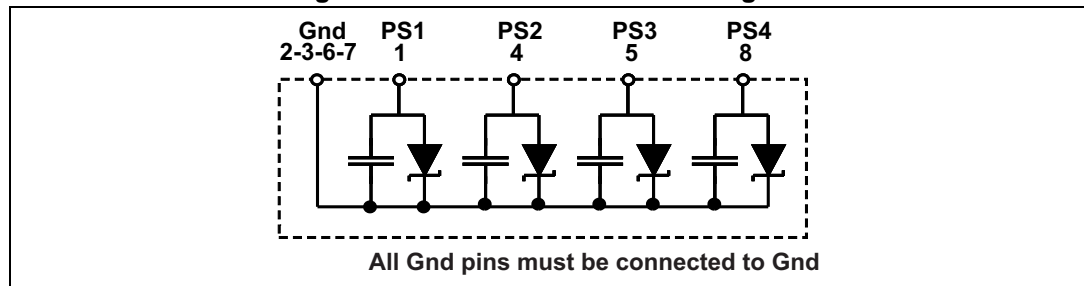

As the PEP01-5841 has been designed to protect against IEC61000-4-5, specified current capability (I_{PP}) of each cell is 24 A ([Figure 8](#)).

This complies with the I_{PP} protection requirement (capability to withstand the surge).

Table 3. Electrical characteristics - values ($T_{amb} = 25\text{ °C}$)

Type	$I_{RM} \text{ max @ } V_{RM}$			$V_{BR} \text{ @ } I_R^{(1)}$				8/20 μs		
								$V_{CL} \text{ @ } I_{PP}$		$R_D^{(2)}$
	25 °C	85 °C		min.	typ.	max.		max.		
	μA	μA	V	V			mA	V	A	Ω
PEP01-5841	0.2	1	58	64.4	67.8	71.2	1	100	24	1.2

1. Pulse test: $t_p < 50 \text{ ms}$

2. To calculate maximum clamping voltage at other surge level, use the following formula:
 $V_{CLmax} = R_D \times I_{PP} + V_{BRmax}$

The capability to protect is achieved with the V_{CL} max limited to 100 V. The reason for the 100 V max is to avoid failure of the Pmos or the PSE controller generally using a technology typically around 110 or 120 V rated 100 V in the datasheet.

5 Conclusion

In most countries it is mandatory to comply with the IEC 61000-4 series.

Most of the protection devices are rated with ESD capability but only a few of them are rated with the surge corresponding to IEC 61000-4-5. Using the correct protection designed to comply with IEC 61000-4-5 is an insurance to get reliable equipment and to avoid costly quality field returns to keep a good brand image.

ST has developed a range of devices rated according to IEC 61000-4-5. For more information, go to the ST.COM web site and follow the links to the products for power discretes and modules for protection devices. IEC 61000-4-5 compliant devices are listed under EOS 8/20 microsecond surge protection (see [Figure 9](#)).

Figure 9. EOS 8/20 μ s surge protection

The screenshot shows the ST website page for EOS 8/20 microsecond surge protection. The page features a navigation menu with links for Home, Products, Applications, Support, Sample & Buy, About, Contact, and My ST Login. A search bar is located in the top right corner. The main content area includes a title 'EOS 8/20 microsecond surge protection' and a description of ST's EOS 8/20 μ s power surge protectors and suppressors. A chart titled 'IEC 61000-4-5 industrial classes' shows serial resistance for datalines and power lines across different surge voltage classes (Class 1 to Class 4).

Surge voltage	Datalines Serial resistance	Power lines Serial resistance
500 V (Class 1)	42 Ω	12 Ω
1000 V (Class 2)	42 Ω	12 Ω
2000 V (Class 3)	42 Ω	12 Ω
4000 V (Class 4)	42 Ω	12 Ω
6000 V	42 Ω	12 Ω

The use of an IEC 61000-4-5 rated protection limits the number of tests to be performed before certification, saves cost and time and reduces the number of quality returns.

6 Revision history

Table 4. Document revision history

Date	Revision	Changes
06-Aug-2013	1	Initial release.

Please Read Carefully:

Information in this document is provided solely in connection with ST products. STMicroelectronics NV and its subsidiaries ("ST") reserve the right to make changes, corrections, modifications or improvements, to this document, and the products and services described herein at any time, without notice.

All ST products are sold pursuant to ST's terms and conditions of sale.

Purchasers are solely responsible for the choice, selection and use of the ST products and services described herein, and ST assumes no liability whatsoever relating to the choice, selection or use of the ST products and services described herein.

No license, express or implied, by estoppel or otherwise, to any intellectual property rights is granted under this document. If any part of this document refers to any third party products or services it shall not be deemed a license grant by ST for the use of such third party products or services, or any intellectual property contained therein or considered as a warranty covering the use in any manner whatsoever of such third party products or services or any intellectual property contained therein.

UNLESS OTHERWISE SET FORTH IN ST'S TERMS AND CONDITIONS OF SALE ST DISCLAIMS ANY EXPRESS OR IMPLIED WARRANTY WITH RESPECT TO THE USE AND/OR SALE OF ST PRODUCTS INCLUDING WITHOUT LIMITATION IMPLIED WARRANTIES OF MERCHANTABILITY, FITNESS FOR A PARTICULAR PURPOSE (AND THEIR EQUIVALENTS UNDER THE LAWS OF ANY JURISDICTION), OR INFRINGEMENT OF ANY PATENT, COPYRIGHT OR OTHER INTELLECTUAL PROPERTY RIGHT.

ST PRODUCTS ARE NOT AUTHORIZED FOR USE IN WEAPONS. NOR ARE ST PRODUCTS DESIGNED OR AUTHORIZED FOR USE IN: (A) SAFETY CRITICAL APPLICATIONS SUCH AS LIFE SUPPORTING, ACTIVE IMPLANTED DEVICES OR SYSTEMS WITH PRODUCT FUNCTIONAL SAFETY REQUIREMENTS; (B) AERONAUTIC APPLICATIONS; (C) AUTOMOTIVE APPLICATIONS OR ENVIRONMENTS, AND/OR (D) AEROSPACE APPLICATIONS OR ENVIRONMENTS. WHERE ST PRODUCTS ARE NOT DESIGNED FOR SUCH USE, THE PURCHASER SHALL USE PRODUCTS AT PURCHASER'S SOLE RISK, EVEN IF ST HAS BEEN INFORMED IN WRITING OF SUCH USAGE, UNLESS A PRODUCT IS EXPRESSLY DESIGNATED BY ST AS BEING INTENDED FOR "AUTOMOTIVE, AUTOMOTIVE SAFETY OR MEDICAL" INDUSTRY DOMAINS ACCORDING TO ST PRODUCT DESIGN SPECIFICATIONS. PRODUCTS FORMALLY ESCC, QML OR JAN QUALIFIED ARE DEEMED SUITABLE FOR USE IN AEROSPACE BY THE CORRESPONDING GOVERNMENTAL AGENCY.

Resale of ST products with provisions different from the statements and/or technical features set forth in this document shall immediately void any warranty granted by ST for the ST product or service described herein and shall not create or extend in any manner whatsoever, any liability of ST.

ST and the ST logo are trademarks or registered trademarks of ST in various countries.

Information in this document supersedes and replaces all information previously supplied.

The ST logo is a registered trademark of STMicroelectronics. All other names are the property of their respective owners.

© 2013 STMicroelectronics - All rights reserved

STMicroelectronics group of companies

Australia - Belgium - Brazil - Canada - China - Czech Republic - Finland - France - Germany - Hong Kong - India - Israel - Italy - Japan - Malaysia - Malta - Morocco - Philippines - Singapore - Spain - Sweden - Switzerland - United Kingdom - United States of America

www.st.com

