

# XC800

Microcontroller Family

Architecture and Instruction Set

# 8bit

Microcontrollers



Never stop thinking.

**Edition 2005-01**

**Published by Infineon Technologies AG,  
St.-Martin-Strasse 53,  
81669 München, Germany**

**© Infineon Technologies AG 2005.  
All Rights Reserved.**

**Attention please!**

The information herein is given to describe certain components and shall not be considered as a guarantee of characteristics.

Terms of delivery and rights to technical change reserved.

We hereby disclaim any and all warranties, including but not limited to warranties of non-infringement, regarding circuits, descriptions and charts stated herein.

**Information**

For further information on technology, delivery terms and conditions and prices please contact your nearest Infineon Technologies Office ([www.infineon.com](http://www.infineon.com)).

**Warnings**

Due to technical requirements components may contain dangerous substances. For information on the types in question please contact your nearest Infineon Technologies Office.

Infineon Technologies Components may only be used in life-support devices or systems with the express written approval of Infineon Technologies, if a failure of such components can reasonably be expected to cause the failure of that life-support device or system, or to affect the safety or effectiveness of that device or system. Life support devices or systems are intended to be implanted in the human body, or to support and/or maintain and sustain and/or protect human life. If they fail, it is reasonable to assume that the health of the user or other persons may be endangered.

# XC800

Microcontroller Family

Architecture and Instruction Set

Microcontrollers



Never stop thinking.

---

**XC800****Revision History:        2005-01**

V 0.1

Previous Version:        -

| Page | Subjects (major changes since last revision) |
|------|--|
|      |  |
|      |  |
|      |  |
|      |  |
|      |  |
|      |  |
|      |  |
|      |  |
|      |  |
|      |  |
|      |  |

**We Listen to Your Comments**

Any information within this document that you feel is wrong, unclear or missing at all?  
Your feedback will help us to continuously improve the quality of this document.

Please send your proposal (including a reference to this document) to:

[mcdocu.comments@infineon.com](mailto:mcdocu.comments@infineon.com)



| <b>Table of Contents</b> |  | <b>Page</b> |
|--------------------------|--|-------------|
| <b>1</b>                 | <b>Fundamental Structure</b> .....                   | <b>1</b>    |
| 1.1                      | Foreword .....                                       | 1           |
| 1.2                      | Introduction .....                                   | 1           |
| 1.3                      | Memory Organization .....                            | 2           |
| 1.3.1                    | Memory Extension .....                               | 3           |
| 1.3.1.1                  | Memory Extension Stack .....                         | 3           |
| 1.3.1.2                  | Memory Extension Effects .....                       | 3           |
| 1.3.2                    | Program Memory .....                                 | 5           |
| 1.3.3                    | Data Memory .....                                    | 5           |
| 1.3.3.1                  | Internal Data Memory .....                           | 5           |
| 1.3.3.2                  | Internal Data Memory XRAM .....                      | 6           |
| 1.3.3.3                  | External Data Memory .....                           | 6           |
| 1.3.4                    | Registers .....                                      | 6           |
| 1.3.4.1                  | Special Function Register Extension by Mapping ..... | 7           |
| 1.3.4.2                  | Special Function Register Extension by Paging .....  | 8           |
| 1.4                      | Bit Protection Scheme .....                          | 11          |
| <b>2</b>                 | <b>CPU Architecture</b> .....                        | <b>1</b>    |
| 2.1                      | CPU Register Description .....                       | 4           |
| 2.1.1                    | Stack Pointer (SP) .....                             | 4           |
| 2.1.2                    | Data Pointer (DPTR) .....                            | 4           |
| 2.1.3                    | Accumulator (ACC) .....                              | 4           |
| 2.1.4                    | B Register .....                                     | 4           |
| 2.1.5                    | Program Status Word .....                            | 5           |
| 2.1.6                    | Extended Operation Register (EO) .....               | 6           |
| 2.1.7                    | Memory Extension Registers .....                     | 7           |
| 2.1.8                    | Power Control Register (PCON) .....                  | 9           |
| 2.1.9                    | UART Registers .....                                 | 10          |
| 2.1.10                   | Timer/Counter Registers .....                        | 12          |
| 2.1.11                   | Interrupt Registers .....                            | 14          |
| 2.2                      | On-Chip Debug Support Concept .....                  | 18          |
| 2.3                      | Basic Interrupt Handling .....                       | 20          |
| 2.3.1                    | Interrupt Source and Vector Address .....            | 20          |
| 2.3.2                    | Interrupt Handling .....                             | 20          |
| 2.4                      | Interrupt Response Time .....                        | 21          |
| 2.5                      | Service Order .....                                  | 22          |
| <b>3</b>                 | <b>CPU Timing</b> .....                              | <b>1</b>    |
| 3.1                      | Instruction Timing .....                             | 1           |
| 3.2                      | Accessing External Memory .....                      | 3           |
| 3.2.1                    | Accessing External Program Memory .....              | 3           |
| 3.2.2                    | Accessing External Data Memory .....                 | 4           |

---

| <b>Table of Contents</b> |   | <b>Page</b> |
|--------------------------|---|-------------|
| <b>4</b>                 | <b>Instruction Set</b> .....              | <b>1</b>    |
| 4.1                      | Addressing Modes .....                    | 1           |
| 4.2                      | Introduction to the Instruction Set ..... | 3           |
| 4.3                      | Instructions .....                        | 5           |
| 4.3.1                    | Affected Flags .....                      | 5           |
| 4.3.2                    | Instruction Table .....                   | 6           |
| 4.3.3                    | Instruction Definitions .....             | 11          |

# 1 Fundamental Structure

## 1.1 Foreword

This manual provides an overview of the architecture and functional characteristics of the XC800 microcontroller family. It also includes a complete description of the XC800 core instruction set. For detailed information on the different derivatives of the XC800 8-bit microcontrollers, refer to the respective user's manuals.

## 1.2 Introduction

The Infineon XC800 microcontroller family has a CPU which is functionally upward compatible to the 8051. While the standard 8051 core is designed around a 12-clock machine cycle, the XC800 core uses a two-clock period machine cycle.

The instruction set consists of 45% one-byte, 41% two-byte, and 14% three-byte instructions. Each instruction takes 1, 2 or 4 machine cycles to execute. In case of access to slower memory, the access time may be extended by wait states.

The XC800 microcontrollers support via the dedicated JTAG interface or the standard UART interface, a range of debugging features including basic stop/start, single-step execution, breakpoint support and read/write access to the data memory, program memory and special function registers.

The key features of the XC800 microcontrollers are listed below.

### Features:

- Two clocks per machine cycle
- Program memory download option
- Up to 1 Mbyte of external data memory; up to 256 bytes of internal data memory
- Up to 1 Mbyte of program memory
- Wait state support for slow memory
- Support for synchronous or asynchronous program and data memory
- 15-source, 4-level interrupt controller
- Up to eight data pointers
- Power saving modes
- Dedicated debug mode via the standard JTAG interface or UART
- Two 16-bit timers (Timer 0 and Timer 1)
- Full-duplex serial port (UART)

### 1.3 Memory Organization

The memory partitioning of the XC800 microcontrollers is typical of the Harvard architecture where data and program areas are held in separate memory space. The on-chip peripheral units are accessed using an internal Special Function Register (SFR) memory area that occupies 128 bytes of address, which can be mapped or paged to increase the number of addressable SFRs.

A typical memory map of the code space consists of internal ROM/Flash, on-chip Boot ROM, an on-chip XRAM and/or external memory. The memory map of the data space is typical of the standard 8051 architecture: the internal data memory consists of 128 bytes of directly addressable Internal RAM (IRAM), 128 bytes of indirect addressable IRAM and an 'external' RAM (XRAM). External data memory may be supported outside of the internal range. **Figure 1-1** provides a general overview of the XC800 memory space and a typical memory map in user mode.

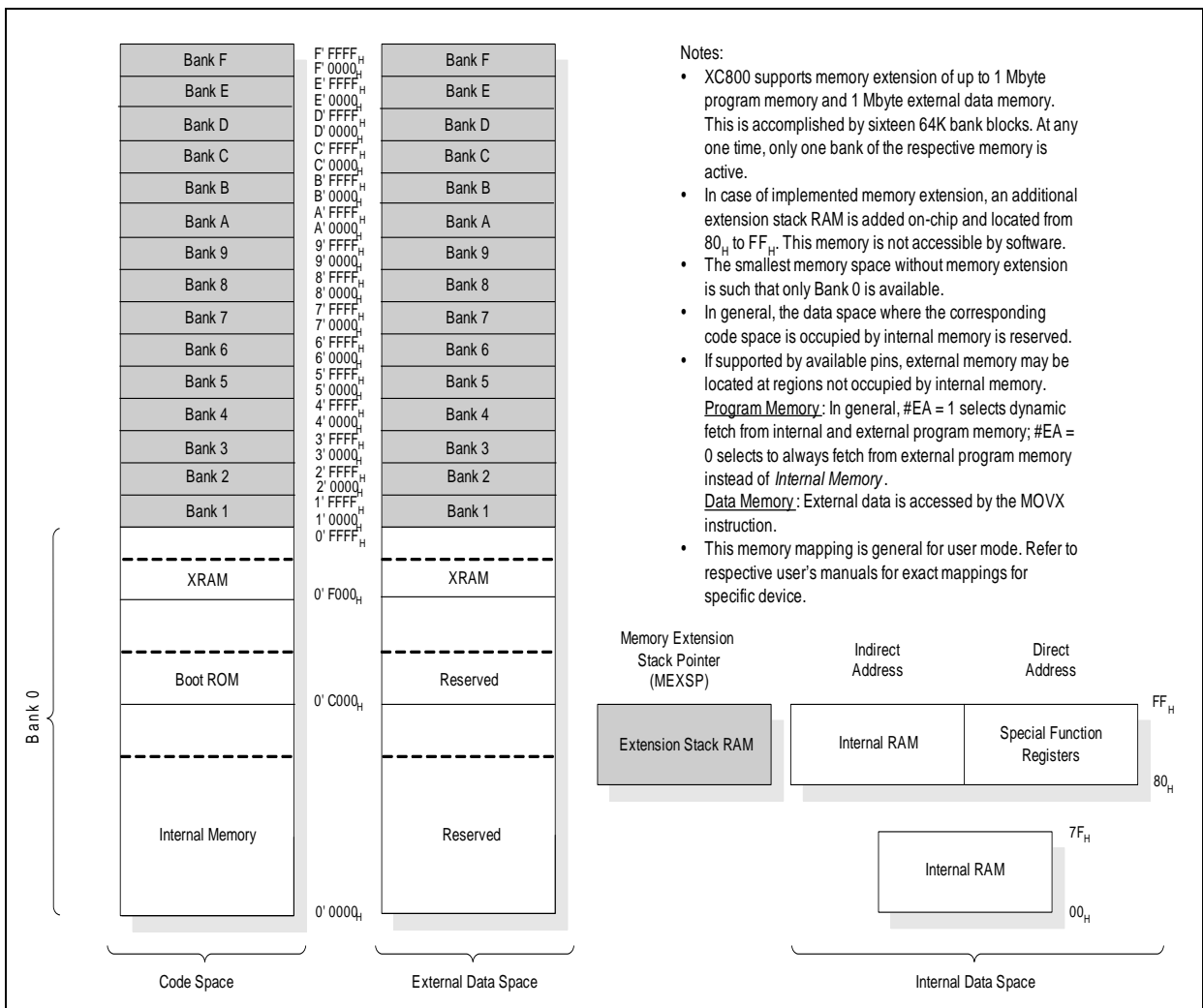

Figure 1-1 XC800 Memory Space and Typical Memory Map in user mode



In derivatives with memory extension, an additional 128 bytes of memory extension stack RAM is available from  $80_H$  to  $FF_H$ . Access to this memory is only possible by the hardware, so the memory is effectively transparent to the user. By default after reset, the memory extension stack pointer (MEXSP) points to  $7F_H$ . It is pre-incremented by call instructions and post-decremented by return instructions.

### **1.3.1 Memory Extension**

The standard amount of addressable program or external data memory in an 8051 system is 64 Kbytes. The XC800 core supports memory expansion of up to 1 Mbyte and this is enabled by the availability of a Memory Management Unit (MMU) and a Memory Extension Stack. The MMU adds a set of Memory Extension registers (MEX1, MEX2, and MEX3) to control access to the extended memory space by different addressing modes. The Memory Extension Stack is used by the hardware to 'push' and 'pop' values of MEX1.

Program Code is always fetched from the 64-Kbyte block pointed to by the 4-bit Current Bank (CB) register bit field. It is updated from a 4-bit Next Bank (NB) bit field upon execution of long jump (LJMP) and call instructions. CB and NB together constitute the MEX1 register. The programmer simply writes the new bank number to NB before a jump or call instruction.

Interrupt service routines are always executed from code in the 64-Kbyte block pointed to by the Interrupt Bank (IB) register bit field. Further, memory constant data reads (in code space) and external data accesses may take place in banks other than the current bank. These banks are pointed to by the Memory Constant Bank pointer (MCB) and XRAM Bank pointer (MX). These bit fields are located in MEX2 and MEX3 registers.

#### **1.3.1.1 Memory Extension Stack**

Interrupts and Calls in Memory Extension mode make use of a Memory Extension Stack, which is updated at the same time as the standard stack.

The Memory Extension Stack is addressed using the SFR Memory Extension Stack Pointer MEXSP. This read/write register provides for a stack depth of up to 128 bytes (Bit 7 is always 0). The SFR is pre-incremented by each call instruction that is executed, and post-decremented by return instructions. MEXSP is by default reset to  $7F_H$  so that the first increment selects the bottom of the stack. No indication of stack overflow is provided.

#### **1.3.1.2 Memory Extension Effects**

The following instructions can change the 64-Kbyte block pointed to: MOVC, MOVX, LJMP, LCALL, ACALL, RET, and RETI.

---

## Fundamental Structure

Relative jumps (SJMP etc.) and absolute jumps within 2-Kbyte regions (AJMPs), however, will in no way change the current bank. In other words, these instructions do not deselect the active 64-Kbyte bank block.

### Move Constant Instructions (MOVC)

MOVC instructions access data bytes in either the Current bank (CB19 – CB16) or a 'Memory Constant' bank, defined by the MCB19 – MCB16 bit field in MEX3 and MEX2. The bank selection is done by the MCM bit in MEX2 (MEX2.7).

### Move External Data Instructions (MOVX)

MOVX instructions can either access data in the Current bank or a 'Data Memory' bank, defined by the MX19 – MX16 bits in MEX3. The bank selection is done by the MXM bit in MEX3 (MEX3.3).

### Long Jump Instructions (LJMP)

When a jump to another bank of the Memory Extension is required, the Next Bank bits NB19 – NB16 in MEX1 (MEX1.3 – MEX1.0) must be set to the appropriate bank address before the LJMP instruction is executed. When the LJMP is encountered in the code, the Next Bank bits (NB19 – 16) are copied to the Current Bank bits CB19 – CB16 in MEX1 (MEX1.7 – MEX1.4) and appear on address bus at the beginning of the next program fetch cycle.

*Note: The Next Bank Bits (NB19 – 16) are not changed by the jump.*

### CALL Instructions (LCALL and ACALL)

Whenever an LCALL occurs, the MMU carries out the following sequence of actions:

1. The Memory Extension Stack Pointer is incremented.
2. The MEX1 register bits are made available on data bus.
3. The MEXSP register bits [6:0] are made available on address lines.
4. The Memory Extension Stack read and write signals are set for a write operation.
5. A write is performed to the Memory Extension Stack.
6. The Next Bank bits NB19 – NB16 (MEX1.3 – MEX1.0) are copied to the CB19 – CB16 bits (MEX1.7 – MEX1.4).

### Return Instructions (RET and RETI)

On leaving a subroutine, the MMU carries out the following sequence of actions:

1. The MEXSP register bits [6:0] are made available on address.
2. The Memory Extension Stack read and write signals are set for a read operation.
3. A read is performed on the Memory Extension Stack.
4. Memory Extension Stack data is written to the MEX1 register.
5. The Memory Extension Stack Pointer is decremented.

### 1.3.2 Program Memory

Up to 1 Mbyte of synchronous or asynchronous internal and/or external program memory is supported. Program memory extension, if supported by the XC800 derivative, is accomplished with a 4-bit Current Bank pointer (CB). The program code is fetched from the 64-Kbyte block pointed to by CB. The minimum supported code space is therefore 64 Kbytes.

If the internal program memory is used, the  $\overline{EA}$  (External Access) pin must be held at high level. With  $\overline{EA}$  held high, the microcontroller executes instructions internally unless the address (Program Counter) is outside the range of the internal program memory. In this case, dynamic code fetch from internal and external program memory is supported if the external memory bus is available on the derivative. If the  $\overline{EA}$  pin is held at low level, the microcontroller executes program code from external program memory, instead of from internal memory. The general exception is for accesses to address ranges of the active Boot ROM, internal XRAM and code-space data (e.g., Data Flash), where fetch is always from the internal memory regardless of the status of  $\overline{EA}$  pin.

Most XC800 derivatives include a section for Boot ROM code, the size of which depends on the derivative. Usually, the Boot ROM code is executed first after reset where the Boot ROM is mapped starting from base address 0000<sub>H</sub> of the code space. The Boot ROM code will switch the memory mapping so that before control is passed to the user code, the standard memory map (of the derivative) is active where user code could run starting from address 0000<sub>H</sub>.

For program memory implemented as RAM, the XC800 core supports write to program memory with the instruction *MOVC @(DPTR++),A*. This is generally supported by the XC800 derivatives for writes to internal memory only.

### 1.3.3 Data Memory

The data memory space consists of internal and external memory portions. The internal data memory area is addressed using 8-bit addresses. The external data memory and the internal XRAM data memory are addressable by 8-bit or 16-bit indirect address with 'MOVX', additionally with up to 4-bit for selection of extended memory bank (maximum 1 Mbyte).

#### 1.3.3.1 Internal Data Memory

The internal data memory is divided into two physically separate and distinct blocks: the 256-byte RAM and the 128-byte SFR area. While the upper 128 bytes of RAM and the SFR area share the same address locations, they are accessed through different addressing modes. The lower 128 bytes of RAM can be accessed through either direct or register indirect addressing while the upper 128 bytes of RAM can be accessed through register indirect addressing only. The special function registers are accessible through direct addressing.

The 16 bytes of RAM that occupy addresses from  $20_H$  to  $2F_H$  are bitaddressable. Bit 0 of the internal data byte at  $20_H$  has the bit address  $00_H$ , while bit 7 of the internal data byte at  $2F_H$  has the bit address  $7F_H$ .

By default after reset, the stack pointer points to address  $07_H$ . The stack may reside anywhere in the internal RAM.

RAM occupying direct addresses from  $30_H$  to  $7F_H$  can be used as scratch pad.

### 1.3.3.2 Internal Data Memory XRAM

The size of the internal XRAM is not fixed and varies depending on XC800 derivative. The internal XRAM is mapped to both the external data space and the code space because it can be accessed using both 'MOVX' and 'MOVC' instructions. When accessed using the 8-bit MOVX instruction via register R0 or R1, the SFR XADDRH must be initialized to specify the upper address byte.

The internal XRAM can be enabled or disabled. If disabled, external data memory can be accessed in the address range of the internal XRAM, with activated external data memory signals. If enabled, the external data memory signals are not generated when the internal XRAM is accessed. Therefore, the corresponding ports can be used as general purpose I/O in an application where there is no access to off-chip external data/program memory.

### 1.3.3.3 External Data Memory

Up to 1 Mbyte of synchronous or asynchronous external data memory is supported. External data memory extension, if supported by the XC800 derivative, is accomplished with either the 4-bit Current Bank pointer (CB) or the 4-bit XRAM Bank pointer (MX), selected by the MXM bit. The data is fetched from the 64-Kbyte block pointed to by CB or MX. Some XC800 derivatives may not support external data memory.

## 1.3.4 Registers

All registers, except the program counter and the four general purpose register banks, reside in the SFR area.

The lower 32 locations of the internal lower data RAM are assigned to four banks with eight general purpose registers (GPRs) each. At any one time, only one of these banks can be enabled by two bits in the program status word (PSW): RS0 (PSW.3) and RS1 (PSW.4). This allows fast context switching, which is useful when entering subroutines or interrupt service routines. The eight general purpose registers of the selected register bank may be accessed by register addressing. For indirect addressing modes, the registers R0 and R1 are used as pointer or index register to address internal or external memory.

**Fundamental Structure**

The Special Function Registers (SFRs) are mapped to the internal data space in the range 80<sub>H</sub> to FF<sub>H</sub>. The SFRs are accessible through direct addressing. The SFRs that are located at addresses with address bit 0-2 equal to 0 (addresses 80<sub>H</sub>, 88<sub>H</sub>, 90<sub>H</sub>, ..., F8<sub>H</sub>) are bitaddressable. Each bit of the bitaddressable SFRs has bit address corresponding to the SFR byte address and its position within the SFR byte. For example, bit 7 of SFR at byte address 80<sub>H</sub> has a bit address of 87<sub>H</sub>. The bit addresses of the SFR bits span from 80<sub>H</sub> to FF<sub>H</sub>.

As the 128-SFR range is less than the total number of registers required, register extension mechanisms are implemented to increase the number of addressable SFRs. These mechanisms include:

- Mapping
- Paging

**1.3.4.1 Special Function Register Extension by Mapping**

SFR extension is performed at the system level by mapping. The SFR area is extended into two portions: the standard (non-mapped) SFR area and the mapped SFR area. Each portion supports the same address range 80<sub>H</sub> to FF<sub>H</sub>, bringing the number of addressable SFRs to 256. To access SFRs in the mapped area, bit RMAP in SFR SYSCON0 must be set by software. The mapped SFR area provides the same addressing capabilities (direct addressing, bit addressing) as the standard SFR area. Bit RMAP must be cleared by software to access the SFRs in the standard area. The hardware does not automatically clear/set the bit.

**SYSCON0**

**System Control Register 0**

**Reset Value: XXXX XXX0<sub>B</sub>**

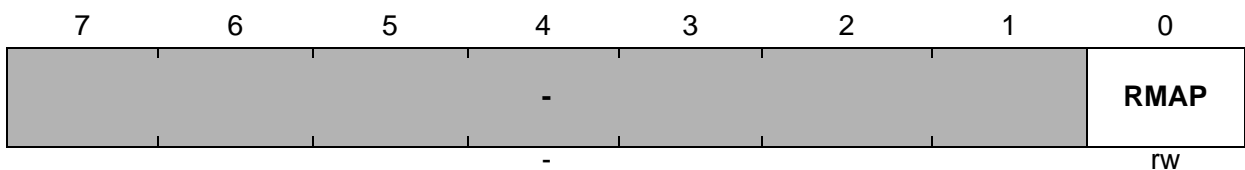

The functions of the shaded bits are not described here

| Field       | Bits | Type | Description   |
|-------------|------|------|---|
| <b>RMAP</b> | 0    | rw   | <p><b>Special Function Register Map Control</b></p> <p>0 The access to the standard SFR area is enabled.</p> <p>1 The access to the mapped SFR area is enabled.</p> |

### 1.3.4.2 Special Function Register Extension by Paging

The number of SFRs may be further extended for some on-chip peripherals at the module level via a paging scheme. These peripherals have a built-in local SFR extension mechanism for increasing the number of addressable SFRs. The control is via bit field PAGE in the module page register MOD\_PAGE. The bit field PAGE must be programmed before accessing the SFR of the target module. Each module may contain different number of pages and different number of SFRs per page, depending on the requirement. Besides setting the correct RMAP bit value to select the standard or mapped SFR area, the user must also ensure that a valid PAGE is selected to access the desired SFR. The paging mechanism is illustrated in [Figure 1-2](#).

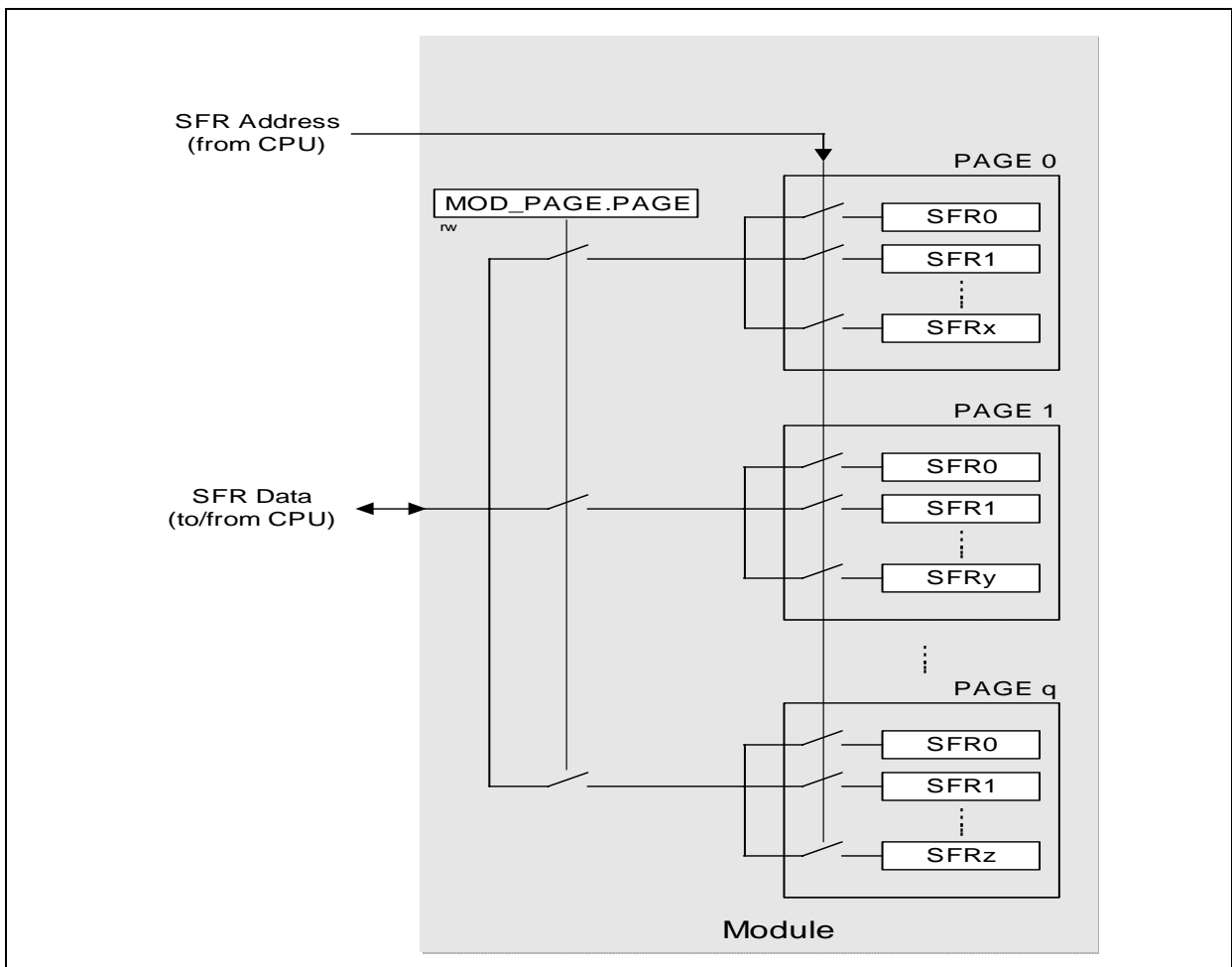

**Figure 1-2 SFR Extension by Paging**

If an interrupt routine is initiated between the page register access and the module register access, and the interrupt must access a register located in another page, the current page setting can be saved, the new one programmed and finally, the old page setting restored. This is possible with the storage fields STx (x = 0 - 3) for the save and restore action of the current page setting, as illustrated in [Figure 1-3](#). By indicating which

**Fundamental Structure**

storage register should be used in parallel with the new page value, a single write operation can:

- Save the contents of PAGE in STx before overwriting with the new value (this is done in the beginning of the interrupt routine to save the current page setting and program the new page number); or
- Overwrite the contents of PAGE with the contents of STx, ignoring the value written to the bit positions of PAGE (this is done at the end of the interrupt routine to restore the previous page setting before the interrupt occurred)

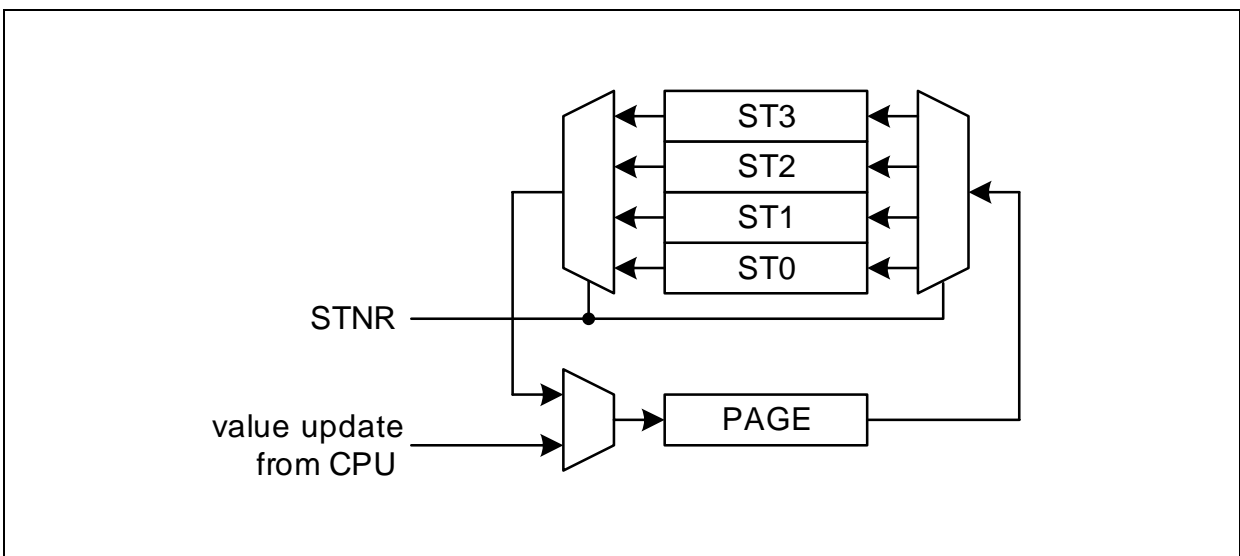

**Figure 1-3 Storage Elements for Paging**

With this mechanism, a certain number of interrupt routines (or other routines) can perform page changes without reading and storing the previously used page information. The use of only write operations makes the system simpler and faster. Consequently, this mechanism significantly improves the performance of short interrupt routines.

The page register has the following definition:

**MOD\_PAGE**

**Page Register for module MOD**

**Reset Value: 00<sub>H</sub>**

|           |   |             |   |          |             |   |   |
|-----------|---|-------------|---|----------|-------------|---|---|
| 7         | 6 | 5           | 4 | 3        | 2           | 1 | 0 |
| <b>OP</b> |   | <b>STNR</b> |   | <b>0</b> | <b>PAGE</b> |   |   |
| W         |   | W           |   | r        | rW          |   |   |

**Fundamental Structure**

| Field       | Bits  | Type | Description   |
|-------------|-------|------|---|
| <b>PAGE</b> | [2:0] | rw   | <b>Page Bits</b><br>When written, the value indicates the new page.<br>When read, the value indicates the currently active page.  |
| <b>STNR</b> | [5:4] | w    | <b>Storage Number</b><br>This number indicates which storage bit field is the target of the operation defined by bit field OP.<br>If OP = 10 <sub>B</sub> ,<br>the contents of PAGE are saved in STx before being overwritten with the new value.<br>If OP = 11 <sub>B</sub> ,<br>the contents of PAGE are overwritten by the contents of STx. The value written to the bit positions of PAGE is ignored.<br><br>00 ST0 is selected.<br>01 ST1 is selected.<br>10 ST2 is selected.<br>11 ST3 is selected.   |
| <b>OP</b>   | [7:6] | w    | <b>Operation</b><br>0X Manual page mode. The value of STNR is ignored and PAGE is directly written.<br>10 New page programming with automatic page saving. The value written to the bit field PAGE is stored. In parallel, the previous contents of PAGE are saved in the storage bit field STx indicated by STNR.<br>11 Automatic restore page action. The value written to the bit field PAGE is ignored and instead, PAGE is overwritten by the contents of the storage bit field STx indicated by STNR. |
| <b>0</b>    | 3     | r    | <b>Reserved</b><br>Returns 0 if read; should be written with 0.   |



### 1.4 Bit Protection Scheme

The bit protection scheme prevents direct software writing of selected bits (i.e., protected bits) by the PASSWD register. When the bit field MODE is 11<sub>B</sub>, writing 10011<sub>B</sub> to the bit field PASS opens access to writing of all protected bits and writing 10101<sub>B</sub> to the bit field PASS closes access to writing of all protected bits. Note that access is opened for maximum 32 CCLKs if the “close access” password is not written. If “open access” password is written again before the end of 32 CCLK cycles, there will be a recount of 32 CCLK cycles.

The bits or bit fields that are protected may differ for the XC800 derivatives.

#### PASSWD

##### Password Register

Reset Value: 07<sub>H</sub>

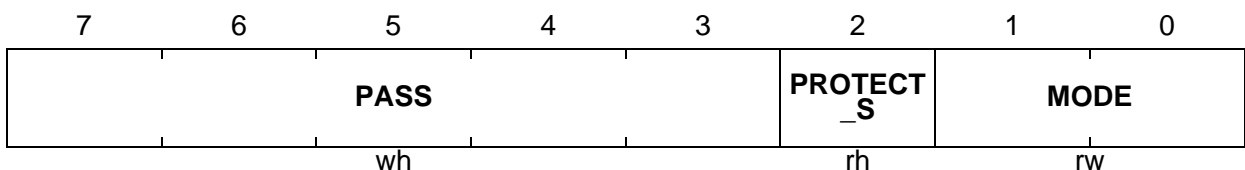

| Field            | Bits  | Type | Description  |
|------------------|-------|------|--|
| <b>MODE</b>      | [1:0] | rw   | <b>Bit-Protection Scheme Control bit</b><br>00 Scheme Disabled<br>11 Scheme Enabled (default)<br>Others: Scheme Enabled<br>These two bits cannot be written directly. To change the value between 11 <sub>B</sub> and 00 <sub>B</sub> , the bit field PASS must be written with 11000 <sub>B</sub> , only then will the MODE[1:0] be registered. |
| <b>PROTECT_S</b> | 2     | rh   | <b>Bit-Protection Signal Status bit</b><br>This bit shows the status of the protection.<br>0 Software is able to write to all protected bits.<br>1 Software is unable to write to any protected bits.  |
| <b>PASS</b>      | [7:3] | wh   | <b>Password bits</b><br>The Bit-Protection Scheme recognizes only three patterns.<br>11000 <sub>B</sub> Enables writing of the bit field MODE.<br>10011 <sub>B</sub> Opens access to writing of all protected bits.<br>10101 <sub>B</sub> Closes access to writing of all protected bits.  |

## 2 CPU Architecture

**Figure 2-1** depicts the typical architecture of an XC800 family microcontroller. It includes the main functional blocks and standard units. The units represented by dotted boxes may not be available, depending on the derivative; these include peripheral units and external memory bus. Memory sizes vary depending on the XC800 microcontroller derivative.

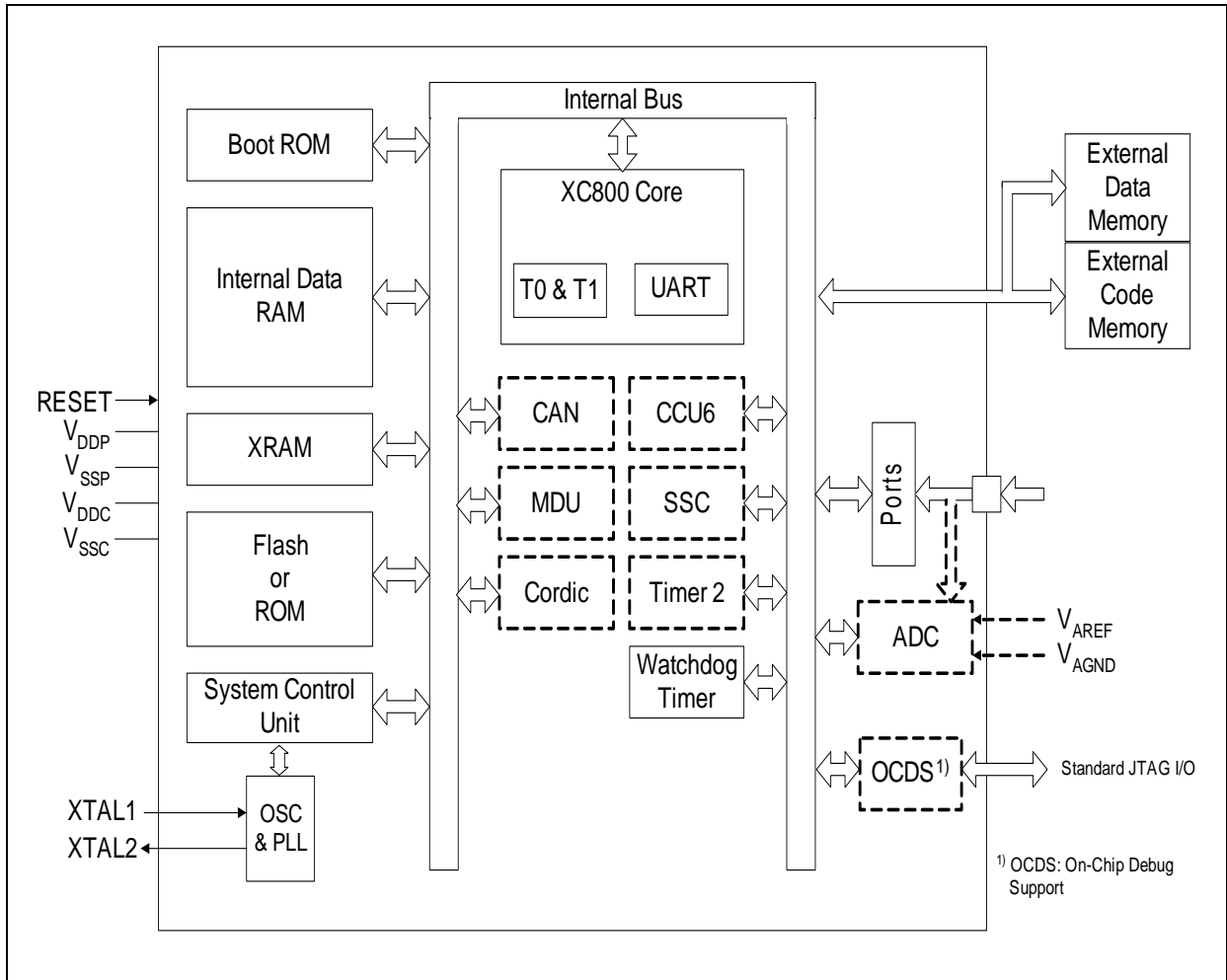

**Figure 2-1 Typical Architecture of XC800 Family Microcontroller**

The CPU functional blocks are shown in **Figure 2-2**. The CPU consists mainly of the instruction decoder, the arithmetic section, the program control section, the access control section, and the interrupt controller. The CPU also provides modes for power saving.

The instruction decoder decodes each instruction and accordingly generates the internal signals required to control the functions of the individual units within the CPU. These internal signals have an effect on the source and destination of signal transfers and control the ALU processing.

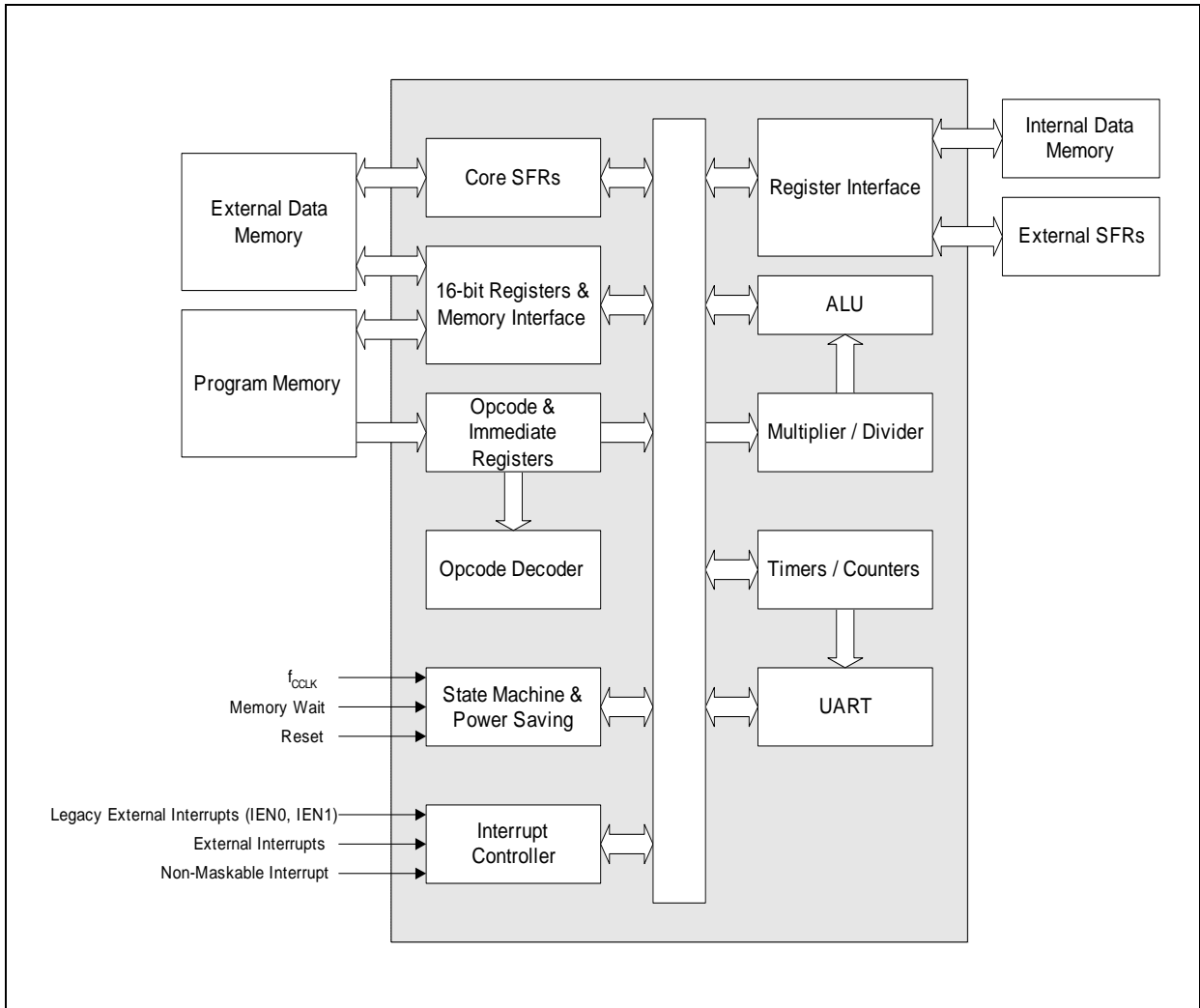

**Figure 2-2 XC800 Core Block Diagram**

The arithmetic section of the processor performs extensive data manipulation and consists of the arithmetic/logic unit (ALU), A register, B register, and PSW register. The ALU accepts 8-bit data words from one or two sources, and generates an 8-bit result under the control of the instruction decoder. The ALU performs both arithmetic and logic operations. Arithmetic operations include add, subtract, multiply, divide, increment, decrement, BCD-decimal-add-adjust, and compare. Logic operations include AND, OR, Exclusive OR, complement, and rotate (right, left, or swap nibble (left four)). Also included is a Boolean unit performing the bit operations such as set, clear, complement, jump-if-set, jump-if-not-set, jump-if-set-and-clear, and move to/from carry. The ALU can perform the bit operations of logical AND or logical OR between any addressable bit (or its complement) and the carry flag, and place the new result in the carry flag.

The program control section controls the sequence in which the instructions stored in program memory are executed. The 16-bit program counter (PC) holds the address of

---

**CPU Architecture**

the next instruction to be executed. The conditional branch logic enables internal and external events to the processor to cause a change in the program execution sequence. The access control unit is responsible for the selection of the on-chip memory resources. The interrupt requests from the peripheral units are handled by the interrupt controller unit.

## 2.1 CPU Register Description

The CPU registers occupy direct Internal Data Memory space locations in the range 80<sub>H</sub> to FF<sub>H</sub>.

### 2.1.1 Stack Pointer (SP)

The SP register contains the Stack Pointer. The Stack Pointer is used to load the program counter into Internal Data Memory during LCALL and ACALL instructions, and to retrieve the program counter from memory during RET and RETI instructions. Data may also be saved on or retrieved from the stack using PUSH and POP instructions. Instructions that use the stack automatically pre-increment or post-decrement the stack pointer so that the stack pointer always points to the last byte written to the stack, i.e. the top of the stack. On reset, the Stack Pointer is reset to 07<sub>H</sub>. This causes the stack to begin at a location = 08<sub>H</sub> above register bank zero. The SP can be read or written under software control. The programmer must ensure that the location and size of the stack in internal data memory do not interfere with other application data.

### 2.1.2 Data Pointer (DPTR)

The Data Pointer (DPTR) is stored in registers DPL (Data Pointer Low byte) and DPH (Data Pointer High byte) to form 16-bit addresses for External Data Memory accesses (MOVX A,@DPTR and MOVX @DPTR,A), for program byte moves (MOVC A,@A+DPTR), and for indirect program jumps (JMP @A+DPTR).

Two true 16-bit operations are allowed on the Data Pointer: load immediate (MOV DPTR,#data) and increment (INC DPTR).

The CPU can support up to 8 data pointers. This helps programming in high level languages, which may require the storing of data in large external data memory portions. Selection of the active data pointer is done via the SFR EO (see [Section 2.1.6](#)). The number of data pointers available is specific to the XC800 derivative.

### 2.1.3 Accumulator (ACC)

This register is an operand for most ALU operations. ACC is the symbol for the accumulator register. The mnemonics for accumulator-specific instructions, however, refer to the accumulator simply as "A".

### 2.1.4 B Register

The B register is used during multiply and divide operations to provide the second operand. For other instructions, it can be treated as another scratch pad register.

## 2.1.5 Program Status Word

The Program Status Word (PSW) contains several status bits that reflect the current state of the CPU.

### PSW

#### Program Status Word Register

**Reset Value: 00<sub>H</sub>**

|           |           |           |            |            |           |           |          |
|-----------|-----------|-----------|------------|------------|-----------|-----------|----------|
| 7         | 6         | 5         | 4          | 3          | 2         | 1         | 0        |
| <b>CY</b> | <b>AC</b> | <b>F0</b> | <b>RS1</b> | <b>RS0</b> | <b>OV</b> | <b>F1</b> | <b>P</b> |
| rw        | rwh       | rwh       | rw         | rw         | rwh       | rwh       | rh       |

| Field      | Bits   | Type   | Description  |     |     |          |   |   |  |   |   |  |   |   |  |   |   |  |
|------------|--------|--|--|-----|-----|----------|---|---|--|---|---|--|---|---|--|---|---|--|
| P          | 0      | rh   | <b>Parity Flag</b><br>Set/cleared by hardware after each instruction to indicate an odd/even number of “one” bits in the accumulator, i.e., even parity.   |     |     |          |   |   |  |   |   |  |   |   |  |   |   |  |
| F1         | 1      | rwh  | <b>General Purpose Flag</b>  |     |     |          |   |   |  |   |   |  |   |   |  |   |   |  |
| OV         | 2      | rwh  | <b>Overflow Flag</b><br>Used by arithmetic instructions  |     |     |          |   |   |  |   |   |  |   |   |  |   |   |  |
| RS0<br>RS1 | 3<br>4 | rw   | <b>Register Bank Select</b><br>These bits are used to select one of the four register banks.<br><br><table border="1" style="width: 100%; border-collapse: collapse;"> <thead> <tr> <th>RS1</th> <th>RS0</th> <th>Function</th> </tr> </thead> <tbody> <tr> <td style="text-align: center;">0</td> <td style="text-align: center;">0</td> <td>Bank 0 selected, data address 00<sub>H</sub>-07<sub>H</sub></td> </tr> <tr> <td style="text-align: center;">0</td> <td style="text-align: center;">1</td> <td>Bank 1 selected, data address 08<sub>H</sub>-0F<sub>H</sub></td> </tr> <tr> <td style="text-align: center;">1</td> <td style="text-align: center;">0</td> <td>Bank 2 selected, data address 10<sub>H</sub>-17<sub>H</sub></td> </tr> <tr> <td style="text-align: center;">1</td> <td style="text-align: center;">1</td> <td>Bank 3 selected, data address 18<sub>H</sub>-1F<sub>H</sub></td> </tr> </tbody> </table> | RS1 | RS0 | Function | 0 | 0 | Bank 0 selected, data address 00 <sub>H</sub> -07 <sub>H</sub> | 0 | 1 | Bank 1 selected, data address 08 <sub>H</sub> -0F <sub>H</sub> | 1 | 0 | Bank 2 selected, data address 10 <sub>H</sub> -17 <sub>H</sub> | 1 | 1 | Bank 3 selected, data address 18 <sub>H</sub> -1F <sub>H</sub> |
| RS1        | RS0    | Function   |  |     |     |          |   |   |  |   |   |  |   |   |  |   |   |  |
| 0          | 0      | Bank 0 selected, data address 00 <sub>H</sub> -07 <sub>H</sub> |  |     |     |          |   |   |  |   |   |  |   |   |  |   |   |  |
| 0          | 1      | Bank 1 selected, data address 08 <sub>H</sub> -0F <sub>H</sub> |  |     |     |          |   |   |  |   |   |  |   |   |  |   |   |  |
| 1          | 0      | Bank 2 selected, data address 10 <sub>H</sub> -17 <sub>H</sub> |  |     |     |          |   |   |  |   |   |  |   |   |  |   |   |  |
| 1          | 1      | Bank 3 selected, data address 18 <sub>H</sub> -1F <sub>H</sub> |  |     |     |          |   |   |  |   |   |  |   |   |  |   |   |  |
| F0         | 5      | rwh  | <b>General Purpose Flag</b>  |     |     |          |   |   |  |   |   |  |   |   |  |   |   |  |
| AC         | 6      | rwh  | <b>Auxiliary Carry Flag</b><br>Used by instructions that execute BCD operations  |     |     |          |   |   |  |   |   |  |   |   |  |   |   |  |
| CY         | 7      | rw   | <b>Carry Flag</b><br>Used by arithmetic instructions   |     |     |          |   |   |  |   |   |  |   |   |  |   |   |  |

### 2.1.6 Extended Operation Register (EO)

The EO register has two functions. One function is to select the active data pointer where the derivative has multiple data pointers. The other function is to select the instruction executed on opcode A5<sub>H</sub>. The active instruction is either *TRAP* or *MOVC @(DPTR++),A*.

#### EO

#### Extended Operation Register

Reset Value: 00<sub>H</sub>

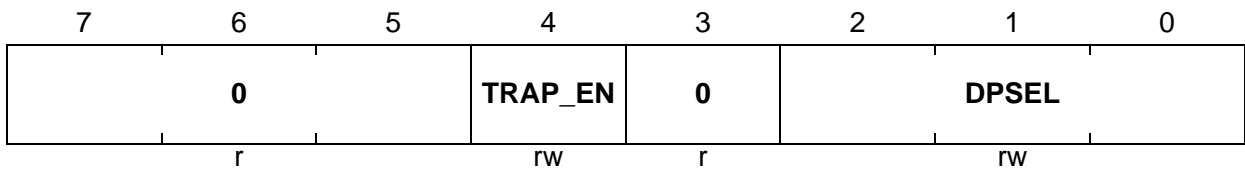

| Field          | Bits     | Type | Description   |
|----------------|----------|------|---|
| <b>DPSEL</b>   | [2:0]    | rw   | <b>Data Pointer Select</b><br>000 DPTR0 selected<br>001 DPTR1 selected (if available)<br>010 DPTR2 selected (if available)<br>011 DPTR3 selected (if available)<br>100 DPTR4 selected (if available)<br>101 DPTR5 selected (if available)<br>110 DPTR6 selected (if available)<br>111 DPTR7 selected (if available) |
| <b>TRAP_EN</b> | 4        | rw   | <b>TRAP Enable</b><br>0 Select <i>MOVC @(DPTR++),A</i><br>1 Select software TRAP instruction  |
| <b>0</b>       | 3, [7:5] | r    | <b>Reserved</b><br>Returns 0 if read; should be written with 0.   |

### 2.1.7 Memory Extension Registers

These registers support the memory extension feature, which may not be available on certain XC800 microcontroller derivatives.

#### MEX1

##### Memory Extension Register 1

Reset Value: 00<sub>H</sub>

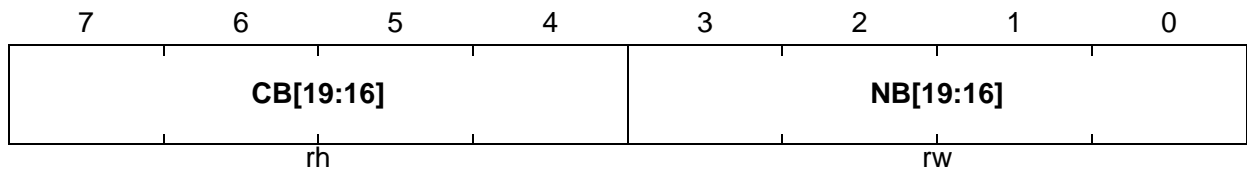

| Field     | Bits  | Type | Description         |
|-----------|-------|------|---------------------|
| NB[19:16] | [3:0] | rw   | Next Bank Number    |
| CB[19:16] | [7:4] | rh   | Current Bank Number |

#### MEX2

##### Memory Extension Register 2

Reset Value: 00<sub>H</sub>

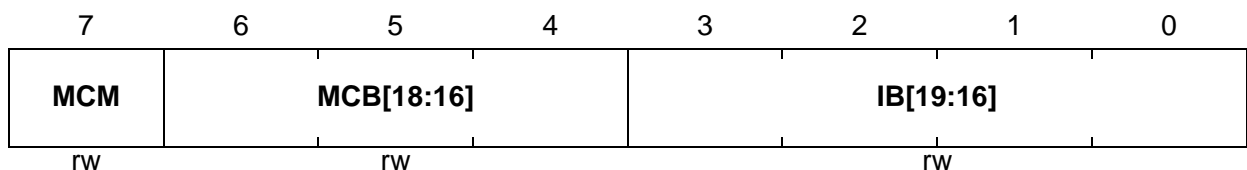

| Field      | Bits  | Type | Description   |
|------------|-------|------|---|
| IB[19:16]  | [3:0] | rw   | Interrupt Bank Number   |
| MCB[18:16] | [6:4] | rw   | Memory Constant Bank Number (with MEX3.7)   |
| MCM        | 7     | rw   | <b>Memory Constant Mode</b><br>0 MOVC access data in the current bank<br>1 MOVC access data in the Memory Constant bank |



**MEX3**
**Memory Extension Register 3**
**Reset Value: 00<sub>H</sub>**

|              |          |   |             |            |                  |   |   |
|--------------|----------|---|-------------|------------|------------------|---|---|
| 7            | 6        | 5 | 4           | 3          | 2                | 1 | 0 |
| <b>MCB19</b> | <b>0</b> |   | <b>MX19</b> | <b>MXM</b> | <b>MX[18:16]</b> |   |   |
| rw           | r        |   | rw          | rw         | rw               |   |   |

| Field            | Bits        | Type | Description   |
|------------------|-------------|------|---|
| <b>MX[19:16]</b> | [2:0],<br>4 | rw   | <b>XRAM Bank Number</b>   |
| <b>MXM</b>       | 3           | rw   | <b>XRAM Bank Selector</b><br>0 MOVX access data in the current bank<br>1 MOVX access data in the Memory XRAM bank |
| <b>MCB19</b>     | 7           | rw   | <b>Memory Constant Bank Number MSB</b>  |
| <b>0</b>         | [6:5]       | r    | <b>Reserved</b><br>Returns 0 if read; should be written with 0.   |

**MEXSP**
**Memory Extension Stack Pointer Register**
**Reset Value: 7F<sub>H</sub>**

|          |             |   |   |   |   |   |   |
|----------|-------------|---|---|---|---|---|---|
| 7        | 6           | 5 | 4 | 3 | 2 | 1 | 0 |
| <b>0</b> | <b>MXSP</b> |   |   |   |   |   |   |
| r        | rw          |   |   |   |   |   |   |

| Field       | Bits  | Type | Description  |
|-------------|-------|------|--|
| <b>MXSP</b> | [6:0] | rw   | <b>Memory Extension Stack Pointer</b><br>It provides for a stack depth of up to 128 bytes. It is pre-incremented by call instructions and post-decremented by return instructions. |
| <b>0</b>    | 7     | r    | <b>Reserved</b><br>Returns 0 if read; should be written with 0.  |

### 2.1.8 Power Control Register (PCON)

The XC800 CPU has two power saving modes: idle mode and power-down mode. In idle mode, the clock to the CPU is disabled while other peripherals may continue to run (possibly at lower frequency). In power-down mode, the clock to the entire CPU is stopped.

#### PCON

#### Power Control Register

Reset Value: 00<sub>H</sub>

|             |   |          |   |            |            |          |             |
|-------------|---|----------|---|------------|------------|----------|-------------|
| 7           | 6 | 5        | 4 | 3          | 2          | 1        | 0           |
| <b>SMOD</b> |   | <b>0</b> |   | <b>GF1</b> | <b>GF0</b> | <b>0</b> | <b>IDLE</b> |
| rw          |   | r        |   | rw         | rw         | r        | rw          |

| Field       | Bits     | Type | Description   |
|-------------|----------|------|---|
| <b>IDLE</b> | 0        | rw   | <b>Idle Mode Enable</b><br>0 Do not enter idle mode<br>1 Enter idle mode  |
| <b>GF0</b>  | 2        | rw   | <b>General Purpose Flag Bit 0</b>   |
| <b>GF1</b>  | 3        | rw   | <b>General Purpose Flag Bit 1</b>   |
| <b>SMOD</b> | 7        | rw   | <b>Double Baud Rate Enable</b><br>0 Do not double the baud rate of serial interface in mode 2<br>1 Double baud rate of serial interface in mode 2 |
| <b>0</b>    | 1, [6:4] | r    | <b>Reserved</b><br>Returns 0 if read; should be written with 0.   |

### 2.1.9 UART Registers

The UART uses two SFRs, SCON and SBUF. SCON is the control register, while SBUF is the data register. The serial port control and status register is the SFR SCON. This register contains not only the mode selection bits, but also the 9th data bit for transmit and receive (TB8 and RB8), and the serial port interrupt bits (TI and RI).

SBUF is the receive and transmit buffer of the serial interface. Writing to SBUF loads the transmit register and initiates transmission. SBUF is read to access the received data from the receive register. The two paths are independent and supports full duplex operation.

#### SBUF

##### Serial Data Buffer

Reset Value: 00<sub>H</sub>

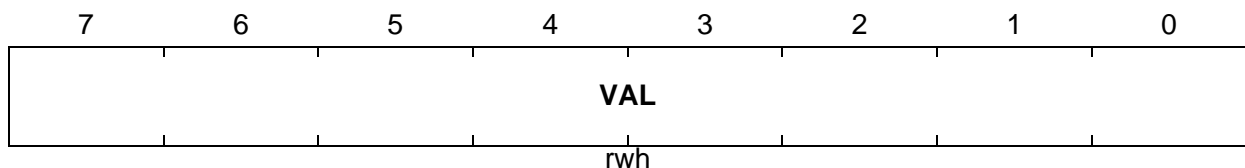

| Field | Bits  | Type | Description                      |
|-------|-------|------|----------------------------------|
| VAL   | [7:0] | rwh  | Serial Interface Buffer Register |

#### SCON

##### Serial Channel Control Register

Reset Value: 00<sub>H</sub>

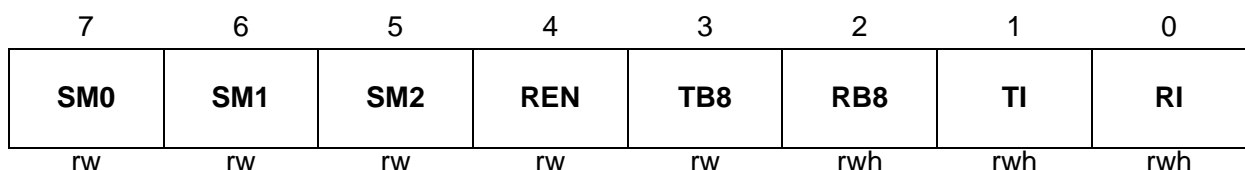

| Field | Bits | Type | Description   |
|-------|------|------|---|
| RI    | 0    | rwh  | <b>Receive Interrupt Flag</b><br>This is set by hardware at the end of the 8th bit in mode 0, or at the half point of the stop bit in modes 1, 2, and 3. Must be cleared by software. |
| TI    | 1    | rwh  | <b>Transmit Interrupt Flag</b><br>This is set by hardware at the end of the 8th bit in mode 0, or at the beginning of the stop bit in modes 1, 2, and 3. Must be cleared by software. |

CPU Architecture

| Field      | Bits   | Type   | Description   |     |     |                         |   |   |  |   |   |  |   |   |  |   |   |  |
|------------|--------|--|---|-----|-----|-------------------------|---|---|--|---|---|--|---|---|--|---|---|--|
| RB8        | 2      | rwh  | <b>Serial Port Receiver Bit 9</b><br>In modes 2 and 3, this is the 9th data bit received.<br>In mode 1, if SM2 = 0, this is the stop bit received.<br>In mode 0, RB8 is not used.   |     |     |                         |   |   |  |   |   |  |   |   |  |   |   |  |
| TB8        | 3      | rw   | <b>Serial Port Transmitter Bit 9</b><br>In modes 2 and 3, this is the 9th data bit sent.  |     |     |                         |   |   |  |   |   |  |   |   |  |   |   |  |
| REN        | 4      | rw   | <b>Enable Receiver of Serial Port</b><br>0 Serial reception is disabled<br>1 Serial reception is enabled  |     |     |                         |   |   |  |   |   |  |   |   |  |   |   |  |
| SM2        | 5      | rw   | <b>Enable Serial Port Multiprocessor Communication in Modes 2 and 3</b><br>In mode 2 or 3, if SM2 is set to 1, RI will not be activated if the received 9th data bit (RB8) is 0.<br>In mode 1, if SM2 is set to 1, RI will not be activated if a valid stop bit (RB8) was not received.<br>In mode 0, SM2 should be set to 0.   |     |     |                         |   |   |  |   |   |  |   |   |  |   |   |  |
| SM1<br>SM0 | 6<br>7 | rw   | <p><b>Serial Port Operating Mode Selection</b></p> <table border="1"> <thead> <tr> <th>SM0</th> <th>SM1</th> <th>Selected operating mode</th> </tr> </thead> <tbody> <tr> <td>0</td> <td>0</td> <td>Mode 0: 8-bit shift register, fixed baud rate = <math>f_{PCLK}/2</math></td> </tr> <tr> <td>0</td> <td>1</td> <td>Mode 1: 8-bit UART, variable baud rate</td> </tr> <tr> <td>1</td> <td>0</td> <td>Mode 2: 9-bit UART, fixed baud rate (<math>f_{PCLK}/32</math> or <math>f_{PCLK}/64</math>)</td> </tr> <tr> <td>1</td> <td>1</td> <td>Mode 3: 9-bit UART, variable baud rate</td> </tr> </tbody> </table> | SM0 | SM1 | Selected operating mode | 0 | 0 | Mode 0: 8-bit shift register, fixed baud rate = $f_{PCLK}/2$ | 0 | 1 | Mode 1: 8-bit UART, variable baud rate | 1 | 0 | Mode 2: 9-bit UART, fixed baud rate ( $f_{PCLK}/32$ or $f_{PCLK}/64$ ) | 1 | 1 | Mode 3: 9-bit UART, variable baud rate |
| SM0        | SM1    | Selected operating mode  |   |     |     |                         |   |   |  |   |   |  |   |   |  |   |   |  |
| 0          | 0      | Mode 0: 8-bit shift register, fixed baud rate = $f_{PCLK}/2$           |   |     |     |                         |   |   |  |   |   |  |   |   |  |   |   |  |
| 0          | 1      | Mode 1: 8-bit UART, variable baud rate                                 |   |     |     |                         |   |   |  |   |   |  |   |   |  |   |   |  |
| 1          | 0      | Mode 2: 9-bit UART, fixed baud rate ( $f_{PCLK}/32$ or $f_{PCLK}/64$ ) |   |     |     |                         |   |   |  |   |   |  |   |   |  |   |   |  |
| 1          | 1      | Mode 3: 9-bit UART, variable baud rate                                 |   |     |     |                         |   |   |  |   |   |  |   |   |  |   |   |  |

### 2.1.10 Timer/Counter Registers

Two 16-bit timers, Timer 0 and Timer 1, are available in the XC800 core.

The SFR TCON controls the running of the timers and generating of interrupts, while SFR TMOD sets the operating modes of the timers. The timer/counter values are stored in two pairs of 8-bit registers: TL0, TH0 and TL1, TH1.

#### TCON

#### Timer Control Register

Reset Value: 00<sub>H</sub>

|            |            |            |            |            |            |            |            |
|------------|------------|------------|------------|------------|------------|------------|------------|
| 7          | 6          | 5          | 4          | 3          | 2          | 1          | 0          |
| <b>TF1</b> | <b>TR1</b> | <b>TF0</b> | <b>TR0</b> | <b>IE1</b> | <b>IT1</b> | <b>IE0</b> | <b>IT0</b> |
| rwh        | rw         | rwh        | rw         | rw         | rw         | rw         | rw         |



The functions of the shaded bits are not described here

| Field | Bits | Type | Description   |
|-------|------|------|---|
| TR0   | 4    | rw   | <b>Timer 0 Run Control</b><br>0 Timer is halted<br>1 Timer runs   |
| TF0   | 5    | rwh  | <b>Timer 0 Overflow Flag</b><br>Set by hardware when Timer 0 overflows. Cleared by hardware when the processor calls the interrupt service routine.               |
| TR1   | 6    | rw   | <b>Timer 1 Run Control<sup>1)</sup></b><br>0 Timer is halted<br>1 Timer runs  |
| TF1   | 7    | rwh  | <b>Timer 1 Overflow Flag</b><br>Set by hardware when Timer 1 <sup>2)</sup> overflows. Cleared by hardware when the processor calls the interrupt service routine. |

1) Also affects TH0 if Timer 0 operates in mode 3.

2) TF1 is set by TH0 instead if Timer 0 operates in mode 3.

**TMOD**

**Timer Mode Register**

Reset Value: 00<sub>H</sub>

|  |              |            |            |   |              |            |            |   |
|--|--------------|------------|------------|---|--------------|------------|------------|---|
|  | 7            | 6          | 5          | 4 | 3            | 2          | 1          | 0 |
|  | <b>GATE1</b> | <b>CT1</b> | <b>T1M</b> |   | <b>GATE0</b> | <b>CT0</b> | <b>T0M</b> |   |
|  | rw           | rw         | rw         |   | rw           | rw         | rw         |   |

| Field                 | Bits  | Type | Description  |               |          |    |   |    |  |    |  |    |   |
|-----------------------|---|------|--|---------------|----------|----|---|----|--|----|--|----|---|
| T0M[1:0],<br>T1M[1:0] | [1:0],<br>[5:4]   | rw   | <p><b>Mode select bits</b></p> <table border="1" style="width:100%; border-collapse: collapse;"> <thead> <tr> <th style="width:20%;">T0M/T1M [1:0]</th> <th style="width:80%;">Function</th> </tr> </thead> <tbody> <tr> <td>00</td> <td>13-bit timer<br/>THx operates as 8-bit timer/counter<br/>TLx is a 5-bit prescaler</td> </tr> <tr> <td>01</td> <td>16-bit timer<br/>THx and TLx are cascaded</td> </tr> <tr> <td>10</td> <td>8-bit auto-reload timer<br/>THx holds the reload value which is reloaded into TLx each time it overflow</td> </tr> <tr> <td>11</td> <td>Timer 0:<br/>Timer 0 is divided into two parts. TL0 is an 8-bit timer controlled by the standard Timer 0 control bits, and TH0 is the other 8-bit timer controlled by the standard Timer 1 control bits.<br/>Timer 1:<br/>TH1 and TL1 are held (Timer 1 is stopped).</td> </tr> </tbody> </table> | T0M/T1M [1:0] | Function | 00 | 13-bit timer<br>THx operates as 8-bit timer/counter<br>TLx is a 5-bit prescaler | 01 | 16-bit timer<br>THx and TLx are cascaded | 10 | 8-bit auto-reload timer<br>THx holds the reload value which is reloaded into TLx each time it overflow | 11 | Timer 0:<br>Timer 0 is divided into two parts. TL0 is an 8-bit timer controlled by the standard Timer 0 control bits, and TH0 is the other 8-bit timer controlled by the standard Timer 1 control bits.<br>Timer 1:<br>TH1 and TL1 are held (Timer 1 is stopped). |
| T0M/T1M [1:0]         | Function  |      |  |               |          |    |   |    |  |    |  |    |   |
| 00                    | 13-bit timer<br>THx operates as 8-bit timer/counter<br>TLx is a 5-bit prescaler   |      |  |               |          |    |   |    |  |    |  |    |   |
| 01                    | 16-bit timer<br>THx and TLx are cascaded  |      |  |               |          |    |   |    |  |    |  |    |   |
| 10                    | 8-bit auto-reload timer<br>THx holds the reload value which is reloaded into TLx each time it overflow  |      |  |               |          |    |   |    |  |    |  |    |   |
| 11                    | Timer 0:<br>Timer 0 is divided into two parts. TL0 is an 8-bit timer controlled by the standard Timer 0 control bits, and TH0 is the other 8-bit timer controlled by the standard Timer 1 control bits.<br>Timer 1:<br>TH1 and TL1 are held (Timer 1 is stopped). |      |  |               |          |    |   |    |  |    |  |    |   |
| CT0,<br>CT1           | 2,<br>6   | rw   | <p><b>Counter Selection for Timer x</b></p> <p>0 Timer mode (input from internal system clock)</p> <p>1 Counter mode (input from Tx input pin)</p>   |               |          |    |   |    |  |    |  |    |   |
| GATE0,<br>GATE1       | 3,<br>7   | rw   | <p><b>Timer x Gating Control</b></p> <p>0 Timer x will only run if TCON.TRx = 1 (software control)</p> <p>1 Timer x will only run if NINTx pin = 0 (hardware control) and TCON.TRx is set</p>  |               |          |    |   |    |  |    |  |    |   |

### 2.1.11 Interrupt Registers

Each interrupt for a peripheral (if available for the derivative) can be individually enabled or disabled by setting or clearing the corresponding bit in the bitaddressable interrupt enable registers IEN0 and IEN1. Register IEN0 also contains the global enable/disable bit (EA), which can be cleared to disable all interrupts at once. The Non-Maskable Interrupt (NMI) is always enabled.

After reset, the enable bits of IEN0 and IEN1 are cleared to 0. This implies that the corresponding interrupts are disabled.

#### IEN0

#### Interrupt Enable Register 0

Reset Value: 00<sub>H</sub>

|           |          |            |           |            |            |            |            |
|-----------|----------|------------|-----------|------------|------------|------------|------------|
| 7         | 6        | 5          | 4         | 3          | 2          | 1          | 0          |
| <b>EA</b> | <b>0</b> | <b>ET2</b> | <b>ES</b> | <b>ET1</b> | <b>EX1</b> | <b>ET0</b> | <b>EX0</b> |
| rw        | r        | rw         | rw        | rw         | rw         | rw         | rw         |

| Field      | Bits | Type | Description   |
|------------|------|------|---|
| <b>EX0</b> | 0    | rw   | <b>Enable External Interrupt 0</b><br>0 External Interrupt 0 is disabled.<br>1 External Interrupt 0 is enabled.                   |
| <b>ET0</b> | 1    | rw   | <b>Enable Timer 0 Overflow Interrupt</b><br>0 Timer 0 Overflow interrupt is disabled.<br>1 Timer 0 Overflow interrupt is enabled. |
| <b>EX1</b> | 2    | rw   | <b>Enable External Interrupt 1</b><br>0 External interrupt 1 is disabled.<br>1 External interrupt 1 is enabled.                   |
| <b>ET1</b> | 3    | rw   | <b>Enable Timer 1 Overflow Interrupt</b><br>0 Timer 1 Overflow interrupt is disabled.<br>1 Timer 1 Overflow interrupt is enabled. |
| <b>ES</b>  | 4    | rw   | <b>Enable Serial Port Interrupt</b><br>0 Serial Port interrupt is disabled.<br>1 Serial Port interrupt is enabled.                |
| <b>ET2</b> | 5    | rw   | <b>Enable Timer 2 Interrupt</b><br>0 Timer 2 interrupt is disabled.<br>1 Timer 2 interrupt is enabled.                            |

**CPU Architecture**

| Field     | Bits | Type | Description  |
|-----------|------|------|--|
| <b>EA</b> | 7    | rw   | <b>Enable/disable All Interrupts</b><br>0 No interrupt will be acknowledged.<br>1 Each interrupt source is individually enabled or disabled by setting or clearing its enable bit. |
| <b>0</b>  | 6    | r    | <b>Reserved</b><br>Returns 0 if read; should be written with 0.  |

The interrupt enable bits of IEN1 are used to enable or disable the corresponding interrupts. The assignment of these bits depends on which peripheral set is available on the derivative.

**IEN1**
**Interrupt Enable Register 1**
**Reset Value: 00<sub>H</sub>**

|             |             |             |             |            |            |            |            |
|-------------|-------------|-------------|-------------|------------|------------|------------|------------|
| 7           | 6           | 5           | 4           | 3          | 2          | 1          | 0          |
| <b>EI13</b> | <b>EI12</b> | <b>EI11</b> | <b>EI10</b> | <b>EI9</b> | <b>EI8</b> | <b>EI7</b> | <b>EI6</b> |
| rw          | rw          | rw          | rw          | rw         | rw         | rw         | rw         |

| Field                   | Bits  | Type | Description   |
|-------------------------|-------|------|---|
| <b>EIx (x = 6 - 13)</b> | [7:0] | rw   | <b>Extended Interrupt Enable</b><br>0 Interrupt is disabled.<br>1 Interrupt is enabled. |

Each interrupt source can be individually programmed to one of the four priority levels available via the corresponding IP, IPH or IP1, IPH1 registers. IP and IP1 are bitaddressable, but not IPH and IPH1.

**IP**
**Interrupt Priority Register**
**Reset Value: 00<sub>H</sub>**

|          |            |           |            |            |            |            |    |
|----------|------------|-----------|------------|------------|------------|------------|----|
| 7        | 6          | 5         | 4          | 3          | 2          | 1          | 0  |
| <b>0</b> | <b>PT2</b> | <b>PS</b> | <b>PT1</b> | <b>PX1</b> | <b>PT0</b> | <b>PX0</b> |    |
| r        | rw         | rw        | rw         | rw         | rw         | rw         | rw |



**IPH**

**Interrupt Priority High Register**

Reset Value: **XX00 0000<sub>B</sub>**

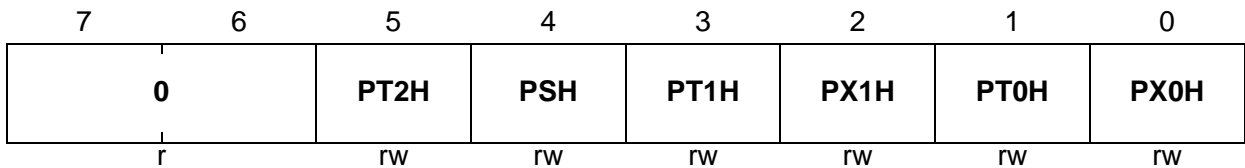

| Field            | Bits  | Type | Description   |
|------------------|-------|------|---|
| <b>PX0, PX0H</b> | 0     | rw   | <b>Priority Level for External Interrupt 0</b>                  |
| <b>PT0, PT0H</b> | 1     | rw   | <b>Priority Level for Timer 0 Overflow Interrupt</b>            |
| <b>PX1, PX1H</b> | 2     | rw   | <b>Priority Level for External Interrupt 1</b>                  |
| <b>PT1, PT1H</b> | 3     | rw   | <b>Priority Level for Timer 1 Overflow Interrupt</b>            |
| <b>PS, PSH</b>   | 4     | rw   | <b>Priority Level for Serial Port Interrupt</b>                 |
| <b>PT2, PT2H</b> | 5     | rw   | <b>Priority Level for Timer 2 Interrupt</b>                     |
| <b>0</b>         | [7:6] | r    | <b>Reserved</b><br>Returns 0 if read; should be written with 0. |

The respective bit fields of the interrupt priority registers together select one of the four levels of priority shown in [Table 2-1](#).

**Table 2-1 Interrupt Priority Level Selection**

| IPH.x / IPH1.x | IP.x / IP1.x | Priority Level    |
|----------------|--------------|-------------------|
| 0              | 0            | Level 0 (lowest)  |
| 0              | 1            | Level 1           |
| 1              | 0            | Level 2           |
| 1              | 1            | Level 3 (highest) |

*Note: The NMI always takes precedence over all other interrupts.*

Four bits are available in TCON to control and flag the external interrupts.

**TCON**

**Timer Control Register**

Reset Value: 00<sub>H</sub>

|            |            |            |            |            |            |            |            |
|------------|------------|------------|------------|------------|------------|------------|------------|
| 7          | 6          | 5          | 4          | 3          | 2          | 1          | 0          |
| <b>TF1</b> | <b>TR1</b> | <b>TF0</b> | <b>TR0</b> | <b>IE1</b> | <b>IT1</b> | <b>IE0</b> | <b>IT0</b> |
| rwh        | rw         | rwh        | rw         | rwh        | rw         | rwh        | rw         |



The functions of the shaded bits are not described here

| Field      | Bits | Type | Description  |
|------------|------|------|--|
| <b>IT0</b> | 0    | rw   | <b>External Interrupt 0 Level/Edge Trigger Control Flag</b><br>0 Low level triggered external interrupt 0 is selected.<br>1 Falling edge triggered external interrupt 0 is selected. |
| <b>IE0</b> | 1    | rwh  | <b>External Interrupt 0 Request Flag</b><br>Set by hardware when external interrupt 0 edge is detected.<br>Cleared by hardware when the processor vectors to interrupt routine.      |
| <b>IT1</b> | 2    | rw   | <b>External Interrupt 1 Level/Edge Trigger Control Flag</b><br>0 Low level triggered external interrupt 1 is selected.<br>1 Falling edge triggered external interrupt 1 is selected. |
| <b>IE1</b> | 3    | rwh  | <b>External Interrupt 1 Request Flag</b><br>Set by hardware when external interrupt 1 edge is detected.<br>Cleared by hardware when the processor vectors to interrupt routine.      |

## 2.2 On-Chip Debug Support Concept

The XC800 microcontrollers have an On-Chip Debug Support (OCDS) unit that provides basic functionality to support software development and debugging of the XC800-based systems. The debug functionality is usually enabled after the device has been started in OCDS mode.

The debug concept is based on the interaction between the OCDS hardware and a dedicated software (Monitor program) which is usually located in the Boot ROM. Standard interface such as the JTAG or UART is used to communicate with an external host (a debugger).

An overview of the debug interfaces is shown in **Figure 2-3**.

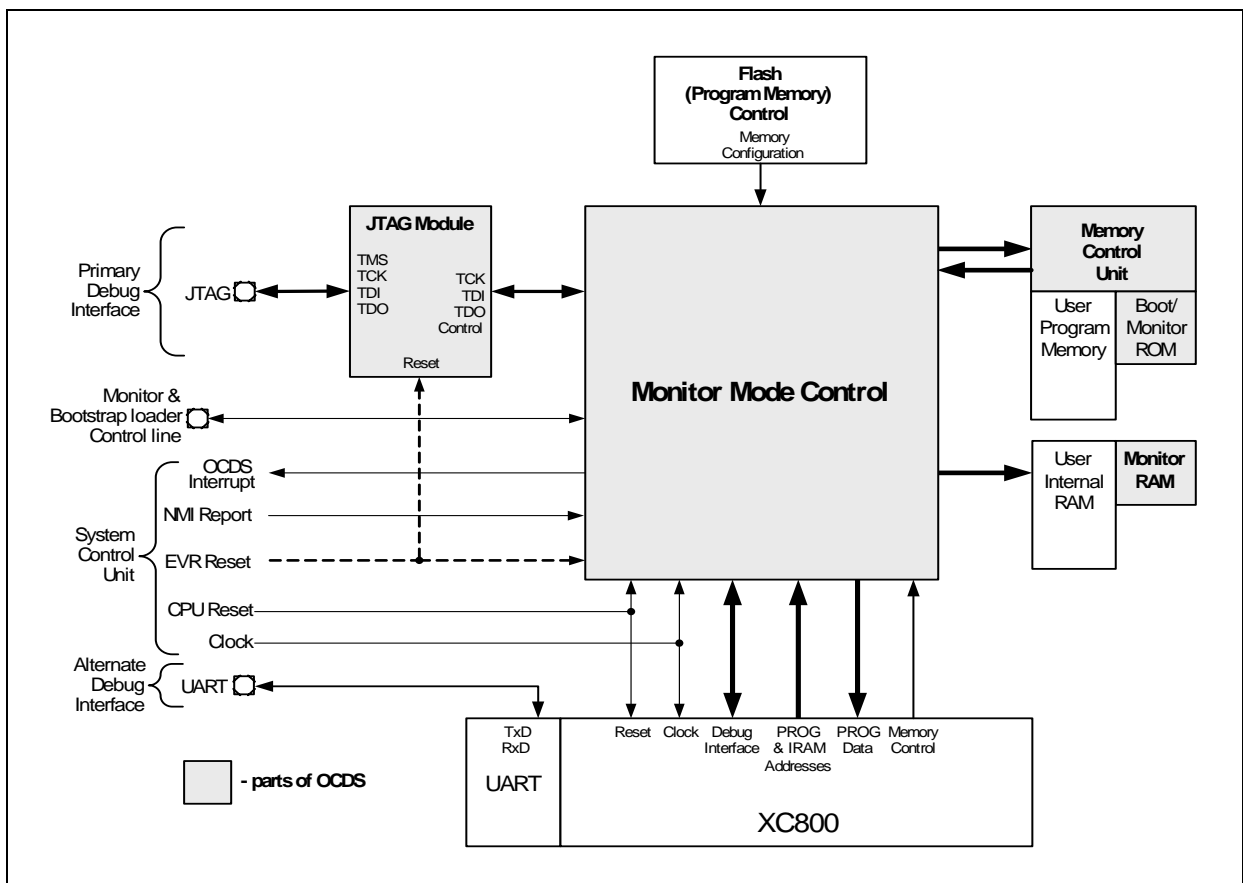

**Figure 2-3 XC800 OCDS Block Diagram**

- A Monitor Mode Control (MMC) block at the center of the OCDS system brings together control signals and supports the overall functionality
- MMC communicates with the XC800 core primarily via the Debug Interface, and also receives reset and clock signals
- After processing memory address and control signals from the core, MMC provides proper access to the dedicated memories: a Monitor ROM (holding the code) and a Monitor RAM (for work-data and Monitor-stack)

- Two interfaces can be used to access the OCDS system:
  - JTAG as a primary channel; dedicated exclusively to test and debug activities and is not normally used in an application
  - UART as an alternative channel; it has the advantage of needing fewer pins, but causes a loss (at least partially) to the standard serial interface while debugging
- A dedicated pin is used as external configuration and control for both the debugging and bootstrap-loading.

The on-chip debug concept is based on the generation and detection of debug events and the corresponding debug actions.

- Debug events:
  - Hardware Breakpoints
  - Software Breakpoints
  - External Breaks
- Debug event actions (non-exclusive):
  - Call the Monitor Program: once in debug mode and with the Monitor running, access for read and write of all of the (non-protected) system resources and data can be communicated through an external debugger.
  - Activate the MBC pin

## 2.3 Basic Interrupt Handling

### 2.3.1 Interrupt Source and Vector Address

Each interrupt source has an associated interrupt vector address. This vector is accessed to service the corresponding interrupt source. The assignment of the XC800 interrupt sources is summarized in [Table 2-2](#). The extended interrupts are generally assigned to on-chip peripherals, which vary depending on the XC800 derivative.

**Table 2-2 Interrupt Vector Addresses**

| <b>Interrupt Source</b> | <b>Vector Address</b> | <b>Interrupt Sources</b>       |
|-------------------------|-----------------------|--------------------------------|
| XINTR0                  | 0003 <sub>H</sub>     | External Interrupt 0           |
| XINTR1                  | 000B <sub>H</sub>     | Timer 0                        |
| XINTR2                  | 0013 <sub>H</sub>     | External Interrupt 1           |
| XINTR3                  | 001B <sub>H</sub>     | Timer 1                        |
| XINTR4                  | 0023 <sub>H</sub>     | UART                           |
| XINTR5                  | 002B <sub>H</sub>     | Extended Interrupt 5 (Timer 2) |
| XINTR6                  | 0033 <sub>H</sub>     | Extended Interrupt 6           |
| XINTR7                  | 003B <sub>H</sub>     | Extended Interrupt 7           |
| XINTR8                  | 0043 <sub>H</sub>     | Extended Interrupt 8           |
| XINTR9                  | 004B <sub>H</sub>     | Extended Interrupt 9           |
| XINTR10                 | 0053 <sub>H</sub>     | Extended Interrupt 10          |
| XINTR11                 | 005B <sub>H</sub>     | Extended Interrupt 11          |
| XINTR12                 | 0063 <sub>H</sub>     | Extended Interrupt 12          |
| XINTR13                 | 006B <sub>H</sub>     | Extended Interrupt 13          |
| NMI                     | 0073 <sub>H</sub>     | Non-maskable Interrupt         |

### 2.3.2 Interrupt Handling

The interrupt flags are sampled at phase 2 in each machine cycle. The sampled flags are polled during the following machine cycle. If one of the flags was in a set condition at phase 2 of the preceding cycle, the polling cycle will find it and the interrupt system will generate a LCALL to the appropriate service routine, provided this hardware-generated LCALL is not blocked by any of the following conditions:

1. An interrupt of equal or higher priority is already in progress.
2. The current (polling) cycle is not in the final cycle of the instruction in progress.

3. The instruction in progress is RETI or any write access to registers IEN0/IEN1 or IP,IPH/IP1,IP1H.

Any of these three conditions will block the generation of the LCALL to the interrupt service routine. Condition 2 ensures that the instruction in progress is completed before vectoring to any service routine. Condition 3 ensures that if the instruction in progress is RETI or any write access to registers IEN0/IEN1 or IP,IPH/IP1,IP1H, then at least one more instruction will be executed before any interrupt is vectored to; this delay guarantees that changes in the interrupt status can be observed by the CPU.

The polling cycle is repeated with each machine cycle, and the values polled are the values that were present at phase 2 of the previous machine cycle. Note that if any interrupt flag is active but not responded to for one of the conditions already mentioned, or if the flag is no longer active when the blocking condition is removed, the denied interrupt will not be serviced. In other words, the fact that the interrupt flag was once active but not serviced is not remembered. Every polling cycle interrogates only the pending interrupt requests.

The processor acknowledges an interrupt request by executing a hardware generated LCALL to the appropriate servicing routine. In some cases, hardware also clears the flag that generated the interrupt, while in other cases, the flag must be cleared by the user's software. The hardware-generated LCALL pushes the contents of the program counter onto the stack (but it does not save the PSW) and reloads the program counter with an address that depends on the source of the interrupt being vectored to.

Execution proceeds from that location until the RETI instruction is encountered. The RETI instruction informs the processor that the interrupt routine is no longer in progress, then pops the two top bytes from the stack and reloads the program counter. Execution of the interrupted program continues from the point where it was stopped. Note that the RETI instruction is important because it informs the processor that the program has left the current interrupt priority level. A simple RET instruction would also have returned execution to the interrupted program; but, it would have left the interrupt control system on the assumption that an interrupt was still in progress. In this case, no interrupt of the same or lower priority level would be acknowledged.

## 2.4 Interrupt Response Time

If an external interrupt is recognized, its corresponding request flag is set at phase 2 in every machine cycle. The value is not polled by the circuitry until the next machine cycle. If the request is active and conditions are right for it to be acknowledged, a hardware subroutine call to the requested service routine will be the next instruction to be executed. The call itself takes two machine cycles. Thus, a minimum of three complete machine cycles will elapse between activation of the interrupt request and the beginning of execution of the first instruction of the service routine. A longer response time would be obtained if the request is blocked by one of the three previously listed conditions. If an interrupt of equal or higher priority is already in progress, the additional wait time will

depend on the nature of the other interrupt's service routine. If the instruction in progress is not in its final cycle, the additional wait time cannot be more than three machine cycles since the longest instructions (MUL and DIV) are only four machine cycles long. If the instruction in progress is RETI or a write access to registers IEN0, IEN1 or IP(H), IP1(H), the additional wait time cannot be more than five cycles (a maximum of one more machine cycle to complete the instruction in progress, plus four machine cycles to complete the next instruction, if the instruction is MUL or DIV). Thus, in a single interrupt system without wait states, the response time is between three and nine machine cycles.

## 2.5 Service Order

A low-priority interrupt can be interrupted by a high-priority interrupt, but not by another interrupt of the same or lower priority. An interrupt of the highest priority cannot be interrupted by any other interrupt source.

If two or more requests of different priority levels are received simultaneously, the request of the highest priority is serviced first. If requests of the same priority are received simultaneously, an internal polling sequence determines which request is serviced first. Thus, within each priority level there is a second priority structure determined by the polling sequence as shown in [Table 2-3](#). The extended interrupts that are applicable, vary depending on the XC800 derivative.

**Table 2-3 Priority Structure within Interrupt Level**

| Source                         | Level     |
|--------------------------------|-----------|
| Non-maskable Interrupt (NMI)   | (highest) |
| External Interrupt 0           | 1         |
| Timer 0 Interrupt              | 2         |
| External Interrupt 1           | 3         |
| Timer 1 Interrupt              | 4         |
| UART Interrupt                 | 5         |
| Extended Interrupt 5 (Timer 2) | 6         |
| Extended Interrupt 6           | 7         |
| Extended Interrupt 7           | 8         |
| Extended Interrupt 8           | 9         |
| Extended Interrupt 9           | 10        |
| Extended Interrupt 10          | 11        |
| Extended Interrupt 11          | 12        |

**Table 2-3 Priority Structure within Interrupt Level (cont'd)**

| <b>Source</b>         | <b>Level</b> |
|-----------------------|--------------|
| Extended Interrupt 12 | 13           |
| Extended Interrupt 13 | 14           |



### 3 CPU Timing

#### 3.1 Instruction Timing

A CPU machine cycle comprises two input clock periods, referred to as Phase 1 (P1) and Phase 2 (P2), that correspond to two different CPU states. A CPU state within an instruction is referenced by the machine cycle and state number, e.g., C2P1 means the first clock period within machine cycle 2. Memory access takes place during one or both phases of the machine cycle. SFR writes occur only at the end of P2. Instructions are 1, 2, or 3 bytes long and can take 1, 2 or 4 machine cycles to execute. Registers are generally updated and the next opcode pre-fetched at the end of P2 of the last machine cycle for the current instruction.

The XC800 core supports access to slow (internal) memory by using wait state(s). Each wait state lasts one machine cycle. For example, in case of a memory requiring one wait state, the access time is increased by one machine cycle after every byte of opcode/operand fetched.

**Figure 3-1** shows the fetch/execute timing related to the internal states and phases. Execution of an instruction occurs at C1P1. For a 2-byte instruction, the second reading starts at C1P1.

**Figure 3-1** (a) shows two timing diagrams for a 1-byte, 1-cycle (1 · machine cycle) instruction. The first diagram shows the instruction being executed within one machine cycle since the opcode (C1P2) is fetched from a memory without wait state. The second diagram shows the corresponding states of the same instruction being executed over two machine cycles (instruction time extended), with one wait state inserted for opcode fetching from a slower memory.

**Figure 3-1** (b) shows two timing diagrams for a 2-byte, 1-cycle (1 · machine cycle) instruction. The first diagram shows the instruction being executed within one machine cycle since the second byte (C1P1) and the opcode (C1P2) are fetched from a memory without wait state. The second diagram shows the corresponding states of the same instruction being executed over three machine cycles (instruction time extended), with one wait state inserted for each access to the slow memory (two wait states inserted in total).

**Figure 3-1** (c) shows two timing diagrams of a 1-byte, 2-cycle (2 · machine cycle) instruction. The first diagram shows the instruction being executed over two machine cycles with the opcode (C2P2) fetched from a memory without wait state. The second diagram shows the corresponding states of the same instruction being executed over three machine cycles (instruction time extended), with one wait state inserted for opcode fetching from the slow memory.

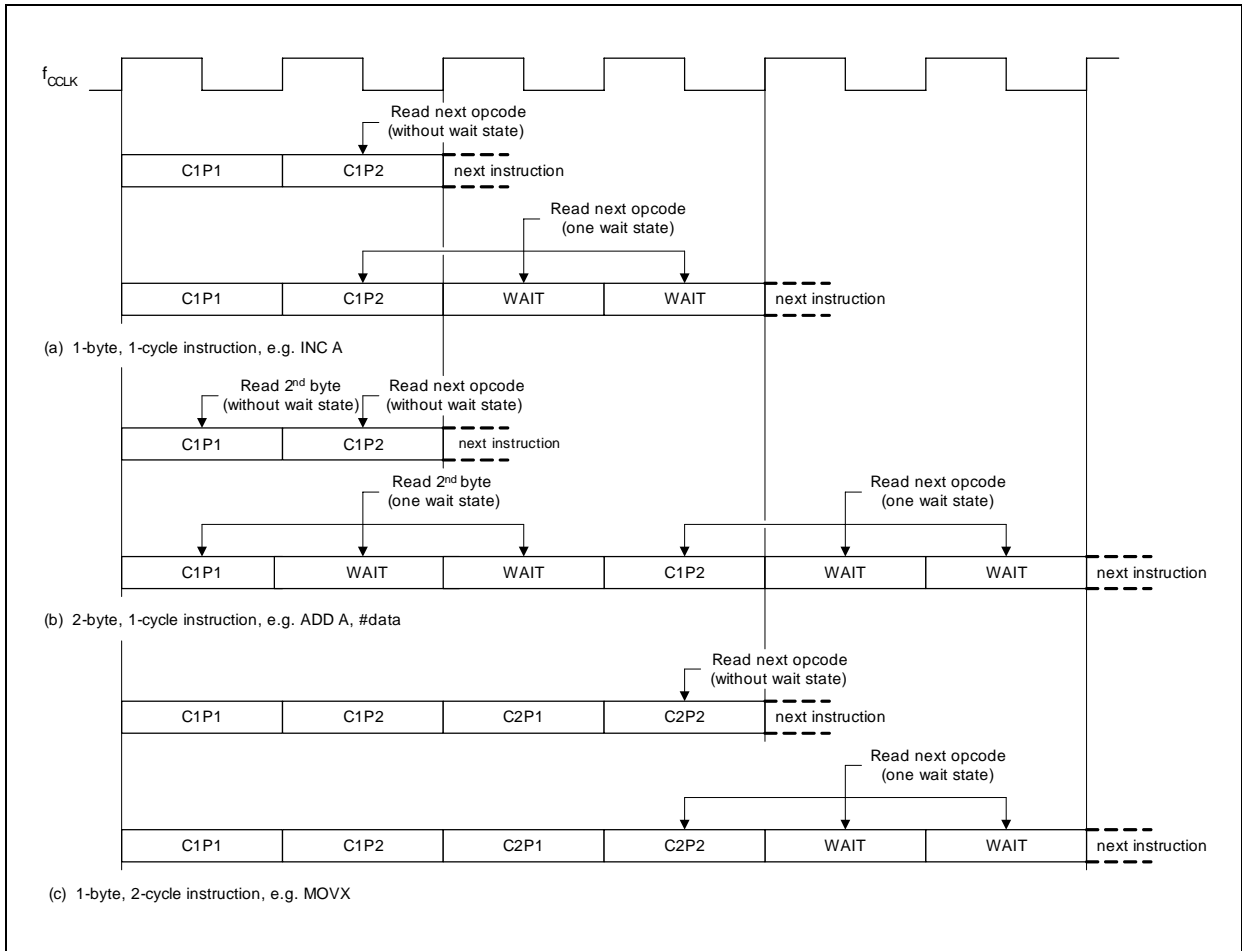

**Figure 3-1 CPU Instruction Timing**

The time taken for each instruction includes:

- decoding/executing the fetched opcode
- fetching the operand/s (for instructions > 1 byte)
- fetching the first byte (opcode) of the next instruction (due to CPU pipeline)

*Note: The XC800 CPU fetches the opcode of the next instruction while executing the current instruction.*

Even with one wait state inserted for each byte of operand/opcode fetched, the XC800 CPU executes instructions faster than the standard 8051 processor by a factor of between two (e.g., 2-byte, 1-cycle instructions) to six (e.g., 1-byte, 4-cycle instructions).

### 3.2 Accessing External Memory

There are two types of external memory accesses: accesses to external program memory and accesses to external data memory. Accesses to external program memory use the signal PSEN as the read strobe, while accesses to external data memory use the RD or WR to read or write the memory. Depending on the derivative that supports external memory accessing, address (Ax) and data (D[7:0]) lines may be multiplexed as alternate function of the available ports.

#### 3.2.1 Accessing External Program Memory

External program memory is generally accessed under two conditions:

- Whenever  $\overline{EA}$  is active (low), or
- Whenever  $\overline{EA}$  is inactive (high) and the program counter (PC) contains an address outside the range of the internal code memories.

Fetches from external program memory use address bus width of 16 bits, and up to 20 bits if memory extension is supported (uppermost 4 bits for bank selection). These address pins are the alternate function of the corresponding ports, and when the CPU is executing from external program memory, should never be used for other alternate port functions.

Figure 3-2 shows the timing of the external program memory access cycle.

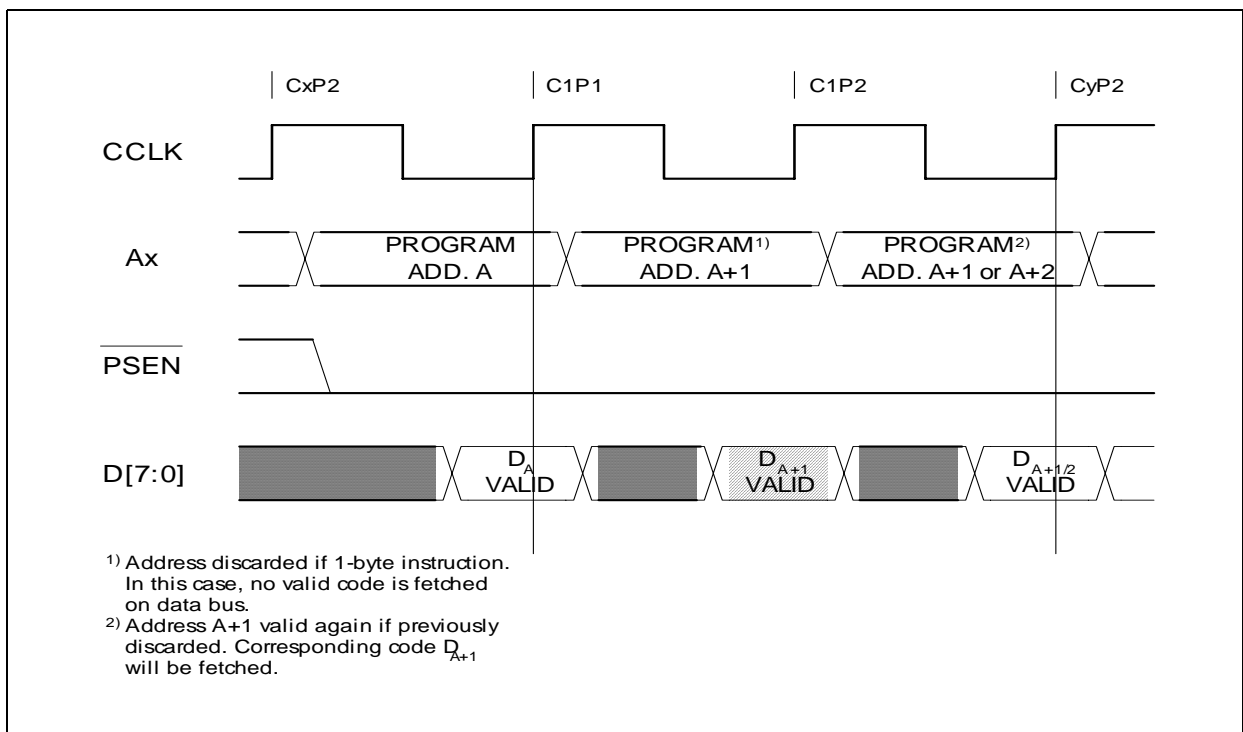

Figure 3-2 External Program Memory Fetches

### 3.2.2 Accessing External Data Memory

External data memory may generally be accessed only if the corresponding address is not occupied by internal program memory in the code space.

The access to external data memory uses address bits 17 up to 20 (if available) for bank selection. Within each bank of external data memory, access can be via either a 16-bit address (*MOVX @DPTR*) or an 8-bit address (*MOVX @R<sub>i</sub>*). If an 8-bit addressing mode is used, any output port pins can be used to output high-order address bits. Alternatively, the contents of the corresponding port SFR of the high-byte address pins may be initialised to hold the high-byte address on the pins during the external memory access. These pins are therefore used to page the current active bank (selected by MEX1.CBx or MEX3.MXx) of external memory by defining the upper address byte.

In a read cycle, the incoming byte is accepted just before the read strobe  $\overline{RD}$  is deactivated.

**Figure 3-3** shows the timing of the external data memory read cycle. This timing assumes only data access on the external interface.

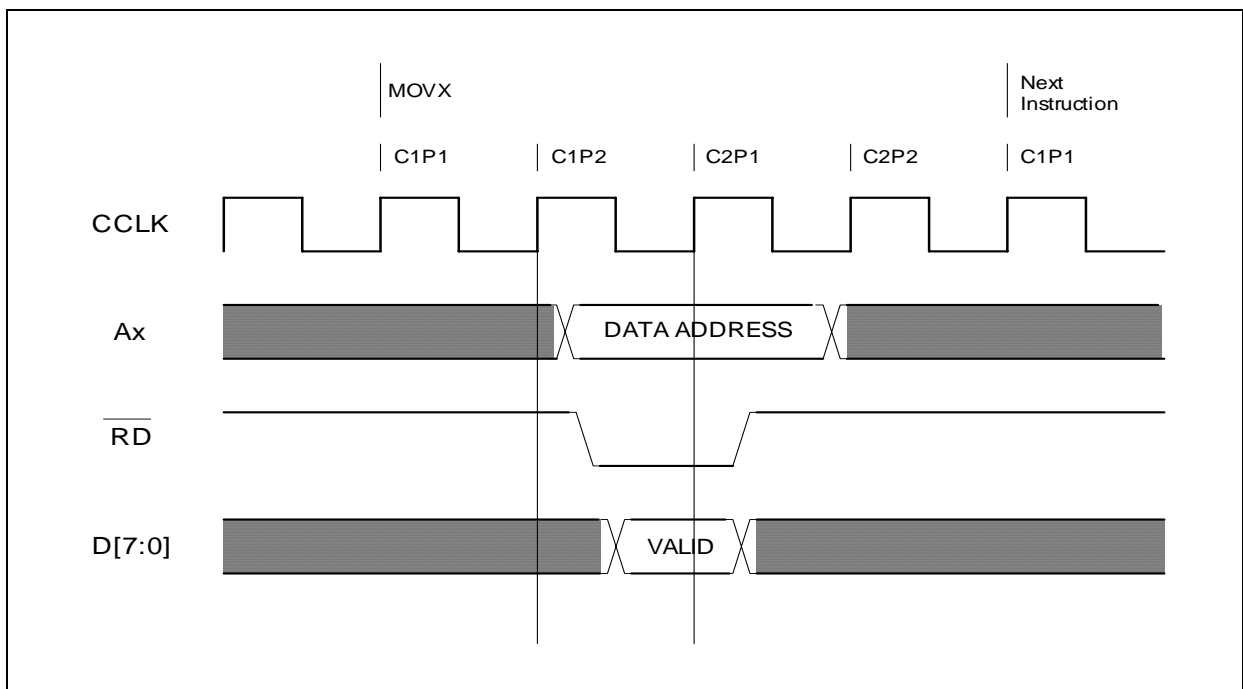
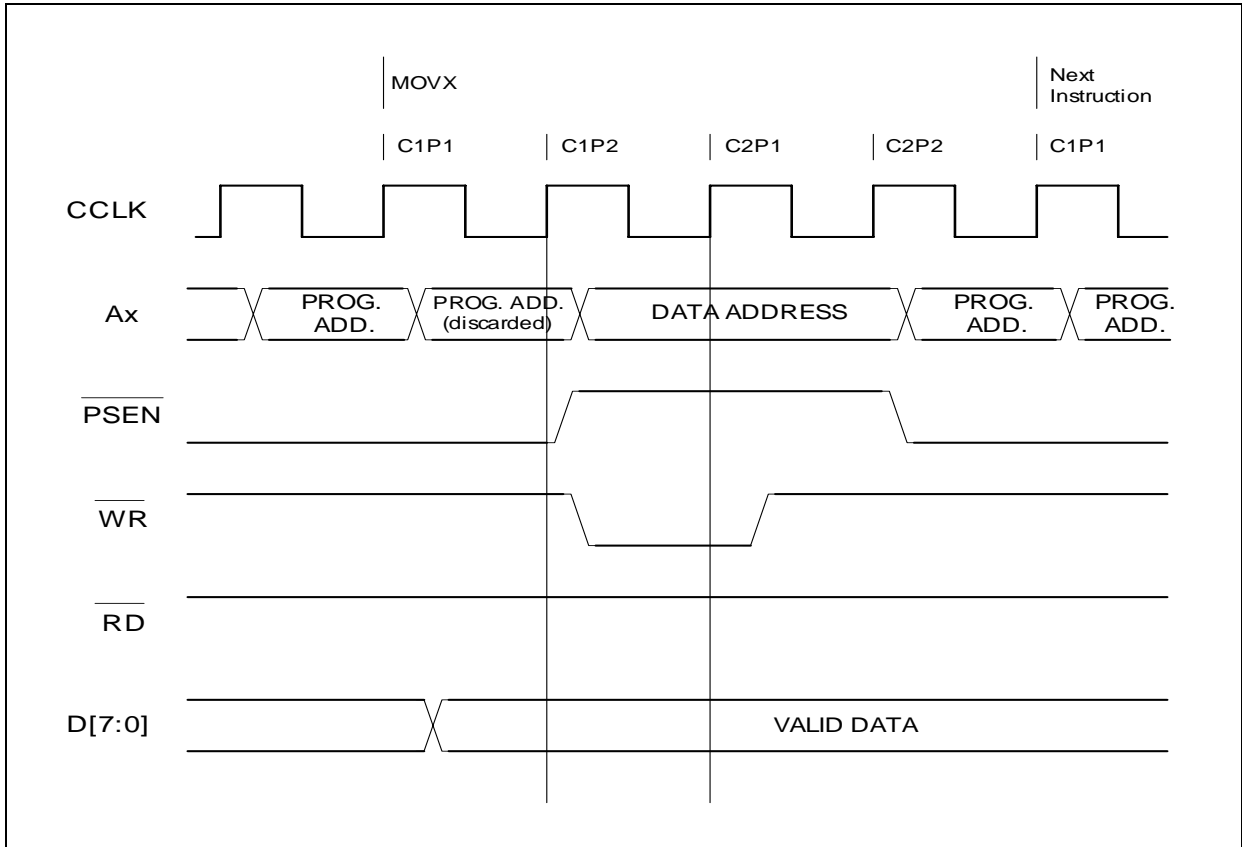

**Figure 3-3 External Data Memory Read Cycle**

CPU Timing

In a write cycle, the data byte to be written appears at the pins before  $\overline{WR}$  is activated, and remains there after  $\overline{WR}$  is deactivated.

**Figure 3-4** shows the timing of the external data memory write cycle. This timing assumes multiplexed program fetch and data access on the external interface.



**Figure 3-4 External Data Memory Write Cycle**

## 4 Instruction Set

The XC800 8-bit microcontroller family instruction set includes the 111 instructions of the standard 8051, plus 2 additional instructions, *MOVC @(DPTR++),A* and *TRAP*, which are multiplexed and selected through the Special Function Register (SFR) EO. Out of the 113 instructions, 51 are single-byte, 46 are two-byte and 16 are three-byte.

The instruction opcode format consists of a function mnemonic that is usually followed by a “destination, source” operand field. This field specifies the data type and addressing method(s) to be used.

### 4.1 Addressing Modes

The XC800 uses five general addressing modes:

- register
- direct
- immediate
- register indirect
- base register plus index-register indirect

**Table 4-1** summarizes the memory space(s) that may be accessed by each addressing mode.

**Table 4-1 Addressing Mode and Associated Memory Space**

| Addressing Mode                              | Associated Memory Space   |
|--|---|
| Register addressing                          | R0 through R7 of selected register bank, ACC, B, CY (Bit), DPTR     |
| Direct addressing                            | Lower 128 bytes of internal RAM, special function registers         |
| Immediate addressing                         | Program memory  |
| Register indirect addressing                 | Internal RAM (@R1, @R0, SP), external data memory (@R1, @R0, @DPTR) |
| Base register plus index register addressing | Program memory (@A + DPTR, @A + PC)                                 |
| Register addressing                          | R0 through R7 of selected register bank, ACC, B, CY (Bit), DPTR     |

### Register Addressing

Register addressing accesses the eight working registers (R0 - R7) of the selected register bank. The least significant bit of the instruction opcode indicates which register is to be used. Some instructions only operate on specific registers such as ACC (A), B, DPTR, or on the bit CY (the Boolean accumulator).

### **Direct Addressing**

Direct addressing is the only method of accessing the SFRs. The lower 128 bytes of internal RAM are also directly addressable. In direct addressing, the operand is specified by an 8-bit address field.

### **Immediate Addressing**

Immediate addressing allows constants to be part of the instruction in program memory. These instructions are 2 or more bytes long.

### **Register Indirect Addressing**

Register indirect addressing uses the contents of either R0 or R1 (in the selected register bank) as a pointer to locations in a 256-byte block: the 256 bytes of internal RAM or the lower 256 bytes of external data memory. Note that the SFRs are not accessible by this method. The upper half of the internal RAM can be accessed by indirect addressing only. Access to the full 64 Kbytes of the active bank of the external data memory address space is accomplished by using the 16-bit data pointer.

### **Base Register plus Index Register Addressing**

Base register plus index register addressing allows a byte to be accessed from program memory via an indirect move from the location whose address is the sum of a base register (DPTR or PC) and index register ACC. This mode facilitates look-up table accesses.

### **Bit Addressing**

Direct bit addressing is supported for bitaddressable locations: bits of bitaddressable SFRs and the 128 bits in the bitaddressable area within the lower internal data RAM.

## 4.2 Introduction to the Instruction Set

The instruction set is divided into six basic functional groups:

- arithmetic
- logic
- data transfer
- control transfer (branching)
- boolean
- miscellaneous

### Arithmetic Instructions

The XC800 microcontrollers have four basic mathematical operations.

- addition: ADD, ADDC, INC, DA
- subtraction: SUBB, DEC
- multiplication: MUL
- division: DIV

Only 8-bit operations using unsigned arithmetic are supported directly. The overflow flag, however, permits the addition and subtraction operations to handle both unsigned and signed binary integers. Arithmetic can also be performed directly on packed BCD representations.

### Logic Instructions

The XC800 microcontrollers perform basic logic operations on both bit and byte operands: ANL, ORL, SRL, CLR, SETB, CPL, RL, RLC, RR, RRC, SWAP.

### Data Transfer Instructions

Data transfer operations are divided into three classes:

- general-purpose
- accumulator-specific
- address-object

None of these operations affects the PSW flag settings except a POP or MOV directly to the PSW.

### Control Transfer Instructions

All control transfer operations, some upon a specific condition, cause the program execution to continue to a non-sequential location in program memory. There are three classes of control transfer operations:

- unconditional jumps
- conditional jumps
- subroutine/interrupt calls and returns



---

## Instruction Set

Unconditional jumps transfer control from the current value of the program counter to the target address. These instructions are: AJMP, LJMP, SJMP and JMP @A + DPTR.

Conditional jumps perform a jump contingent upon a specific condition. The destination will be within a 256-byte range centered about the starting address of the next instruction (– 128 to + 127): JZ, JNZ, JC, JNC, JB, JNB, JBC, CJNE, DJNZ.

There are only 2 types of subroutine call: ACALL and LCALL. Interrupt call is controlled by hardware. Return instructions are RET and RETI. RETI is used for return from interrupt, which restores interrupt priority to that of the current priority level.

### Boolean Instructions

The bitaddressable registers in both direct and SFR space may be manipulated using Boolean instructions. The bit manipulation instructions allow:

- set bit
- clear bit
- complement bit
- jump if bit is set
- jump if bit is not set
- jump if bit is set and clear bit
- move bit from / to carry

Addressable bits, or their complements, may be logically AND-ed or OR-ed with the contents of the carry flag. The result is stored in the carry bit.

### Miscellaneous Instructions

These instructions are:

- NOP: no operation
- TRAP: software break command

### 4.3 Instructions

The XC800 instructions can essentially be condensed to 55 basic operations. These operations are described in detail in the following sections.

#### 4.3.1 Affected Flags

Some instructions affect one or more of the PSW flags, as generally shown in [Table 4-2](#).

**Table 4-2 PSW Flag Modification (CY,OV,AC)**

| Instruction | Flag |    |    | Instruction | Flag |    |    |
|-------------|------|----|----|-------------|------|----|----|
|             | CY   | OV | AC |             | CY   | OV | AC |
| ADD         | X    | X  | X  | SETB C      | 1    |    |    |
| ADDC        | X    | X  | X  | CLR C       | 0    |    |    |
| SUBB        | X    | X  | X  | CPL C       | X    |    |    |
| MUL         | 0    | X  |    | ANL C,bit   | X    |    |    |
| DIV         | 0    | X  |    | ANL C,/bit  | X    |    |    |
| DA          | X    |    |    | ORL C,bit   | X    |    |    |
| RRC         | X    |    |    | ORL C,/bit  | X    |    |    |
| RLC         | X    |    |    | MOV C,bit   | X    |    |    |
| CJNE        | X    |    |    |             |      |    |    |

In the above table, a “0” means the flag is always cleared, a “1” means the flag is always set and an “X” means that the state of the flag depends on the result of the operation. A blank cell indicates that the flag is unaffected by the instruction.

Only the carry, auxiliary carry, and overflow flags are discussed above. The parity bit is always computed from the actual content of the accumulator.

- CY is set if the operation causes a carry to or a borrow from the resulting high-order bit; otherwise CY is cleared.
- AC is set if the operation results in a carry from the low-order four bits of the result (during addition), or a borrow from the high-order bits to the low-order bits (during subtraction); otherwise AC is cleared.
- OV is set if the operation results in a carry to the high-order bit of the result but not a carry from the bit, or vice versa; otherwise OV is cleared. OV is used in twos complement arithmetic, because it is set when the signal result cannot be represented in 8 bits.
- P is set if the modulo-2 sum of the eight bits in the accumulator is 1 (odd parity); otherwise P is cleared (even parity). When a value is written to the PSW register, the P bit remains unchanged, as it always reflects the parity of A.

**Instruction Set**

Instructions that directly alter addressed registers could affect the other status flags if the instruction is applied to the PSW. Status flags can also be modified by bit manipulation.

### 4.3.2 Instruction Table

**Table 4-3** lists all the instructions supported by XC800. Instructions are 1, 2 or 3 bytes long as indicated in the 'Bytes' column. Each instruction takes 1, 2 or 4 machine cycles to execute (with no wait state). One machine cycle comprises 2 CCLK clock cycles.

**Table 4-3 Instruction Table**

| Mnemonic          | Description                                 | Hex Code | Bytes | Cycles |
|-------------------|---|----------|-------|--------|
| <b>ARITHMETIC</b> |   |          |       |        |
| ADD A,Rn          | Add register to A                           | 28-2F    | 1     | 1      |
| ADD A,direct      | Add direct byte to A                        | 25       | 2     | 1      |
| ADD A,@Ri         | Add indirect memory to A                    | 26-27    | 1     | 1      |
| ADD A,#data       | Add immediate to A                          | 24       | 2     | 1      |
| ADDC A,Rn         | Add register to A with carry                | 38-3F    | 1     | 1      |
| ADDC A,direct     | Add direct byte to A with carry             | 35       | 2     | 1      |
| ADDC A,@Ri        | Add indirect memory to A with carry         | 36-37    | 1     | 1      |
| ADDC A,#data      | Add immediate to A with carry               | 34       | 2     | 1      |
| SUBB A,Rn         | Subtract register from A with borrow        | 98-9F    | 1     | 1      |
| SUBB A,direct     | Subtract direct byte from A with borrow     | 95       | 2     | 1      |
| SUBB A,@Ri        | Subtract indirect memory from A with borrow | 96-97    | 1     | 1      |
| SUBB A,#data      | Subtract immediate from A with borrow       | 94       | 2     | 1      |
| INC A             | Increment A                                 | 04       | 1     | 1      |
| INC Rn            | Increment register                          | 08-0F    | 1     | 1      |
| INC direct        | Increment direct byte                       | 05       | 2     | 1      |
| INC @Ri           | Increment indirect memory                   | 06-07    | 1     | 1      |
| DEC A             | Decrement A                                 | 14       | 1     | 1      |
| DEC Rn            | Decrement register                          | 18-1F    | 1     | 1      |
| DEC direct        | Decrement direct byte                       | 15       | 2     | 1      |
| DEC @Ri           | Decrement indirect memory                   | 16-17    | 1     | 1      |

**Table 4-3 Instruction Table (cont'd)**

| <b>Mnemonic</b>  | <b>Description</b>                    | <b>Hex Code</b> | <b>Bytes</b> | <b>Cycles</b> |
|------------------|---------------------------------------|-----------------|--------------|---------------|
| INC DPTR         | Increment data pointer                | A3              | 1            | 2             |
| MUL AB           | Multiply A by B                       | A4              | 1            | 4             |
| DIV AB           | Divide A by B                         | 84              | 1            | 4             |
| DA A             | Decimal Adjust A                      | D4              | 1            | 1             |
| <b>LOGICAL</b>   |                                       |                 |              |               |
| ANL A,Rn         | AND register to A                     | 58-5F           | 1            | 1             |
| ANL A,direct     | AND direct byte to A                  | 55              | 2            | 1             |
| ANL A,@Ri        | AND indirect memory to A              | 56-57           | 1            | 1             |
| ANL A,#data      | AND immediate to A                    | 54              | 2            | 1             |
| ANL direct,A     | AND A to direct byte                  | 52              | 2            | 1             |
| ANL direct,#data | AND immediate to direct byte          | 53              | 3            | 2             |
| ORL A,Rn         | OR register to A                      | 48-4F           | 1            | 1             |
| ORL A,direct     | OR direct byte to A                   | 45              | 2            | 1             |
| ORL A,@Ri        | OR indirect memory to A               | 46-47           | 1            | 1             |
| ORL A,#data      | OR immediate to A                     | 44              | 2            | 1             |
| ORL direct,A     | OR A to direct byte                   | 42              | 2            | 1             |
| ORL direct,#data | OR immediate to direct byte           | 43              | 3            | 2             |
| XRL A,Rn         | Exclusive-OR register to A            | 68-6F           | 1            | 1             |
| XRL A,direct     | Exclusive-OR direct byte to A         | 65              | 2            | 1             |
| XRL A,@Ri        | Exclusive-OR indirect memory to A     | 66-67           | 1            | 1             |
| XRL A,#data      | Exclusive-OR immediate to A           | 64              | 2            | 1             |
| XRL direct,A     | Exclusive-OR A to direct byte         | 62              | 2            | 1             |
| XRL direct,#data | Exclusive-OR immediate to direct byte | 63              | 3            | 2             |
| CLR A            | Clear A                               | E4              | 1            | 1             |
| CPL A            | Complement A                          | F4              | 1            | 1             |
| SWAP A           | Swap Nibbles of A                     | C4              | 1            | 1             |
| RL A             | Rotate A left                         | 23              | 1            | 1             |
| RLC A            | Rotate A left through carry           | 33              | 1            | 1             |
| RR A             | Rotate A right                        | 03              | 1            | 1             |

**Table 4-3 Instruction Table (cont'd)**

| <b>Mnemonic</b>      | <b>Description</b>                  | <b>Hex Code</b> | <b>Bytes</b> | <b>Cycles</b> |
|----------------------|-------------------------------------|-----------------|--------------|---------------|
| RRC A                | Rotate A right through carry        | 13              | 1            | 1             |
| <b>DATA TRANSFER</b> |                                     |                 |              |               |
| MOV A,Rn             | Move register to A                  | E8-EF           | 1            | 1             |
| MOV A,direct         | Move direct byte to A               | E5              | 2            | 1             |
| MOV A,@Ri            | Move indirect memory to A           | E6-E7           | 1            | 1             |
| MOV A,#data          | Move immediate to A                 | 74              | 2            | 1             |
| MOV Rn,A             | Move A to register                  | F8-FF           | 1            | 1             |
| MOV Rn,direct        | Move direct byte to register        | A8-AF           | 2            | 2             |
| MOV Rn,#data         | Move immediate to register          | 78-7F           | 2            | 1             |
| MOV direct,A         | Move A to direct byte               | F5              | 2            | 1             |
| MOV direct,Rn        | Move register to direct byte        | 88-8F           | 2            | 2             |
| MOV direct,direct    | Move direct byte to direct byte     | 85              | 3            | 2             |
| MOV direct,@Ri       | Move indirect memory to direct byte | 86-87           | 2            | 2             |
| MOV direct,#data     | Move immediate to direct byte       | 75              | 3            | 2             |
| MOV @Ri,A            | Move A to indirect memory           | F6-F7           | 1            | 1             |
| MOV @Ri,direct       | Move direct byte to indirect memory | A6-A7           | 2            | 2             |
| MOV @Ri,#data        | Move immediate to indirect memory   | 76-77           | 2            | 1             |
| MOV DPTR,#data16     | Move immediate to data pointer      | 90              | 3            | 2             |
| MOVC A,@A+DPTR       | Move code byte relative DPTR to A   | 93              | 1            | 2             |
| MOVC A,@A+PC         | Move code byte relative PC to A     | 83              | 1            | 2             |
| MOVX A,@Ri           | Move external data (A8) to A        | E2-E3           | 1            | 2             |
| MOVX A,@DPTR         | Move external data (A16) to A       | E0              | 1            | 2             |
| MOVX @Ri,A           | Move A to external data (A8)        | F2-F3           | 1            | 2             |
| MOVX @DPTR,A         | Move A to external data (A16)       | F0              | 1            | 2             |
| PUSH direct          | Push direct byte onto stack         | C0              | 2            | 2             |
| POP direct           | Pop direct byte from stack          | D0              | 2            | 2             |
| XCH A,Rn             | Exchange A and register             | C8-CF           | 1            | 1             |

**Instruction Set**
**Table 4-3 Instruction Table (cont'd)**

| <b>Mnemonic</b>  | <b>Description</b>                        | <b>Hex Code</b> | <b>Bytes</b> | <b>Cycles</b> |
|------------------|---|-----------------|--------------|---------------|
| XCH A,direct     | Exchange A and direct byte                | C5              | 2            | 1             |
| XCH A,@Ri        | Exchange A and indirect memory            | C6-C7           | 1            | 1             |
| XCHD A,@Ri       | Exchange A and indirect memory nibble     | D6-D7           | 1            | 1             |
| <b>BOOLEAN</b>   |   |                 |              |               |
| CLR C            | Clear carry                               | C3              | 1            | 1             |
| CLR bit          | Clear direct bit                          | C2              | 2            | 1             |
| SETB C           | Set carry                                 | D3              | 1            | 1             |
| SETB bit         | Set direct bit                            | D2              | 2            | 1             |
| CPL C            | Complement carry                          | B3              | 1            | 1             |
| CPL bit          | Complement direct bit                     | B2              | 2            | 1             |
| ANL C,bit        | AND direct bit to carry                   | 82              | 2            | 2             |
| ANL C,/bit       | AND direct bit inverse to carry           | B0              | 2            | 2             |
| ORL C,bit        | OR direct bit to carry                    | 72              | 2            | 2             |
| ORL C,/bit       | OR direct bit inverse to carry            | A0              | 2            | 2             |
| MOV C,bit        | Move direct bit to carry                  | A2              | 2            | 1             |
| MOV bit,C        | Move carry to direct bit                  | 92              | 2            | 2             |
| <b>BRANCHING</b> |   |                 |              |               |
| ACALL addr11     | Absolute call within current 2 K          | 11->F1          | 2            | 2             |
| LCALL addr16     | Long call to addr16                       | 12              | 3            | 2             |
| RET              | Return from subroutine                    | 22              | 1            | 2             |
| RETI             | Return from interrupt routine             | 32              | 1            | 2             |
| AJMP addr11      | Absolute jump within current 2 K          | 01->E1          | 2            | 2             |
| LJMP addr16      | Long jump unconditional                   | 02              | 3            | 2             |
| SJMP rel         | Short jump to relative address            | 80              | 2            | 2             |
| JC rel           | Jump relative on carry = 1                | 40              | 2            | 2             |
| JNC rel          | Jump relative on carry = 0                | 50              | 2            | 2             |
| JB bit,rel       | Jump relative on direct bit = 1           | 20              | 3            | 2             |
| JNB bit,rel      | Jump relative on direct bit = 0           | 30              | 3            | 2             |
| JBC bit,rel      | Jump relative and clear on direct bit = 1 | 10              | 3            | 2             |

**Table 4-3 Instruction Table (cont'd)**

| <b>Mnemonic</b>   | <b>Description</b>   | <b>Hex Code</b> | <b>Bytes</b> | <b>Cycles</b> |
|---|--|-----------------|--------------|---------------|
| JMP @A+DPTR   | Jump indirect relative DPTR  | 73              | 1            | 2             |
| JZ rel  | Jump relative on accumulator = 0   | 60              | 2            | 2             |
| JNZ rel   | Jump relative on accumulator = 1   | 70              | 2            | 2             |
| CJNE A,direct,rel   | Compare direct memory to accumulator, jump relative if not equal   | B5              | 3            | 2             |
| CJNE A,#data,rel  | Compare immediate to accumulator, jump relative if not equal   | B4              | 3            | 2             |
| CJNE Rn,#data,rel   | Compare immediate to register, jump relative if not equal  | B8-BF           | 3            | 2             |
| CJNE @Ri,#data,rel  | Compare immediate to indirect memory, jump relative if not equal   | B6-B7           | 3            | 2             |
| DJNZ Rn,rel   | Decrement register and jump relative if not zero   | D8-DF           | 2            | 2             |
| DJNZ direct,rel   | Decrement direct memory and jump relative if not zero  | D5              | 3            | 2             |
| <b>MISCELLANEOUS</b>                                      |  |                 |              |               |
| NOP   | No operation   | 00              | 1            | 1             |
| <b>ADDITIONAL INSTRUCTIONS (selected through EO[7:4])</b> |  |                 |              |               |
| MOVC<br>@(DPTR++),A                                       | XC800-specific instruction for software download into program memory: Copy from accumulator, then increment DPTR | A5              | 1            | 2             |
| TRAP  | XC800-specific software break command  | A5              | 1            | 1             |

### Notes on Data Addressing Modes:

- Rn - Working register R0-R7
- direct - 128 internal RAM locations, special function registers
- @Ri - Indirect internal or external RAM location addressed by register R0 or R1
- #data - 8-bit constant included in instruction
- #data16 - 16-bit constant included in instruction
- bit - 128 bit-addressable bits of lower internal data RAM, any bit-addressable bits of special function registers
- A - Accumulator

### Notes on Program Addressing Modes:

- addr16 - Destination address for LCALL and LJMP may be anywhere within the 64 Kbytes of the active bank located in program space.
- addr11 - Destination address for ACALL and AJMP will be within the same 2-Kbyte page of program memory as the first byte of the following instruction.
- rel - SJMP and all conditional jumps include an 8-bit offset byte. Range is + 127/- 128 bytes relative to the first byte of the following instruction.

All mnemonics copyrighted:  $\Omega$  Intel Corporation 1980

### 4.3.3 Instruction Definitions

The instructions are grouped according to basic operation, and described in alphabetical order according to the operation mnemonic.



**ACALL    addr11**

Function:        Absolute call

Description:    ACALL unconditionally calls a subroutine located at the indicated address. The instruction increments the PC twice to obtain the address of the following instruction, then pushes the 16-bit result onto the stack (low-order byte first) and increments the stack pointer twice. The destination address is obtained by successively concatenating the five high-order bits of the incremented PC, opcode bits 7-5, and the second byte of the instruction. The subroutine called must therefore start within the same 2-Kbyte block of program memory as the first byte of the instruction following ACALL. No flags are affected.

Example:        Initially SP equals 07<sub>H</sub>. The label "SUBRTN" is at program memory location 0345<sub>H</sub>. After executing the instruction

```
ACALL    SUBRTN
```

at location 0123<sub>H</sub>, SP will contain 09<sub>H</sub>, internal RAM location 08<sub>H</sub> and 09<sub>H</sub> will contain 25<sub>H</sub> and 01<sub>H</sub>, respectively, and the PC will contain 0345<sub>H</sub>.

Operation:      ACALL  
                   (PC)    (PC) + 2  
                   (SP)    (SP) + 1  
                   ((SP)) (PC7-0)  
                   (SP)    (SP) + 1  
                   ((SP)) (PC15-8)  
                   (PC10-0)    page address

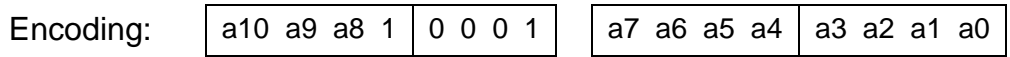

Bytes:            2

Cycles:           2

**ADD A, <src-byte>**

Function: Add

Description: ADD adds the byte variable indicated to the accumulator, leaving the result in the accumulator. The carry and auxiliary carry flags are set, respectively, if there is a carry out of bit 7 or bit 3, and cleared otherwise. When adding unsigned integers, the carry flag indicates an overflow occurred.

OV is set if there is a carry out of bit 6 but not out of bit 7, or a carry out of bit 7 but not out of bit 6; otherwise OV is cleared. When adding signed integers, OV indicates a negative number produced as the sum of two positive operands, or a positive sum from two negative operands.

Four source operand addressing modes are allowed: register, direct, register-indirect, or immediate.

Example: The accumulator holds 0C3<sub>H</sub> (11000011<sub>B</sub>) and register 0 holds 0AA<sub>H</sub> (10101010<sub>B</sub>).  
The instruction

ADD A,R0

will leave 6D<sub>H</sub> (01101101<sub>B</sub>) in the accumulator with the AC flag cleared and both the carry flag and OV set to 1.

**ADD A,Rn**

Operation: ADD  
(A) (A) + (Rn)

Encoding: 

|         |         |
|---------|---------|
| 0 0 1 0 | 1 r r r |
|---------|---------|

Bytes: 1

Cycles: 1

**ADD A,direct**

Operation: ADD  
(A) (A) + (direct)

Encoding: 

|         |         |
|---------|---------|
| 0 0 1 0 | 0 1 0 1 |
|---------|---------|

|                |
|----------------|
| direct address |
|----------------|

Bytes: 2

Cycles: 1

**ADD A, @Ri**

Operation: ADD  
 (A) (A) + ((Ri))

Encoding: 

|         |         |
|---------|---------|
| 0 0 1 0 | 0 1 1 i |
|---------|---------|

Bytes: 1

Cycles: 1

**ADD A, #data**

Operation: ADD  
 (A) (A) + #data

Encoding: 

|         |         |
|---------|---------|
| 0 0 1 0 | 0 1 0 0 |
|---------|---------|

|                |
|----------------|
| immediate data |
|----------------|

Bytes: 2

Cycles: 1

**ADDC A, < src-byte>**

Function: Add with carry

Description: ADDC simultaneously adds the byte variable indicated, the carry flag and the accumulator contents, leaving the result in the accumulator. The carry and auxiliary carry flags are set, respectively, if there is a carry out of bit 7 or bit 3, and cleared otherwise. When adding unsigned integers, the carry flag indicates an overflow occurred.

OV is set if there is a carry out of bit 6 but not out of bit 7, or a carry out of bit 7 but not out of bit 6; otherwise OV is cleared. When adding signed integers, OV indicates a negative number produced as the sum of two positive operands or a positive sum from two negative operands.

Four source operand addressing modes are allowed: register, direct, register-indirect, or immediate.

Example: The accumulator holds 0C3<sub>H</sub> (11000011<sub>B</sub>) and register 0 holds 0AA<sub>H</sub> (10101010<sub>B</sub>) with the carry flag set. The instruction

ADDC A,R0

will leave 6E<sub>H</sub> (01101110<sub>B</sub>) in the accumulator with AC cleared and both the carry flag and OV set to 1.

**ADDC A,Rn**

Operation: ADDC  
(A) (A) + (C) + (Rn)

Encoding: 

|         |         |
|---------|---------|
| 0 0 1 1 | 1 r r r |
|---------|---------|

Bytes: 1

Cycles: 1

**ADDC A,direct**

Operation: ADDC  
(A) (A) + (C) + (direct)

Encoding: 

|         |         |
|---------|---------|
| 0 0 1 1 | 0 1 0 1 |
|---------|---------|

|                |
|----------------|
| direct address |
|----------------|

Bytes: 2

Cycles: 1

**ADDC A, @Ri**

Operation: ADDC  
 (A) (A) + (C) + ((Ri))

Encoding: 

|         |         |
|---------|---------|
| 0 0 1 1 | 0 1 1 i |
|---------|---------|

Bytes: 1

Cycles: 1

**ADDC A, #data**

Operation: ADDC  
 (A) (A) + (C) + #data

Encoding: 

|         |         |
|---------|---------|
| 0 0 1 1 | 0 1 0 0 |
|---------|---------|

|                |
|----------------|
| immediate data |
|----------------|

Bytes: 2

Cycles: 1

**AJMP    addr11**

Function:     Absolute jump

Description:    AJMP transfers program execution to the indicated address, which is formed at run-time by concatenating the high-order five bits of the PC (*after* incrementing the PC twice), opcode bits 7-5, and the second byte of the instruction. The destination must therefore be within the same 2-Kbyte block of program memory as the first byte of the instruction following AJMP.

Example:        The label “JMPADR” is at program memory location 0123<sub>H</sub>. The instruction  
AJMP    JMPADR  
is at location 0345<sub>H</sub> and will load the PC with 0123<sub>H</sub>.

Operation:     AJM P  
(PC)    (PC) + 2  
(PC10-0)    page address

Encoding:      

|     |    |    |   |   |   |   |   |
|-----|----|----|---|---|---|---|---|
| a10 | a9 | a8 | 0 | 0 | 0 | 0 | 1 |
|-----|----|----|---|---|---|---|---|

|    |    |    |    |    |    |    |    |
|----|----|----|----|----|----|----|----|
| a7 | a6 | a5 | a4 | a3 | a2 | a1 | a0 |
|----|----|----|----|----|----|----|----|

Bytes:         2

Cycles:        2

**ANL <dest-byte>, <src-byte>**

Function: Logical AND for byte variables

Description: ANL performs the bitwise logical AND operation between the variables indicated and stores the results in the destination variable. No flags are affected (except P, if <dest-byte> = A).

The two operands allow six addressing mode combinations. When the destination is the accumulator, the source can use register, direct, register-indirect, or immediate addressing; when the destination is a direct address, the source can be the accumulator or immediate data.

**Note:**

When this instruction is used to modify an output port, the value used as the original port data will be read from the output data latch, not the input pins.

Example: If the accumulator holds 0C3<sub>H</sub> (11000011<sub>B</sub>) and register 0 holds 0AA<sub>H</sub> (10101010<sub>B</sub>) then the instruction

ANL A,R0

will leave 81<sub>H</sub> (10000001<sub>B</sub>) in the accumulator.

When the destination is a directly addressed byte, this instruction will clear combinations of bits in any RAM location or hardware register. The mask byte determining the pattern of bits to be cleared would either be a constant contained in the instruction or a value computed in the accumulator at run-time.

The instruction

ANL P1, #01110011<sub>B</sub>

will clear bits 7, 3, and 2 of output port 1.

**ANL A,Rn**

Operation: ANL  
(A) (A) (Rn)

Encoding: 

|         |         |
|---------|---------|
| 0 1 0 1 | 1 r r r |
|---------|---------|

Bytes: 1

Cycles: 1

**ANL A,direct**

Operation: ANL  
(A) (A) (direct)

Encoding: 

|         |         |
|---------|---------|
| 0 1 0 1 | 0 1 0 1 |
|---------|---------|

|                |
|----------------|
| direct address |
|----------------|

Bytes: 2

Cycles: 1

**ANL A, @Ri**

Operation: ANL  
(A) (A) ((Ri))

Encoding: 

|         |         |
|---------|---------|
| 0 1 0 1 | 0 1 1 i |
|---------|---------|

Bytes: 1

Cycles: 1

**ANL A, #data**

Operation: ANL  
(A) (A) #data

Encoding: 

|         |         |
|---------|---------|
| 0 1 0 1 | 0 1 0 0 |
|---------|---------|

|                |
|----------------|
| immediate data |
|----------------|

Bytes: 2

Cycles: 1

**ANL direct,A**

Operation: ANL  
(direct) (direct) (A)

Encoding: 

|         |         |
|---------|---------|
| 0 1 0 1 | 0 0 1 0 |
|---------|---------|

|                |
|----------------|
| direct address |
|----------------|

Bytes: 2

Cycles: 1



**ANL      direct, #data**

Operation:    ANL  
                 (direct) (direct) #data

Encoding:    

|   |   |   |   |   |   |   |   |
|---|---|---|---|---|---|---|---|
| 0 | 1 | 0 | 1 | 0 | 0 | 1 | 1 |
|---|---|---|---|---|---|---|---|

|                |
|----------------|
| direct address |
|----------------|

|                |
|----------------|
| immediate data |
|----------------|

Bytes:        3

Cycles:      2

**ANL C, <src-bit>**

Function: Logical AND for bit variables

Description: If the Boolean value of the source bit is a logic 0 then clear the carry flag; otherwise leave the carry flag in its current state. A slash (“/”) preceding the operand in the assembly language indicates that the logical complement of the addressed bit is used as the source value, *but the source bit itself is not affected*. No other flags are affected.

Only direct bit addressing is allowed for the source operand.

Example: Set the carry flag if, and only if, P1.0 = 1, ACC.7 = 1, and OV = 0:

```
MOV    C,P1.0           ; Load carry with input pin state
ANL    C,ACC.7         ; AND carry with accumulator bit 7
ANL    C,/OV           ; AND with inverse of overflow flag
```

**ANL C,bit**

Operation: ANL  
(C) (C) (bit)

Encoding: 

|         |         |
|---------|---------|
| 1 0 0 0 | 0 0 1 0 |
|---------|---------|

|             |
|-------------|
| bit address |
|-------------|

Bytes: 2

Cycles: 2

**ANL C,/bit**

Operation: ANL  
(C) (C) / (bit)

Encoding: 

|         |         |
|---------|---------|
| 1 0 1 1 | 0 0 0 0 |
|---------|---------|

|             |
|-------------|
| bit address |
|-------------|

Bytes: 2

Cycles: 2

**CJNE <dest-byte >, < src-byte >, rel**

Function: Compare and jump if not equal

Description: CJNE compares the magnitudes of the first two operands, and branches if their values are not equal. The branch destination is computed by adding the signed relative displacement in the last instruction byte to the PC, after incrementing the PC to the start of the next instruction. The carry flag is set if the unsigned integer value of <dest-byte> is less than the unsigned integer value of <src-byte>; otherwise, the carry is cleared. Neither operand is affected.

The first two operands allow four addressing mode combinations: the accumulator may be compared with any directly addressed byte or immediate data, and any indirect RAM location or working register can be compared with an immediate constant.

Example: The accumulator contains 34<sub>H</sub>. Register 7 contains 56<sub>H</sub>. The first instruction in the sequence

```

                CJNE    R7, # 60H, NOT_EQ
;
;                ...    .....
NOT_EQ         JC      REQ_LOW           ; R7 = 60H
;                ...    .....           ; If R7 < 60H
;                ...    .....           ; R7 > 60H

```

sets the carry flag and branches to the instruction at label NOT\_EQ. By testing the carry flag, this instruction determines whether R7 is greater or less than 60<sub>H</sub>.

If the data being presented to port 1 is also 34<sub>H</sub>, then the instruction

```
WAIT:  CJNE  A,P1,WAIT
```

clears the carry flag and continues with the next instruction in sequence, since the accumulator does equal the data read from P1. (If some other value was input on P1, the program will loop at this point until the P1 data changes to 34<sub>H</sub>).

**CJNE A,direct,rel**

Operation: (PC) (PC) + 3  
 if (A) < > (direct)  
 then (PC) (PC) + relative offset  
 if (A) < (direct)  
 then (C) 1  
 else (C) 0

Encoding: 

|         |         |
|---------|---------|
| 1 0 1 1 | 0 1 0 1 |
|---------|---------|

|                |
|----------------|
| direct address |
|----------------|

|              |
|--------------|
| rel. address |
|--------------|

Bytes: 3

Cycles: 2

**CJNE A, #data,rel**

Operation: (PC) (PC) + 3  
 if (A) < > data  
 then (PC) (PC) + relative offset  
 if (A) data  
 then (C) 1  
 else (C) 0

Encoding: 

|         |         |
|---------|---------|
| 1 0 1 1 | 0 1 0 0 |
|---------|---------|

|                |
|----------------|
| immediate data |
|----------------|

|              |
|--------------|
| rel. address |
|--------------|

Bytes: 3

Cycles: 2

**CJNE RN, #data, rel**

Operation: (PC) (PC) + 3  
 if (Rn) < > data  
 then (PC) (PC) + relative offset  
 if (Rn) < data  
 then (C) 1  
 else (C) 0

Encoding: 

|         |         |
|---------|---------|
| 1 0 1 1 | 1 r r r |
|---------|---------|

|                |
|----------------|
| immediate data |
|----------------|

|              |
|--------------|
| rel. address |
|--------------|

Bytes: 3

Cycles: 2

**CJNE @Ri, #data, rel**

Operation: (PC) (PC) + 3  
 if ((Ri) < > data  
 then (PC) (PC) + relative offset  
 if ((Ri) < data  
 then (C) 1  
 else (C) 0

Encoding: 

|         |         |
|---------|---------|
| 1 0 1 1 | 0 1 1 i |
|---------|---------|

|                |
|----------------|
| immediate data |
|----------------|

|              |
|--------------|
| rel. address |
|--------------|

Bytes: 3

Cycles: 2

**CLR     A**

Function:     Clear accumulator

Description:  The accumulator is cleared (all bits set to zero). No flags are affected.

Example:     The accumulator contains 5C<sub>H</sub> (01011100<sub>B</sub>). The instruction  
CLR     A  
will leave the accumulator set to 00<sub>H</sub> (00000000<sub>B</sub>).

Operation:   CLR  
              (A) 0

Encoding:   

|   |   |   |   |   |   |   |   |
|---|---|---|---|---|---|---|---|
| 1 | 1 | 1 | 0 | 0 | 1 | 0 | 0 |
|---|---|---|---|---|---|---|---|

Bytes:       1

Cycles:      1

**CLR bit**

Function: Clear bit

Description: The indicated bit is cleared (reset to zero). No other flags are affected. CLR can operate on the carry flag or any directly addressable bit.

Example: Port 1 has previously been written with 5D<sub>H</sub> (01011101<sub>B</sub>). The instruction  
CLR P1.2  
will leave the port set to 59<sub>H</sub> (01011001<sub>B</sub>).

**CLR C**

Operation: CLR  
(C) 0

Encoding: 

|         |         |
|---------|---------|
| 1 1 0 0 | 0 0 1 1 |
|---------|---------|

Bytes: 1

Cycles: 1

**CLR bit**

Operation: CLR  
(bit) 0

Encoding: 

|         |         |
|---------|---------|
| 1 1 0 0 | 0 0 1 0 |
|---------|---------|

|             |
|-------------|
| bit address |
|-------------|

Bytes: 2

Cycles: 1

**CPL      A**

Function:      Complement accumulator

Description:    Each bit of the accumulator is logically complemented (ones complement). Bits that previously contained a one are changed to zero and vice versa. No flags are affected.

Example:        The accumulator contains 5C<sub>H</sub> (01011100<sub>B</sub>). The instruction

CPL      A

will leave the accumulator set to 0A3<sub>H</sub> (10100011<sub>B</sub>).

Operation:     CPL

(A)   / (A)

Encoding:

|         |         |
|---------|---------|
| 1 1 1 1 | 0 1 0 0 |
|---------|---------|

Bytes:         1

Cycles:        1



**CPL      bit**

Function:      Complement bit

Description:    The bit variable specified is complemented. A bit that had been a one is changed to zero and vice versa. No other flags are affected. CPL can operate on the carry or any directly addressable bit.

**Note:**

When this instruction is used to modify an output pin, the value used as the original data will be read from the output data latch, not the input pin.

Example:        Port 1 has previously been written with 5D<sub>H</sub> (01011101<sub>B</sub>). The instruction sequence

```
CPL    P1.1
CPL    P1.2
```

will leave the port set to 5B<sub>H</sub> (01011011<sub>B</sub>).

**CPL      C**

Operation:      CPL  
                  (bit) / (C)

Encoding:      

|         |         |
|---------|---------|
| 1 0 1 1 | 0 0 1 1 |
|---------|---------|

Bytes:          1

Cycles:         1

**CPL      bit**

Operation:      CPL  
                  (C) (bit)

Encoding:      

|         |         |
|---------|---------|
| 1 0 1 1 | 0 0 1 0 |
|---------|---------|

|             |
|-------------|
| bit address |
|-------------|

Bytes:          2

Cycles:         1

**DA      A**

Function:      Decimal adjust accumulator for addition

Description:      DA A adjusts the eight-bit value in the accumulator resulting from the earlier addition of two variables (each in packed BCD format), producing two four-bit digits. Any ADD or ADDC instruction may have been used to perform the addition.

If accumulator bits 3-0 are greater than nine (xxxx1010-xxxx1111), or if the AC flag is one, six is added to the accumulator producing the proper BCD digit in the low-order nibble. This internal addition would set the carry flag if a carry-out of the low-order four-bit field propagated through all high-order bits, but it would not clear the carry flag otherwise.

If the carry flag is now set, or if the four high-order bits now exceed nine (1010xxxx-1111xxxx), these high-order bits are incremented by six, producing the proper BCD digit in the high-order nibble. Again, this would set the carry flag if there was a carry-out of the high-order bits, but would not clear the carry. The carry flag thus indicates if the sum of the original two BCD variables is greater than 100, allowing multiple precision decimal addition. OV is not affected.

All of this occurs during the one instruction cycle. Essentially; this instruction performs the decimal conversion by adding 00<sub>H</sub>, 06<sub>H</sub>, 60<sub>H</sub>, or 66<sub>H</sub> to the accumulator, depending on initial accumulator and PSW conditions.

**Note:**

DA A *cannot* simply convert a hexadecimal number in the accumulator to BCD notation, nor does DA A apply to decimal subtraction.

Example:      The accumulator holds the value 56<sub>H</sub> (01010110<sub>B</sub>) representing the packed BCD digits of the decimal number 56. Register 3 contains the value 67<sub>H</sub> (01100111<sub>B</sub>) representing the packed BCD digits of the decimal number 67. The carry flag is set. The instruction sequence

```
ADDC    A,R3
DA      A
```

will first perform a standard twos complement binary addition, resulting in the value 0BE<sub>H</sub> (10111110<sub>B</sub>) in the accumulator. The carry and auxiliary carry flags will be cleared.

The decimal adjust instruction will then alter the accumulator to the value 24<sub>H</sub> (00100100<sub>B</sub>), indicating the packed BCD digits of the decimal number 24, the low-order two digits of the decimal sum of 56, 67, and the carry-in. The carry flag will be set by the decimal adjust instruction, indicating that a decimal overflow occurred. The true sum 56, 67, and 1 is 124.

**Instruction Set**

BCD variables can be incremented or decremented by adding 01<sub>H</sub> or 99<sub>H</sub>. If the accumulator initially holds 30<sub>H</sub> (representing the digits of 30 decimal), then the instruction sequence

```
ADD    A, #99H
DA     A
```

will leave the carry set and 29<sub>H</sub> in the accumulator, since 30 + 99 = 129. The low-order byte of the sum can be interpreted to mean 30 – 1 = 29.

Operation: DA  
 contents of accumulator are BCD  
 if  $[(A3-0) > 9] \quad [(AC) = 1]$   
 then  $(A3-0) \quad (A3-0) + 6$   
 and  
 if  $[(A7-4) > 9] \quad [(C) = 1]$   
 then  $(A7-4) \quad (A7-4) + 6$

Encoding: 

|         |         |
|---------|---------|
| 1 1 0 1 | 0 1 0 0 |
|---------|---------|

Bytes: 1

Cycles: 1

**DEC      byte**

Function:      Decrement

Description:    The variable indicated is decremented by 1. An original value of 00<sub>H</sub> will underflow to 0FF<sub>H</sub>. No flags are affected. Four operand addressing modes are allowed: accumulator, register, direct, or register-indirect.

**Note:**

When this instruction is used to modify an output port, the value used as the original port data will be read from the output data latch, *not* the input pins.

Example:        Register 0 contains 7F<sub>H</sub> (01111111<sub>B</sub>). Internal RAM locations 7E<sub>H</sub> and 7F<sub>H</sub> contain 00<sub>H</sub> and 40<sub>H</sub>, respectively. The instruction sequence

```
DEC     @R0
DEC     R0
DEC     @R0
```

will leave register 0 set to 7E<sub>H</sub> and internal RAM locations 7E<sub>H</sub> and 7F<sub>H</sub> set to 0FF<sub>H</sub> and 3F<sub>H</sub>.

**DEC      A**

Operation:      DEC  
                   (A)    (A) – 1

Encoding:        

|         |         |
|---------|---------|
| 0 0 0 1 | 0 1 0 0 |
|---------|---------|

Bytes:            1

Cycles:           1

**DEC      Rn**

Operation:      DEC  
                   (Rn)    (Rn) – 1

Encoding:        

|         |         |
|---------|---------|
| 0 0 0 1 | 1 r r r |
|---------|---------|

Bytes:            1

Cycles:           1

**DEC      direct**

Operation:    DEC  
                   (direct)    (direct) – 1

Encoding:    

|         |         |
|---------|---------|
| 0 0 0 1 | 0 1 0 1 |
|---------|---------|

|                |
|----------------|
| direct address |
|----------------|

Bytes:        2

Cycles:      1

**DEC      @Ri**

Operation:    DEC  
                   ((Ri))    ((Ri)) – 1

Encoding:    

|         |         |
|---------|---------|
| 0 0 0 1 | 0 1 1 i |
|---------|---------|

Bytes:        1

Cycles:      1

**DIV AB**

Function: Divide

Description: DIV AB divides the unsigned eight-bit integer in the accumulator by the unsigned eight-bit integer in register B. The accumulator receives the integer part of the quotient; register B receives the integer remainder. The carry and OV flags will be cleared.

*Exception:* If B had originally contained 00<sub>H</sub>, the values returned in the accumulator and B register will be undefined and the overflow flag will be set. The carry flag is cleared in any case.

Example: The accumulator contains 251 (0FB<sub>H</sub> or 11111011<sub>B</sub>) and B contains 18 (12<sub>H</sub> or 00010010<sub>B</sub>). The instruction

DIV AB

will leave 13 in the accumulator (0D<sub>H</sub> or 00001101<sub>B</sub>) and the value 17 (11<sub>H</sub> or 00010001<sub>B</sub>) in B, since 251 = (13x18) + 17. Carry and OV will both be cleared.

Operation: DIV

(A15-8) (A) / (B)  
(B7-0)

Encoding: 

|   |   |   |   |   |   |   |   |
|---|---|---|---|---|---|---|---|
| 1 | 0 | 0 | 0 | 0 | 1 | 0 | 0 |
|---|---|---|---|---|---|---|---|

Bytes: 1

Cycles: 4

**DJNZ**    <byte>, <rel-addr>

Function:        Decrement and jump if not zero

Description:    DJNZ decrements the location indicated by 1, and branches to the address indicated by the second operand if the resulting value is not zero. An original value of 00<sub>H</sub> will underflow to 0FF<sub>H</sub>. No flags are affected. The branch destination would be computed by adding the signed relative-displacement value in the last instruction byte to the PC, after incrementing the PC to the first byte of the following instruction. The location decremented may be a register or directly addressed byte.

**Note:**

When this instruction is used to modify an output port, the value used as the original port data will be read from the output data latch, not the input pins.

Example:        Internal RAM locations 40<sub>H</sub>, 50<sub>H</sub>, and 60<sub>H</sub> contain the values, 01<sub>H</sub>, 70<sub>H</sub>, and 15<sub>H</sub>, respectively. The instruction sequence

```
DJNZ 40H,LABEL_1
DJNZ 50H,LABEL_2
DJNZ 60H,LABEL_3
```

will cause a jump to the instruction at label LABEL\_2 with the values 00<sub>H</sub>, 6F<sub>H</sub>, and 15<sub>H</sub> in the three RAM locations. The first jump was *not* taken because the result was zero.

This instruction provides a simple way of executing a program loop a given number of times, or for adding a moderate time delay (from 2 to 512 machine cycles) with a single instruction. The instruction sequence

```
          MOV      R2, #8
TOGGLE:  CPL      P1.7
          DJNZ    R2,TOGGLE
```

will toggle P1.7 eight times, causing four output pulses to appear at bit 7 of output port 1. Each pulse will last three machine cycles; two for DJNZ and one to alter the pin.

**DJNZ Rn,rel**

Operation: DJNZ  
 (PC) (PC) + 2  
 (Rn) (Rn) – 1  
 if (Rn) > 0 or (Rn) < 0  
 then (PC) (PC) + rel

Encoding: 

|         |         |
|---------|---------|
| 1 1 0 1 | 1 r r r |
|---------|---------|

|              |
|--------------|
| rel. address |
|--------------|

Bytes: 2

Cycles: 2

**DJNZ direct,rel**

Operation: DJNZ  
 (PC) (PC) + 2  
 (direct) (direct) – 1  
 if (direct) > 0 or (direct) < 0  
 then (PC) (PC) + rel

Encoding: 

|         |         |
|---------|---------|
| 1 1 0 1 | 0 1 0 1 |
|---------|---------|

|                |
|----------------|
| direct address |
|----------------|

|              |
|--------------|
| rel. address |
|--------------|

Bytes: 3

Cycles: 2



**INC      <byte>**

Function:      Increment

Description:    INC increments the indicated variable by 1. An original value of 0FF<sub>H</sub> will overflow to 00<sub>H</sub>. No flags are affected. Three addressing modes are allowed: register, direct, or register-indirect.

**Note:**

When this instruction is used to modify an output port, the value used as the original port data will be read from the output data latch, *not* the input pins.

Example:        Register 0 contains 7E<sub>H</sub> (01111110<sub>B</sub>). Internal RAM locations 7E<sub>H</sub> and 7F<sub>H</sub> contain 0FF<sub>H</sub> and 40<sub>H</sub>, respectively. The instruction sequence

```
INC      @R0
INC      R0
INC      @R0
```

will leave register 0 set to 7F<sub>H</sub> and internal RAM locations 7E<sub>H</sub> and 7F<sub>H</sub> holding (respectively) 00<sub>H</sub> and 41<sub>H</sub>.

**INC      A**

Operation:      INC  
                  (A)    (A) + 1

Encoding:        

|         |         |
|---------|---------|
| 0 0 0 0 | 0 1 0 0 |
|---------|---------|

Bytes:            1

Cycles:           1

**INC      Rn**

Operation:      INC  
                  (Rn)    (Rn) + 1

Encoding:        

|         |         |
|---------|---------|
| 0 0 0 0 | 1 r r r |
|---------|---------|

Bytes:            1

Cycles:           1

**INC      direct**

Operation:    INC  
                   (direct)    (direct) + 1

Encoding:    

|         |         |
|---------|---------|
| 0 0 0 0 | 0 1 0 1 |
|---------|---------|

|                |
|----------------|
| direct address |
|----------------|

Bytes:        2

Cycles:      1

**INC      @Ri**

Operation:    INC  
                   ((Ri))    ((Ri)) + 1

Encoding:    

|         |         |
|---------|---------|
| 0 0 0 0 | 0 1 1 i |
|---------|---------|

Bytes:        1

Cycles:      1

**INC DPTR**

Function: Increment data pointer

Description: Increment the 16-bit data pointer by 1. A 16-bit increment (modulo  $2^{16}$ ) is performed; an overflow of the low-order byte of the data pointer (DPL) from  $0FF_H$  to  $00_H$  will increment the high-order byte (DPH). No flags are affected.

This is the only 16-bit register which can be incremented.

Example: Registers DPH and DPL contain  $12_H$  and  $0FE_H$ , respectively. The instruction sequence

```
INC DPTR
INC DPTR
INC DPTR
```

will change DPH and DPL to  $13_H$  and  $01_H$ .

Operation: INC  
(DPTR) (DPTR) + 1

Encoding: 

|         |         |
|---------|---------|
| 1 0 1 0 | 0 0 1 1 |
|---------|---------|

Bytes: 1

Cycles: 2

**JB            bit,rel**

Function:        Jump if bit is set

Description:    If the indicated bit is a one, jump to the address indicated; otherwise proceed with the next instruction. The branch destination is computed by adding the signed relative-displacement in the third instruction byte to the PC, after incrementing the PC to the first byte of the next instruction. The bit tested is not modified. No flags are affected.

Example:        The data present at input port 1 is 11001010<sub>B</sub>. The accumulator holds 56 (01010110<sub>B</sub>). The instruction sequence

```
JB        P1.2,LABEL1
JB        ACC.2,LABEL2
```

will cause program execution to branch to the instruction at label LABEL2.

Operation:      JB  
                   (PC)    (PC) + 3  
                   if (bit) = 1  
                   then (PC)    (PC) + rel

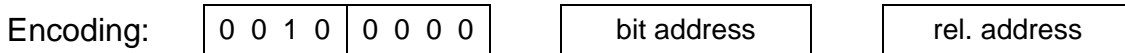

Bytes:            3

Cycles:          2

**JBC bit,rel**

Function: Jump if bit is set and clear bit

Description: If the indicated bit is one, branch to the address indicated; otherwise proceed with the next instruction. *In either case, clear the designated bit.* The branch destination is computed by adding the signed relative displacement in the third instruction byte to the PC, after incrementing the PC to the first byte of the next instruction. No flags are affected.

**Note:**

When this instruction is used to test an output pin, the value used as the original data will be read from the output data latch, not the input pin.

Example: The accumulator holds 56<sub>H</sub> (01010110<sub>B</sub>). The instruction sequence

```
JBC ACC.3,LABEL1
JBC ACC.2,LABEL2
```

will cause program execution to continue at the instruction identified by the label LABEL2, with the accumulator modified to 52<sub>H</sub> (01010010<sub>B</sub>).

Operation: JBC  
(PC) (PC) + 3  
if (bit) = 1  
then (bit) 0  
(PC) (PC) + rel

Encoding: 

|         |         |
|---------|---------|
| 0 0 0 1 | 0 0 0 0 |
|---------|---------|

|             |
|-------------|
| bit address |
|-------------|

|              |
|--------------|
| rel. address |
|--------------|

Bytes: 3

Cycles: 2

**JC            rel**

Function:        Jump if carry is set

Description:    If the carry flag is set, branch to the address indicated; otherwise proceed with the next instruction. The branch destination is computed by adding the signed relative-displacement in the second instruction byte to the PC, after incrementing the PC twice. No flags are affected.

Example:        The carry flag is cleared. The instruction sequence

```
JC        LABEL1
CPL      C
JC        LABEL2
```

will set the carry and cause program execution to continue at the instruction identified by the label LABEL2.

Operation:     JC  
                   (PC)    (PC) + 2  
                   if (C) = 1  
                   then (PC)    (PC) + rel

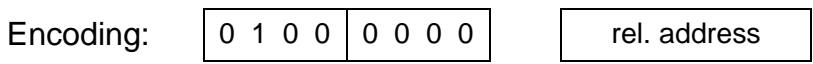

Bytes:         2

Cycles:        2

**JMP @A + DPTR**

Function: Jump indirect

Description: Add the eight-bit unsigned contents of the accumulator with the sixteen-bit data pointer, and load the resulting sum to the program counter. This will be the address for subsequent instruction fetches. Sixteen-bit addition is performed (modulo  $2^{16}$ ): a carry-out from the low-order eight bits propagates through the higher-order bits. Neither the accumulator nor the data pointer is altered. No flags are affected.

Example: An even number from 0 to 6 is in the accumulator. The following sequence of instructions will branch to one of four AJMP instructions in a jump table starting at JMP\_TBL:

```

MOV    DPTR, #JMP_TBL
JMP    @A + DPTR
JMP_TBL: AJMP LABEL0
        AJMP LABEL1
        AJMP LABEL2
        AJMP LABEL3

```

If the accumulator equals  $04_H$  when starting this sequence, execution will jump to label LABEL2. Remember that AJMP is a two-byte instruction, so the jump instructions start at every other address.

Operation: JMP  
(PC) (A) + (DPTR)

Encoding: 

|         |         |
|---------|---------|
| 0 1 1 1 | 0 0 1 1 |
|---------|---------|

Bytes: 1

Cycles: 2

**JNB bit,rel**

Function: Jump if bit is not set

Description: If the indicated bit is a zero, branch to the indicated address; otherwise proceed with the next instruction. The branch destination is computed by adding the signed relative-displacement in the third instruction byte to the PC, after incrementing the PC to the first byte of the next instruction. *The bit tested is not modified.* No flags are affected.

Example: The data present at input port 1 is 11001010<sub>B</sub>. The accumulator holds 56<sub>H</sub> (01010110<sub>B</sub>). The instruction sequence

```
JNB P1.3,LABEL1
JNB ACC.3,LABEL2
```

will cause program execution to continue at the instruction at label LABEL2.

Operation: JNB  
(PC) (PC) + 3  
if (bit) = 0  
then (PC) (PC) + rel.

Encoding: 

|         |         |
|---------|---------|
| 0 0 1 1 | 0 0 0 0 |
|---------|---------|

|             |
|-------------|
| bit address |
|-------------|

|              |
|--------------|
| rel. address |
|--------------|

Bytes: 3

Cycles: 2



**JNC rel**

Function: Jump if carry is not set

Description: If the carry flag is a zero, branch to the address indicated; otherwise proceed with the next instruction. The branch destination is computed by adding the signed relative-displacement in the second instruction byte to the PC, after incrementing the PC twice to point to the next instruction. The carry flag is not modified.

Example: The carry flag is set. The instruction sequence

```
JNC LABEL1
CPL C
JNC LABEL2
```

will clear the carry and cause program execution to continue at the instruction identified by the label LABEL2.

Operation: JNC  
 $(PC) \leftarrow (PC) + 2$   
 if  $(C) = 0$   
 then  $(PC) \leftarrow (PC) + rel$

Encoding: 

|         |         |
|---------|---------|
| 0 1 0 1 | 0 0 0 0 |
|---------|---------|

|              |
|--------------|
| rel. address |
|--------------|

Bytes: 2

Cycles: 2

**JNZ      rel**

Function:      Jump if accumulator is not zero

Description:    If any bit of the accumulator is a one, branch to the indicated address; otherwise proceed with the next instruction. The branch destination is computed by adding the signed relative-displacement in the second instruction byte to the PC, after incrementing the PC twice. The accumulator is not modified. No flags are affected.

Example:        The accumulator originally holds 00<sub>H</sub>. The instruction sequence

```
JNZ      LABEL1
INC      A
JNZ      LABEL2
```

will set the accumulator to 01<sub>H</sub> and continue at label LABEL2.

Operation:     JNZ  
                   (PC)    (PC) + 2  
                   if (A)    0  
                   then (PC)    (PC) + rel.

Encoding:      

|         |         |
|---------|---------|
| 0 1 1 1 | 0 0 0 0 |
|---------|---------|

|              |
|--------------|
| rel. address |
|--------------|

Bytes:            2

Cycles:          2

**JZ            rel**

Function:        Jump if accumulator is zero

Description:    If all bits of the accumulator are zero, branch to the address indicated; otherwise proceed with the next instruction. The branch destination is computed by adding the signed relative-displacement in the second instruction byte to the PC, after incrementing the PC twice. The accumulator is not modified. No flags are affected.

Example:        The accumulator originally contains 01<sub>H</sub>. The instruction sequence

```
JZ        LABEL1
DEC      A
JZ        LABEL2
```

will change the accumulator to 00<sub>H</sub> and cause program execution to continue at the instruction identified by the label LABEL2.

Operation:     JZ  
                   (PC)    (PC) + 2  
                   if (A) = 0  
                   then (PC)    (PC) + rel

Encoding:      

|         |         |
|---------|---------|
| 0 1 1 0 | 0 0 0 0 |
|---------|---------|

|              |
|--------------|
| rel. address |
|--------------|

Bytes:            2

Cycles:          2

**LCALL    addr16**

Function:        Long call

Description:    LCALL calls a subroutine located at the indicated address. The instruction adds three to the program counter to generate the address of the next instruction and then pushes the 16-bit result onto the stack (low byte first), incrementing the stack pointer by two. The high-order and low-order bytes of the PC are then loaded, respectively, with the second and third bytes of the LCALL instruction. Program execution continues with the instruction at this address. The subroutine may therefore begin anywhere in the full 64-Kbyte program memory address space. No flags are affected.

Example:        Initially the stack pointer equals 07<sub>H</sub>. The label "SUBRTN" is assigned to program memory location 1234<sub>H</sub>. After executing the instruction

LCALL    SUBRTN

at location 0123<sub>H</sub>, the stack pointer will contain 09<sub>H</sub>, internal RAM locations 08<sub>H</sub> and 09<sub>H</sub> will contain 26<sub>H</sub> and 01<sub>H</sub>, and the PC will contain 1234<sub>H</sub>.

Operation:      LCALL  
                   (PC)    (PC) + 3  
                   (SP)    (SP) + 1  
                   ((SP)) (PC7-0)  
                   (SP)    (SP) + 1  
                   ((SP)) (PC15-8)  
                   (PC)    addr15-0

Encoding:        

|         |         |
|---------|---------|
| 0 0 0 1 | 0 0 1 0 |
|---------|---------|

|                  |
|------------------|
| addr15 . . addr8 |
|------------------|

|                 |
|-----------------|
| addr7 . . addr0 |
|-----------------|

Bytes:            3

Cycles:          2

**LJMP      addr16**

Function:      Long jump

Description:    LJMP causes an unconditional branch to the indicated address, by loading the high-order and low-order bytes of the PC (respectively) with the second and third instruction bytes. The destination may therefore be anywhere in the full 64-Kbyte program memory address space. No flags are affected.

Example:        The label “JMPADR” is assigned to the instruction at program memory location 1234<sub>H</sub>. The instruction

LJMP      JMPADR

at location 0123<sub>H</sub> will load the program counter with 1234<sub>H</sub>.

Operation:      LJMP  
                  (PC)    addr15-0

Encoding:      

|         |         |
|---------|---------|
| 0 0 0 0 | 0 0 1 0 |
|---------|---------|

|                    |
|--------------------|
| addr15 . . . addr8 |
|--------------------|

|                   |
|-------------------|
| addr7 . . . addr0 |
|-------------------|

Bytes:            3

Cycles:          2

**MOV <dest-byte>, <src-byte>**

Function: Move byte variable

Description: The byte variable indicated by the second operand is copied into the location specified by the first operand. The source byte is not affected. No other register or flag is affected.

This is by far the most flexible operation. Fifteen combinations of source and destination addressing modes are allowed.

Example: Internal RAM location 30<sub>H</sub> holds 40<sub>H</sub>. The value of RAM location 40<sub>H</sub> is 10<sub>H</sub>. The data present at input port 1 is 11001010<sub>B</sub> (0CA<sub>H</sub>).

```
MOV    R0, #30H           ; R0 <= 30H
MOV    A, @R0             ; A <= 40H
MOV    R1,A               ; R1 <= 40H
MOV    B, @R1             ; B <= 10H
MOV    @R1,P1             ; RAM (40H) <= 0CAH
MOV    P2,P1              ; P2 <= 0CAH
```

leaves the value 30<sub>H</sub> in register 0, 40<sub>H</sub> in both the accumulator and register 1, 10<sub>H</sub> in register B, and 0CA<sub>H</sub> (11001010<sub>B</sub>) both in RAM location 40<sub>H</sub> and output on port 2.

**MOV A,Rn**

Operation: MOV  
(A) (Rn)

Encoding: 

|         |         |
|---------|---------|
| 1 1 1 0 | 1 r r r |
|---------|---------|

Bytes: 1

Cycles: 1

**MOV A,direct \*)**

Operation: MOV  
(A) (direct)

Encoding: 

|         |         |
|---------|---------|
| 1 1 1 0 | 0 1 0 1 |
|---------|---------|

|                |
|----------------|
| direct address |
|----------------|

Bytes: 2

Cycles: 1

\*) MOV A,ACC is not a valid instruction. The content of the accumulator after the execution of this instruction is undefined.

**MOV A,@Ri**

Operation: MOV  
(A) ((Ri))

Encoding: 

|         |         |
|---------|---------|
| 1 1 1 0 | 0 1 1 i |
|---------|---------|

Bytes: 1

Cycles: 1

**MOV A,#data**

Operation: MOV  
(A) #data

Encoding: 

|         |         |
|---------|---------|
| 0 1 1 1 | 0 1 0 0 |
|---------|---------|

|                |
|----------------|
| immediate data |
|----------------|

Bytes: 2

Cycles: 1

**MOV Rn,A**

Operation: MOV  
(Rn) (A)

Encoding: 

|         |         |
|---------|---------|
| 1 1 1 1 | 1 r r r |
|---------|---------|

Bytes: 1

Cycles: 1

**MOV Rn,direct**

Operation: MOV  
(Rn) (direct)

Encoding: 

|         |         |
|---------|---------|
| 1 0 1 0 | 1 r r r |
|---------|---------|

|                |
|----------------|
| direct address |
|----------------|

Bytes: 2

Cycles: 2

**MOV Rn, #data**

Operation: MOV  
(Rn) #data

Encoding: 

|         |         |
|---------|---------|
| 0 1 1 1 | 1 r r r |
|---------|---------|

|                |
|----------------|
| immediate data |
|----------------|

Bytes: 2

Cycles: 1

**MOV direct,A**

Operation: MOV  
(direct) (A)

Encoding: 

|         |         |
|---------|---------|
| 1 1 1 1 | 0 1 0 1 |
|---------|---------|

|                |
|----------------|
| direct address |
|----------------|

Bytes: 2

Cycles: 1

**MOV direct,Rn**

Operation: MOV  
(direct) (Rn)

Encoding: 

|         |         |
|---------|---------|
| 1 0 0 0 | 1 r r r |
|---------|---------|

|                |
|----------------|
| direct address |
|----------------|

Bytes: 2

Cycles: 2

**MOV direct,direct**

Operation: MOV  
(direct) (direct)

Encoding: 

|         |         |
|---------|---------|
| 1 0 0 0 | 0 1 0 1 |
|---------|---------|

|                 |
|-----------------|
| dir.addr. (src) |
|-----------------|

|                  |
|------------------|
| dir.addr. (dest) |
|------------------|

Bytes: 3

Cycles: 2



**MOV direct, @ Ri**

Operation: MOV  
(direct) ((Ri))

Encoding: 

|         |         |
|---------|---------|
| 1 0 0 0 | 0 1 1 i |
|---------|---------|

|                |
|----------------|
| direct address |
|----------------|

Bytes: 2

Cycles: 2

**MOV direct, #data**

Operation: MOV  
(direct) #data

Encoding: 

|         |         |
|---------|---------|
| 0 1 1 1 | 0 1 0 1 |
|---------|---------|

|                |
|----------------|
| direct address |
|----------------|

|                |
|----------------|
| immediate data |
|----------------|

Bytes: 3

Cycles: 2

**MOV @ Ri,A**

Operation: MOV  
((Ri)) (A)

Encoding: 

|         |         |
|---------|---------|
| 1 1 1 1 | 0 1 1 i |
|---------|---------|

Bytes: 1

Cycles: 1

**MOV @ Ri,direct**

Operation: MOV  
((Ri)) (direct)

Encoding: 

|         |         |
|---------|---------|
| 1 0 1 0 | 0 1 1 i |
|---------|---------|

|                |
|----------------|
| direct address |
|----------------|

Bytes: 2

Cycles: 2

**MOV @ Ri,#data**

Operation: MOV  
((Ri)) #data

Encoding: 

|   |   |   |   |   |   |   |   |
|---|---|---|---|---|---|---|---|
| 0 | 1 | 1 | 1 | 0 | 1 | 1 | i |
|---|---|---|---|---|---|---|---|

|                |
|----------------|
| immediate data |
|----------------|

Bytes: 2

Cycles: 1

**MOV <dest-bit>, <src-bit>**

Function: Move bit data

Description: The Boolean variable indicated by the second operand is copied into the location specified by the first operand. One of the operands must be the carry flag; the other may be any directly addressable bit. No other register or flag is affected.

Example: The carry flag is originally set. The data present at input port 3 is 11000101<sub>B</sub>. The data previously written to output port 1 is 35<sub>H</sub> (00110101<sub>B</sub>).

```
MOV P1.3,C
MOV C,P3.3
MOV P1.2,C
```

will leave the carry cleared and change port 1 to 39<sub>H</sub> (00111001<sub>B</sub>).

**MOV C,bit**

Operation: MOV  
(C) (bit)

Encoding: 

|         |         |
|---------|---------|
| 1 0 1 0 | 0 0 1 0 |
|---------|---------|

|             |
|-------------|
| bit address |
|-------------|

Bytes: 2

Cycles: 1

**MOV bit,C**

Operation: MOV  
(bit) (C)

Encoding: 

|         |         |
|---------|---------|
| 1 0 0 1 | 0 0 1 0 |
|---------|---------|

|             |
|-------------|
| bit address |
|-------------|

Bytes: 2

Cycles: 2

**MOV DPTR, #data16**

Function: Load data pointer with a 16-bit constant

Description: The data pointer is loaded with the 16-bit constant indicated. The 16-bit constant is loaded into the second and third bytes of the instruction. The second byte (DPH) is the high-order byte, while the third byte (DPL) holds the low-order byte. No flags are affected.

This is the only instruction that moves 16 bits of data at once.

Example: The instruction

```
MOV DPTR, #1234H
```

will load the value 1234<sub>H</sub> into the data pointer: DPH will hold 12<sub>H</sub> and DPL will hold 34<sub>H</sub>.

Operation: MOV  
(DPTR) #data15-0  
DPH □ DPL #data15-8 □ #data7-0

Encoding: 

|         |         |
|---------|---------|
| 1 0 0 1 | 0 0 0 0 |
|---------|---------|

|                        |
|------------------------|
| immed. data 15 . . . 8 |
|------------------------|

|                       |
|-----------------------|
| immed. data 7 . . . 0 |
|-----------------------|

Bytes: 3

Cycles: 2

**MOVC A, @A + <base-reg>**

Function: Read code byte

Description: Load the accumulator with a code byte, or constant from program memory. The address of the byte fetched is the sum of the original unsigned eight-bit accumulator contents and the contents of a sixteen-bit base register, which may be either the data pointer or the PC. In the latter case, the PC is incremented to the address of the following instruction before being added to the accumulator; otherwise the base register is not altered. Sixteen-bit addition is performed so a carry-out from the low-order eight bits may propagate through higher-order bits. No flags are affected.

Example: A value between 0 and 3 is in the accumulator. The following instructions will translate the value in the accumulator to one of four values defined by the DB (define byte) directive.

```
REL_PC: INC      A
          MOVC   A, @A + PC
          RET
          DB     66H
          DB     77H
          DB     88H
          DB     99H
```

If the subroutine is called with the accumulator equal to 01<sub>H</sub>, it will return with 77<sub>H</sub> in the accumulator. The INC A before the MOVC instruction is needed to “get around” the RET instruction above the table. If several bytes of code separated the MOVC from the table, the corresponding number would be added to the accumulator instead.

**MOVC A, @A + DPTR**

Operation: MOVC  
(A) ((A) + (DPTR))

Encoding: 

|         |         |
|---------|---------|
| 1 0 0 1 | 0 0 1 1 |
|---------|---------|

Bytes: 1

Cycles: 2

**MOVC    A, @A + PC**

Operation:    MOVC  
                  (PC) (PC) + 1  
                  (A)  ((A) + (PC))

Encoding:    

|         |         |
|---------|---------|
| 1 0 0 0 | 0 0 1 1 |
|---------|---------|

Bytes:        1

Cycles:      2

**MOVC    @(DPTR++), A**

Function:        Write code byte

Description:    Store the byte content of accumulator to program memory. The address in program memory is pointed to by the data pointer. The data pointer is incremented by hardware, after the write. No flags are affected.

Example:        Store value E4<sub>H</sub> to program memory at 1000<sub>H</sub>. Opcode E4<sub>H</sub> is the CLR A instruction.

```
MOV    A, #E4H
MOV    DPTR,#1000H
MOVC   @(DPTR++), A                    ; write CLR A to program memory at 1000H
```

Operation:      MOVC  
                   ((DPTR)) (A)  
                   (DPTR) = (DPTR) + 1

Encoding:      

|         |         |
|---------|---------|
| 1 0 1 0 | 0 1 0 1 |
|---------|---------|

Bytes:            1

Cycles:           2

*Note: This instruction is XC800-specific, therefore may not be supported by standard 8051 assembler. In such cases, this can be workaround by direct byte declaration and definition e.g. ".byte #A5<sub>H</sub>" (syntax is assembler dependent).*

*Note: This instruction shares the same opcode with another XC800-specific instruction TRAP. MOVC is selected only if EO.TRAP\_EN = 0.*

**MOVX** <dest-byte>, <src-byte>

Function: Move external

Description: The MOVX instructions transfer data between the accumulator and a byte of external data memory, hence the "X" appended to MOV. There are two types of instructions, differing in whether they provide an 8-bit or 16-bit indirect address to the external data RAM.

In the first type, the contents of R0 or R1 in the current register bank provide an 8-bit address on the low-byte address port. Eight bits are sufficient for external I/O expansion decoding or a relatively small RAM array. For somewhat larger arrays, any output port pins can be used to output higher-order address bits. These pins would be controlled by an output instruction preceding the MOVX.

In the second type of MOVX instructions, the data pointer generates a 16-bit address. The high-byte address port outputs the high-order eight address bits (the contents of DPH) while the low-byte address port outputs the low-order eight address bits (DPL). The special function registers of the address ports are unaffected and retain the previous contents. This form of access is faster and more efficient when accessing very large data arrays (up to 64 Kbytes), since no additional instructions are needed to set up the output ports.

It is possible in some situations to mix the two MOVX types. A large RAM array with its high-order address lines driven on the address port can be addressed via the data pointer, or with code to output high-order address bits to the high-byte port followed by a MOVX instruction using R0 or R1.

Example: An external 256-byte RAM using multiplexed address/data lines is connected to the low-byte address port. Port 3 provides control lines for the external RAM. Other ports (such as the high-byte address port) are used for normal I/O. Registers 0 and 1 contain 12<sub>H</sub> and 34<sub>H</sub>. Location 34<sub>H</sub> of the external RAM holds the value 56<sub>H</sub>. The instruction sequence

```
MOVX  A, @R1
MOVX  @R0,A
```

copies the value 56<sub>H</sub> into both the accumulator and external RAM location 12<sub>H</sub>.



**MOVX A,@Ri**

Operation: MOVX  
(A) ((Ri))

Encoding: 

|         |         |
|---------|---------|
| 1 1 1 0 | 0 0 1 i |
|---------|---------|

Bytes: 1

Cycles: 2

**MOVX A,@DPTR**

Operation: MOVX  
(A) ((DPTR))

Encoding: 

|         |         |
|---------|---------|
| 1 1 1 0 | 0 0 0 0 |
|---------|---------|

Bytes: 1

Cycles: 2

**MOVX @Ri,A**

Operation: MOVX  
((Ri)) (A)

Encoding: 

|         |         |
|---------|---------|
| 1 1 1 1 | 0 0 1 i |
|---------|---------|

Bytes: 1

Cycles: 2

**MOVX @DPTR,A**

Operation: MOVX  
((DPTR)) (A)

Encoding: 

|         |         |
|---------|---------|
| 1 1 1 1 | 0 0 0 0 |
|---------|---------|

Bytes: 1

Cycles: 2

**MUL AB**

Function: Multiply

Description: MUL AB multiplies the unsigned eight-bit integers in the accumulator and register B. The low-order byte of the sixteen-bit product is left in the accumulator, and the high-order byte in B. If the product is greater than 255 (0FF<sub>H</sub>) the overflow flag is set; otherwise it is cleared. The carry flag is always cleared.

Example: Originally the accumulator holds the value 80 (50<sub>H</sub>). Register B holds the value 160 (0A0<sub>H</sub>). The instruction

MUL AB

will give the product 12,800 (3200<sub>H</sub>), so B is changed to 32<sub>H</sub> (00110010<sub>B</sub>) and the accumulator is cleared. The overflow flag is set, carry is cleared.

Operation: MUL

(A7-0) (A) x (B)  
(B15-8)

Encoding:

|         |         |
|---------|---------|
| 1 0 1 0 | 0 1 0 0 |
|---------|---------|

Bytes: 1

Cycles: 4

**NOP**

Function: No operation

Description: Execution continues at the following instruction. Other than the PC, no registers or flags are affected.

Example: It is desired to produce a low-going output pulse on bit 7 of port 2 lasting exactly 5 cycles. A simple SETB/CLR sequence would generate a one-cycle pulse, so four additional cycles must be inserted. This may be done (assuming no interrupts are enabled) with the instruction sequence

```
CLR P2.7
NOP
NOP
NOP
NOP
SETB P2.7
```

Operation: NOP

Encoding: 

|   |   |   |   |   |   |   |   |
|---|---|---|---|---|---|---|---|
| 0 | 0 | 0 | 0 | 0 | 0 | 0 | 0 |
|---|---|---|---|---|---|---|---|

Bytes: 1

Cycles: 1

**ORL      <dest-byte>, <src-byte>**

Function:      Logical OR for byte variables

Description:    ORL performs the bitwise logical OR operation between the indicated variables, storing the results in the destination byte. No flags are affected (except P, if <dest-byte> = A).

The two operands allow six addressing mode combinations. When the destination is the accumulator, the source can use register, direct, register-indirect, or immediate addressing; when the destination is a direct address, the source can be the accumulator or immediate data.

**Note:**

When this instruction is used to modify an output port, the value used as the original port data will be read from the output data latch, *not* the input pins.

Example:      If the accumulator holds 0C3<sub>H</sub> (11000011<sub>B</sub>) and R0 holds 55<sub>H</sub> (01010101<sub>B</sub>) then the instruction

ORL      A,R0

will leave the accumulator holding the value 0D7<sub>H</sub> (11010111<sub>B</sub>).

When the destination is a directly addressed byte, the instruction can set combinations of bits in any RAM location or hardware register. The pattern of bits to be set is determined by a mask byte, which may be either a constant data value in the instruction or a variable computed in the accumulator at run-time. The instruction

ORL      P1,#00110010<sub>B</sub>

will set bits 5, 4, and 1 of output port 1.

**ORL      A,Rn**

Operation:      ORL  
                  (A) (A)    (Rn)

Encoding:      

|         |         |
|---------|---------|
| 0 1 0 0 | 1 r r r |
|---------|---------|

Bytes:          1

Cycles:         1

**ORL A,direct**

Operation: ORL  
(A) (A) (direct)

Encoding: 

|         |         |
|---------|---------|
| 0 1 0 0 | 0 1 0 1 |
|---------|---------|

|                |
|----------------|
| direct address |
|----------------|

Bytes: 2

Cycles: 1

**ORL A,@Ri**

Operation: ORL  
(A) (A) ((Ri))

Encoding: 

|         |         |
|---------|---------|
| 0 1 0 0 | 0 1 1 i |
|---------|---------|

Bytes: 1

Cycles: 1

**ORL A,#data**

Operation: ORL  
(A) (A) #data

Encoding: 

|         |         |
|---------|---------|
| 0 1 0 0 | 0 1 0 0 |
|---------|---------|

|                |
|----------------|
| immediate data |
|----------------|

Bytes: 2

Cycles: 1

**ORL direct,A**

Operation: ORL  
(direct) (direct) (A)

Encoding: 

|         |         |
|---------|---------|
| 0 1 0 0 | 0 0 1 0 |
|---------|---------|

|                |
|----------------|
| direct address |
|----------------|

Bytes: 2

Cycles: 1

**ORL      direct, #data**

Operation:    ORL  
                 (direct) (direct) #data

Encoding:    

|   |   |   |   |   |   |   |   |
|---|---|---|---|---|---|---|---|
| 0 | 1 | 0 | 0 | 0 | 0 | 1 | 1 |
|---|---|---|---|---|---|---|---|

|                |
|----------------|
| direct address |
|----------------|

|                |
|----------------|
| immediate data |
|----------------|

Bytes:        3

Cycles:      2

**ORL C, <src-bit>**

Function: Logical OR for bit variables

Description: Set the carry flag if the Boolean value is a logic 1; leave the carry in its current state otherwise. A slash (“/”) preceding the operand in the assembly language indicates that the logical complement of the addressed bit is used as the source value, but the source bit itself is not affected. No other flags are affected.

Example: Set the carry flag if, and only if, P1.0 = 1, ACC.7 = 1, or OV = 0:

```
MOV    C,P1.0           ; Load carry with input pin P1.0
ORL    C,ACC.7          ; OR carry with the accumulator bit 7
ORL    C,/OV            ; OR carry with the inverse of OV
```

**ORL C,bit**

Operation: ORL  
(C) (C) (bit)

Encoding: 

|         |         |
|---------|---------|
| 0 1 1 1 | 0 0 1 0 |
|---------|---------|

|             |
|-------------|
| bit address |
|-------------|

Bytes: 2

Cycles: 2

**ORL C,/bit**

Operation: ORL  
(C) (C) / (bit)

Encoding: 

|         |         |
|---------|---------|
| 1 0 1 0 | 0 0 0 0 |
|---------|---------|

|             |
|-------------|
| bit address |
|-------------|

Bytes: 2

Cycles: 2

**POP      direct**

Function:      Pop from stack

Description:    The contents of the internal RAM location addressed by the stack pointer is read, and the stack pointer is decremented by one. The value read is the transfer to the directly addressed byte indicated. No flags are affected.

Example:        The stack pointer originally contains the value 32<sub>H</sub>, and internal RAM locations 30<sub>H</sub> through 32<sub>H</sub> contain the values 20<sub>H</sub>, 23<sub>H</sub>, and 01<sub>H</sub>, respectively. The instruction sequence

```
POP     DPH
POP     DPL
```

will leave the stack pointer equal to the value 30<sub>H</sub> and the data pointer set to 0123<sub>H</sub>. At this point the instruction

```
POP     SP
```

will leave the stack pointer set to 20<sub>H</sub>. Note that in this special case the stack pointer was decremented to 2F<sub>H</sub> before being loaded with the value popped (20<sub>H</sub>).

Operation:      POP  
                   (direct) ((SP))  
                   (SP) (SP) – 1

Encoding:      

|         |         |
|---------|---------|
| 1 1 0 1 | 0 0 0 0 |
|---------|---------|

|                |
|----------------|
| direct address |
|----------------|

Bytes:          2

Cycles:         2



**PUSH     direct**

Function:     Push onto stack

Description:   The stack pointer is incremented by one. The content of the indicated variable is then copied into the internal RAM location addressed by the stack pointer. Otherwise no flags are affected.

Example:       On entering an interrupt routine the stack pointer contains 09<sub>H</sub>. The data pointer holds the value 0123<sub>H</sub>. The instruction sequence

```
PUSH   DPL
PUSH   DPH
```

will leave the stack pointer set to 0B<sub>H</sub> and store 23<sub>H</sub> and 01<sub>H</sub> in internal RAM locations 0A<sub>H</sub> and 0B<sub>H</sub>, respectively.

Operation:     PUSH  
                   (SP)   (SP) + 1  
                   ((SP))   direct

Encoding:     

|         |         |
|---------|---------|
| 1 1 0 0 | 0 0 0 0 |
|---------|---------|

|                |
|----------------|
| direct address |
|----------------|

Bytes:        2

Cycles:       2

**RET**

Function: Return from subroutine

Description: RET pops the high and low-order bytes of the PC successively from the stack, decrementing the stack pointer by two. Program execution continues at the resulting address, generally the instruction immediately following an ACALL or LCALL. No flags are affected.

Example: The stack pointer originally contains the value 0B<sub>H</sub>. Internal RAM locations 0A<sub>H</sub> and 0B<sub>H</sub> contain the values 23<sub>H</sub> and 01<sub>H</sub>, respectively. The instruction  
RET  
will leave the stack pointer equal to the value 09<sub>H</sub>. Program execution will continue at location 0123<sub>H</sub>.

Operation: RET  
(PC15-8) ((SP))  
(SP) (SP) – 1  
(PC7-0) ((SP))  
(SP) (SP) – 1

Encoding: 

|   |   |   |   |   |   |   |   |
|---|---|---|---|---|---|---|---|
| 0 | 0 | 1 | 0 | 0 | 0 | 1 | 0 |
|---|---|---|---|---|---|---|---|

Bytes: 1

Cycles: 2

**RETI**

Function: Return from interrupt

Description: RETI pops the high and low-order bytes of the PC successively from the stack, and restores the interrupt logic to accept additional interrupts at the same priority level as the one just processed. The stack pointer is left decremented by two. No other registers are affected; the PSW is *not* automatically restored to its pre-interrupt status. Program execution continues at the resulting address, which is generally the instruction immediately after the point at which the interrupt request was detected. If a lower or same-level interrupt is pending when the RETI instruction is executed, that one instruction will be executed before the pending interrupt is processed.

Example: The stack pointer originally contains the value 0B<sub>H</sub>. An interrupt was detected during the instruction ending at location 0122<sub>H</sub>. Internal RAM locations 0A<sub>H</sub> and 0B<sub>H</sub> contain the values 23<sub>H</sub> and 01<sub>H</sub>, respectively. The instruction  
 RETI  
 will leave the stack pointer equal to 09<sub>H</sub> and return program execution to location 0123<sub>H</sub>.

Operation: RETI  
 (PC15-8) ((SP))  
 (SP) (SP) – 1  
 (PC7-0) ((SP))  
 (SP) (SP) – 1

Encoding: 

|   |   |   |   |   |   |   |   |
|---|---|---|---|---|---|---|---|
| 0 | 0 | 1 | 1 | 0 | 0 | 1 | 0 |
|---|---|---|---|---|---|---|---|

Bytes: 1

Cycles: 2

**RL      A**

Function:      Rotate accumulator left

Description:    The eight bits in the accumulator are rotated one bit to the left. Bit 7 is rotated into the bit 0 position. No flags are affected.

Example:        The accumulator holds the value 0C5<sub>H</sub> (11000101<sub>B</sub>). The instruction  
                     RL    A  
                     leaves the accumulator holding the value 8B<sub>H</sub> (10001011<sub>B</sub>) with the carry  
                     unaffected.

Operation:      RL  
                     (A<sub>n+1</sub>) (A<sub>n</sub>) n = 0-6  
                     (A<sub>0</sub>) (A<sub>7</sub>)

Encoding:       

|         |         |
|---------|---------|
| 0 0 1 0 | 0 0 1 1 |
|---------|---------|

Bytes:            1

Cycles:           1

**RLC      A**

Function:      Rotate accumulator left through carry flag

Description:    The eight bits in the accumulator and the carry flag are together rotated one bit to the left. Bit 7 moves into the carry flag; the original state of the carry flag moves into the bit 0 position. No other flags are affected.

Example:        The accumulator holds the value 0C5<sub>H</sub> (11000101<sub>B</sub>), and the carry is zero. The instruction

RLC      A

leaves the accumulator holding the value 8A<sub>H</sub> (10001010<sub>B</sub>) with the carry set.

Operation:     RLC  
                    $(A_{n+1}) \ (A_n) \ n = 0-6$   
                   (A0) (C)  
                   (C) (A7)

Encoding:      

|         |         |
|---------|---------|
| 0 0 1 1 | 0 0 1 1 |
|---------|---------|

Bytes:          1

Cycles:         1

**RR      A**

Function:      Rotate accumulator right

Description:    The eight bits in the accumulator are rotated one bit to the right. Bit 0 is rotated into the bit 7 position. No flags are affected.

Example:        The accumulator holds the value 0C5<sub>H</sub> (11000101<sub>B</sub>). The instruction  
                     RR    A  
                     leaves the accumulator holding the value 0E2<sub>H</sub> (11100010<sub>B</sub>) with the carry  
                     unaffected.

Operation:      RR  
                     (An) (An + 1) n = 0-6  
                     (A7) (A0)

Encoding:      

|         |         |
|---------|---------|
| 0 0 0 0 | 0 0 1 1 |
|---------|---------|

Bytes:          1

Cycles:         1

**RRC     A**

Function:     Rotate accumulator right through carry flag

Description:   The eight bits in the accumulator and the carry flag are together rotated one bit to the right. Bit 0 moves into the carry flag; the original value of the carry flag moves into the bit 7 position. No other flags are affected.

Example:     The accumulator holds the value 0C5<sub>H</sub> (11000101<sub>B</sub>), the carry is zero. The instruction

RRC     A

leaves the accumulator holding the value 62<sub>H</sub> (01100010<sub>B</sub>) with the carry set.

Operation:   RRC  
               (A<sub>n</sub>)   (A<sub>n + 1</sub>) n=0-6  
               (A<sub>7</sub>)   (C)  
               (C)    (A<sub>0</sub>)

Encoding:   

|         |         |
|---------|---------|
| 0 0 0 1 | 0 0 1 1 |
|---------|---------|

Bytes:       1

Cycles:      1

**SETB <bit>**

Function: Set bit

Description: SETB sets the indicated bit to one. SETB can operate on the carry flag or any directly addressable bit. No other flags are affected.

Example: The carry flag is cleared. Output port 1 has been written with the value 34<sub>H</sub> (00110100<sub>B</sub>). The instructions

```
SETB C
SETB P1.0
```

will leave the carry flag set to 1 and change the data output on port 1 to 35<sub>H</sub> (00110101<sub>B</sub>).

**SETB C**

Operation: SETB  
(C) 1

Encoding: 

|   |   |   |   |   |   |   |   |
|---|---|---|---|---|---|---|---|
| 1 | 1 | 0 | 1 | 0 | 0 | 1 | 1 |
|---|---|---|---|---|---|---|---|

Bytes: 1

Cycles: 1

**SETB bit**

Operation: SETB  
(bit) 1

Encoding: 

|   |   |   |   |   |   |   |   |
|---|---|---|---|---|---|---|---|
| 1 | 1 | 0 | 1 | 0 | 0 | 1 | 0 |
|---|---|---|---|---|---|---|---|

|             |
|-------------|
| bit address |
|-------------|

Bytes: 2

Cycles: 1



**SJMP rel**

Function: Short jump

Description: Program control branches unconditionally to the address indicated. The branch destination is computed by adding the signed displacement in the second instruction byte to the PC, after incrementing the PC twice. Therefore, the range of destinations allowed is from 128 bytes preceding this instruction to 127 bytes following it.

Example: The label "RELADR" is assigned to an instruction at program memory location 0123<sub>H</sub>. The instruction

```
SJMP RELADR
```

will assemble into location 0100<sub>H</sub>. After the instruction is executed, the PC will contain the value 0123<sub>H</sub>.

**Note:**

Under the above conditions the instruction following SJMP will be at 102<sub>H</sub>. Therefore, the displacement byte of the instruction will be the relative offset (0123<sub>H</sub>-0102<sub>H</sub>) = 21<sub>H</sub>. In other words, an SJMP with a displacement of 0FE<sub>H</sub> would be a one-instruction infinite loop.

Operation: SJMP  
(PC) (PC) + 2  
(PC) (PC) + rel

Encoding: 

|         |         |
|---------|---------|
| 1 0 0 0 | 0 0 0 0 |
|---------|---------|

|              |
|--------------|
| rel. address |
|--------------|

Bytes: 2

Cycles: 2

**SUBB A, <src-byte>**

Function: Subtract with borrow

Description: SUBB subtracts the indicated variable and the carry flag together from the accumulator, leaving the result in the accumulator. SUBB sets the carry (borrow) flag if a borrow is needed for bit 7, and clears C otherwise. (If C was set *before* executing a SUBB instruction, this indicates that a borrow was needed for the previous step in a multiple precision subtraction, so the carry is subtracted from the accumulator along with the source operand). AC is set if a borrow is needed for bit 3, and cleared otherwise. OV is set if a borrow is needed into bit 6 but not into bit 7, or into bit 7 but not bit 6.

When subtracting signed integers OV indicates a negative number produced when a negative value is subtracted from a positive value, or a positive result when a positive number is subtracted from a negative number.

The source operand allows four addressing modes: register, direct, register-indirect, or immediate.

Example: The accumulator holds 0C9<sub>H</sub> (11001001<sub>B</sub>), register 2 holds 54<sub>H</sub> (01010100<sub>B</sub>), and the carry flag is set. The instruction

SUBB A,R2

will leave the value 74<sub>H</sub> (01110100<sub>B</sub>) in the accumulator, with the carry flag and AC cleared but OV set.

Notice that 0C9<sub>H</sub> minus 54<sub>H</sub> is 75<sub>H</sub>. The difference between this and the above result is due to the (borrow) flag being set before the operation. If the state of the carry is not known before starting a single or multiple-precision subtraction, it should be explicitly cleared by a CLR C instruction.

**SUBB A,Rn**

Operation: SUBB  
(A) (A) – (C) – (Rn)

Encoding: 

|         |         |
|---------|---------|
| 1 0 0 1 | 1 r r r |
|---------|---------|

Bytes: 1

Cycles: 1

**SUBB A,direct**

Operation: SUBB  
 (A) (A) – (C) – (direct)

Encoding: 

|         |         |
|---------|---------|
| 1 0 0 1 | 0 1 0 1 |
|---------|---------|

|                |
|----------------|
| direct address |
|----------------|

Bytes: 2  
 Cycles: 1

**SUBB A, @ Ri**

Operation: SUBB  
 (A) (A) – (C) – ((Ri))

Encoding: 

|         |         |
|---------|---------|
| 1 0 0 1 | 0 1 1 i |
|---------|---------|

Bytes: 1  
 Cycles: 1

**SUBB A, #data**

Operation: SUBB  
 (A) (A) – (C) – #data

Encoding: 

|         |         |
|---------|---------|
| 1 0 0 1 | 0 1 0 0 |
|---------|---------|

|                |
|----------------|
| immediate data |
|----------------|

Bytes: 2  
 Cycles: 1

**SWAP A**

Function: Swap nibbles within the accumulator

Description: SWAP A interchanges the low and high-order nibbles (four-bit fields) of the accumulator (bits 3-0 and bits 7-4). The operation can also be thought of as a four-bit rotate instruction. No flags are affected.

Example: The accumulator holds the value 0C5<sub>H</sub> (11000101<sub>B</sub>). The instruction  
 SWAP A  
 leaves the accumulator holding the value 5C<sub>H</sub> (01011100<sub>B</sub>).

Operation: SWAP  
 (A3-0) (A7-4), (A7-4) (A3-0)

Encoding: 

|         |         |
|---------|---------|
| 1 1 0 0 | 0 1 0 0 |
|---------|---------|

Bytes: 1

Cycles: 1

**TRAP**

Function: Software Break

Description: Assert a software break. Enters debug mode at the end of phase 1 of the machine cycle. No flags are affected.

Example: If EO.TRAP\_EN = 1, opcode A5<sub>H</sub> is a TRAP instruction.

```
MOV    A, #55H
TRAP                      ; break
INC    A
```

Operation: TRAP

Encoding: 

|         |         |
|---------|---------|
| 1 0 1 0 | 0 1 0 1 |
|---------|---------|

Bytes: 1

Cycles: 1

*Note: This instruction is XC800-specific, therefore may not be supported by standard 8051 assembler. In such cases, this can be workaround by direct byte declaration and definition e.g. ".byte #A5<sub>H</sub>" (syntax is assembler dependent).*

*Note: This instruction shares the same opcode with another XC800-specific instruction MOVC @(DPTR++),A. TRAP is selected only if EO.TRAP\_EN = 1.*

**XCH      A, <byte>**

Function:      Exchange accumulator with byte variable

Description:    XCH loads the accumulator with the contents of the indicated variable, at the same time writing the original accumulator contents to the indicated variable. The source/destination operand can use register, direct, or register-indirect addressing.

Example:        R0 contains the address 20<sub>H</sub>. The accumulator holds the value 3F<sub>H</sub> (00111111<sub>B</sub>). Internal RAM location 20<sub>H</sub> holds the value 75<sub>H</sub> (01110101<sub>B</sub>). The instruction

XCH      A, @R0

will leave RAM location 20<sub>H</sub> holding the value 3F<sub>H</sub> (00111111<sub>B</sub>) and 75<sub>H</sub> (01110101<sub>B</sub>) in the accumulator.

**XCH      A,Rn**

Operation:      XCH  
                  (A)    (Rn)

Encoding:      

|         |         |
|---------|---------|
| 1 1 0 0 | 1 r r r |
|---------|---------|

Bytes:            1

Cycles:          1

**XCH      A,direct**

Operation:      XCH  
                  (A)    (direct)

Encoding:      

|         |         |
|---------|---------|
| 1 1 0 0 | 0 1 0 1 |
|---------|---------|

|                |
|----------------|
| direct address |
|----------------|

Bytes:            2

Cycles:          1

**XCH      A, @ Ri**

Operation:    XCH  
                  (A)    ((Ri))

Encoding:    

|   |   |   |   |   |   |   |   |
|---|---|---|---|---|---|---|---|
| 1 | 1 | 0 | 0 | 0 | 1 | 1 | i |
|---|---|---|---|---|---|---|---|

Bytes:        1

Cycles:       1

**XCHD    A,@Ri**

Function:        Exchange digit

Description:    XCHD exchanges the low-order nibble of the accumulator (bits 3-0, generally representing a hexadecimal or BCD digit), with that of the internal RAM location indirectly addressed by the specified register. The high-order nibbles (bits 7-4) of each register are not affected. No flags are affected.

Example:        R0 contains the address 20<sub>H</sub>. The accumulator holds the value 36<sub>H</sub> (00110110<sub>B</sub>). Internal RAM location 20<sub>H</sub> holds the value 75<sub>H</sub> (01110101<sub>B</sub>). The instruction

XCHD    A, @ R0

will leave RAM location 20<sub>H</sub> holding the value 76<sub>H</sub> (01110110<sub>B</sub>) and 35<sub>H</sub> (00110101<sub>B</sub>) in the accumulator.

Operation:      XCHD  
                   (A3-0)    ((Ri)3-0)

Encoding:      

|   |   |   |   |   |   |   |   |
|---|---|---|---|---|---|---|---|
| 1 | 1 | 0 | 1 | 0 | 1 | 1 | i |
|---|---|---|---|---|---|---|---|

Bytes:            1

Cycles:          1



**XRL      <dest-byte>, <src-byte>**

Function:      Logical Exclusive OR for byte variables

Description:    XRL performs the bitwise logical Exclusive OR operation between the indicated variables, storing the results in the destination. No flags are affected (except P, if <dest-byte> = A).

The two operands allow six addressing mode combinations. When the destination is the accumulator, the source can use register, direct, register-indirect, or immediate addressing; when the destination is a direct address, the source can be accumulator or immediate data.

**Note:**

When this instruction is used to modify an output port, the value used as the original port data will be read from the output data latch, *not* the input pins.

Example:      If the accumulator holds 0C3<sub>H</sub> (11000011<sub>B</sub>) and register 0 holds 0AA<sub>H</sub> (10101010<sub>B</sub>) then the instruction

XRL      A,R0

will leave the accumulator holding the value 69<sub>H</sub> (01101001<sub>B</sub>).

When the destination is a directly addressed byte, this instruction can complement combinations of bits in any RAM location or hardware register. The pattern of bits to be complemented is then determined by a mask byte, either a constant contained in the instruction or a variable computed in the accumulator at run-time. The instruction

XRL      P1,#00110001B

will complement bits 5, 4, and 0 of output port 1.

**XRL      A,Rn**

Operation:      XRL2  
                   (A)    (A) ∨ (Rn)

Encoding:      

|         |         |
|---------|---------|
| 0 1 1 0 | 1 r r r |
|---------|---------|

Bytes:          1

Cycles:        1

**XRL A,direct**

Operation: XRL  
 (A) (A) ∨ (direct)

Encoding: 

|         |         |
|---------|---------|
| 0 1 1 0 | 0 1 0 1 |
|---------|---------|

|                |
|----------------|
| direct address |
|----------------|

Bytes: 2

Cycles: 1

**XRL A, @ Ri**

Operation: XRL  
 (A) (A) ∨ ((Ri))

Encoding: 

|         |         |
|---------|---------|
| 0 1 1 0 | 0 1 1 i |
|---------|---------|

Bytes: 1

Cycles: 1

**XRL A, #data**

Operation: XRL  
 (A) (A) ∨ #data

Encoding: 

|         |         |
|---------|---------|
| 0 1 1 0 | 0 1 0 0 |
|---------|---------|

|                |
|----------------|
| immediate data |
|----------------|

Bytes: 2

Cycles: 1

**XRL direct,A**

Operation: XRL  
 (direct) (direct) ∨ (A)

Encoding: 

|         |         |
|---------|---------|
| 0 1 1 0 | 0 0 1 0 |
|---------|---------|

|                |
|----------------|
| direct address |
|----------------|

Bytes: 2

Cycles: 1

**XRL      direct, #data**

Operation:    XRL  
                   (direct) (direct) ∨ #data

Encoding:    

|   |   |   |   |   |   |   |   |
|---|---|---|---|---|---|---|---|
| 0 | 1 | 1 | 0 | 0 | 0 | 1 | 1 |
|---|---|---|---|---|---|---|---|

direct address
immediate data

Bytes:        3

Cycles:      2

[www.infineon.com](http://www.infineon.com)

Published by Infineon Technologies AG