

ABSOLUTE PRESSURE TRANSMITTER

DATA SHEET

FKA...5

The FCX-AIII absolute pressure transmitter accurately measures absolute pressure and transmits a proportional 4 to 20mA signal.

The transmitter utilizes a unique micromachined capacitance silicon sensor with state-of-the-art microprocessor technology to provide exceptional performance and functionality.

FEATURES

1. High accuracy

0.2% accuracy for all calibrated spans is a standard feature for all AP models covering 1.6kPa {0.016bar} range to 3000kPa {30bar} high pressure range. 0.1% accuracy is available as option. Fuji's micro-capacitance silicon sensor assures this accuracy for all suppressed calibration ranges without additional adjustment.

2. Minimum environmental influence

The "Advanced Floating Cell" design which protects the pressure sensor against changes in temperature, and overpressure substantially reduces total measurement error in actual field applications.

3. Fuji/HART® bilingual communications protocol

FCX-AIII series transmitter offers bilingual communications to speak both Fuji proprietary protocol and HART®. Any HART® compatible devices can communicate with FCX-AIII.

4. Application flexibility

Various options that render the FCX-AIII suitable for almost any process applications include:

- Full range of hazardous area approvals
- Built-in RFI filter and lightning arrester
- 5-digit LCD meter with engineering unit
- Stainless steel electronics housing
- Wide selection of materials

5. Burnout current flexibility (Under Scale: 3.2 to 4.0mA, Over Scale: 20.0 to 22.5mA)

Burnout signal level is adjustable using Model FXW Hand Held Communicator (HHC) to comply with NAMUR NE43.

6. Dry calibration without reference pressure

Thanks to the best combination of unique construction of mechanical parts (Sensor unit) and high performance electronics circuit (Electronics unit), reliability of dry calibration without reference pressure is at equal level as wet calibration.



[L-Type]



[T-Type]

SPECIFICATIONS

Functional specifications

Service: Liquid, gas, or vapour

Span, range, and overrange limit:

Type	Span limit [kPa abs] [bar abs]		Range limit [kPa abs] [bar abs]	Overrange limit [MPa] [bar]
	Min.	Max.		
FKA□01	1.6 {0.016}	16 {0.16}	0 to +16 {0 to +0.16}	0.5 {5}
FKA□02	1.6 {0.016}	130 {1.3}	0 to +130 {0 to +1.3}	0.5 {5}
FKA□03	5 {0.05}	500 {5}	0 to +500 {0 to +5}	1.5 {15}
FKA□04	30 {0.3}	3000 {30}	0 to +3000 {0 to +30}	9 {90}

Remark: To minimize environmental influence, span should be greater than 1/40 of the max. span in most applications.

- The maximum span of each sensor can be converted to different units using factors as below.

1MPa abs=10³kPa abs=10bar abs=10.19716kgf/cm² abs
=145.0377psi abs

1kPa abs =10mbar abs=101.9716mmH₂O abs
=4.01463inH₂O abs=7.50062mmHg abs

Output signal: 4 to 20mA DC with digital signal superimposed on the 4 to 20mA signal.

Power supply: Transmitter operates on 10.5V to 45V DC at transmitter terminals.
10.5V to 32V DC for the units with optional arrester.

Load limitations: see figure below

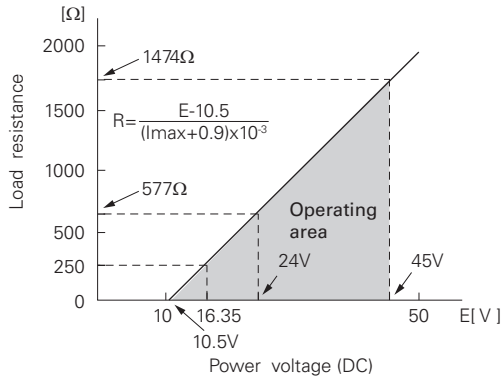

Note: For communication with HHC⁽¹⁾ (Model: FXW), min. of 250Ω is required.

Hazardous locations: SEE TABLE2

Zero/span adjustment:

Zero and span are adjustable from the HHC⁽¹⁾. Zero and span are also adjustable externally from the adjustment screw.

Damping:

Adjustable from HHC or local configurator unit with LCD display. The time constant is adjustable between 0.06 to 32 seconds.

Zero elevation/suppression:

Zero can be elevated within the specified range limit of each sensor model.

Normal/reverse action:

Selectable from HHC⁽¹⁾.

Indication:

Analog indicator or 5-digit LCD meter, as specified.

Burnout direction: Selectable from HHC⁽¹⁾

If self-diagnostic detect transmitter failure, the analog signal will be driven to either "Output Hold", "Output Overscale" or "Output Underscale" modes.

"Output Hold":

Output signal is hold as the value just before failure happens.

"Output Overscale":

Adjustable within the range 20.0mA to 22.5mA from HHC⁽¹⁾

"Output Underscale":

Adjustable within the range 3.2mA to 4.0mA from HHC⁽¹⁾

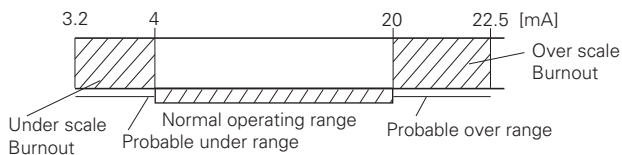

Output Limits conforming the NAMUR NE43 by order.

Loop-check output:

Transmitter can be configured to provide constant signal 3.2mA through 22.5mA by HHC⁽¹⁾.

Temperature limit:

Ambient: -40 to +85°C

(-20 to +80°C for LCD indicator)

(-40 to +60°C for arrester option)

For explosionproof units (flameproof or intrinsic safety), ambient temperature must be within the limits specified by each standard.

Process: -40 to +85°C for silicone fill sensor

Storage: -40 to +90°C

Humidity limit: 0 to 100% RH

Communication: With HHC⁽¹⁾ (Model FXW, consult Data Sheet No. EDS8-47), following items can be remotely displayed or configured.

Note: HHC's version must be higher than 7.0 (or FXW □□□□1-□4), for FCX-AIII.

Local configurator with LCD display (option):

Local configurator with 3 push button and LCD display can support following items.

Items	By communication with FXW		By local configurator (with 3 push button)	
	Display	Set	Display	Set
Tag No.	✓	✓	✓	✓
Model No.	✓	✓	✓	✓
Serial No. & Software Version	✓	—	✓	—
Engineering unit	✓	✓	✓	✓
Range limit	✓	—	✓	—
Measuring range	✓	✓	✓	✓
Damping	✓	✓	✓	✓
Output mode	✓	—	✓	—
Burnout direction	✓	✓	✓	✓
Calibration	✓	✓	✓	✓
Output adjust	—	✓	—	✓
Data	✓	—	✓	—
Self diagnoses	✓	—	✓	—
Printer (In case of FXW with printer option)	✓	—	—	—
External switch lock	✓	✓	✓	✓
Transmitter display	✓	✓	✓	✓
Linearize	✓	✓	—	—
Rerange	✓	✓	✓	✓
Saturate current	✓	✓	✓	✓
Write protect	✓	✓	✓	✓
History				
- Calibration history	✓	✓	✓	✓
- Ambient temperature history	✓	—	✓	—

EMC Conformity: EN61326-1: 2006 CE

(Note) (1) HHC: Hand Held Communicator

Performance specifications

Reference conditions, silicone oil fill, 316SS isolating diaphragms, 4 to 20mA analog output in linear mode.

Accuracy rating: (including linearity, hysteresis, and repeatability).

(Standard)

For spans greater than 1/10 of URL: $\pm 0.2\%$ of span

For spans below 1/10 of URL:

$$\pm \left(0.1 + 0.1 \frac{0.1 \times \text{URL}}{\text{Span}} \right) \% \text{ of span}$$

(Option) (code: 21th digit H)

(Not available for Max span 16kPa abs, 130kPa abs)

For spans greater than 1/10 of URL: $\pm 0.1\%$ of span

For spans below 1/10 of URL:

$$\pm \left(0.05 + 0.05 \frac{0.1 \times \text{URL}}{\text{Span}} \right) \% \text{ of span}$$

Stability: $\pm 0.2\%$ of upper range limit (URL) for 10 years.

Temperature effect:

Effect per 28°C change between the limits of -40°C and +85°C

$$\text{Zero shift: } \pm \left(0.125 + 0.1 \frac{\text{URL}}{\text{Span}} \right) \%$$

$$\text{Total effect: } \pm \left(0.15 + 0.1 \frac{\text{URL}}{\text{Span}} \right) \%$$

Overrange effect: Zero shift; $\pm 0.2\%$ of URL for any overrange to maximum limit

Supply voltage effect:

Less than 0.005% of calibrated span per 1V

Update rate: 60 msec

Step response: Time constant: 0.08 s (at 23°C)

Dead time: 0.12 s

(without electrical damping)

Mounting position effect:

Zero shift, less than 0.1kPa{1mbar} for a 10° tilt in any plane.

No effect on span. This error can be corrected by adjusting zero.

Dielectric strength:

500V AC, 50/60Hz 1 min., between circuit and earth.

Insulation resistance:

More than 100MΩ at 500V DC.

Internal resistance for external field indicator:

12Ω or less

Physical specifications

Electrical connections:

G1/2, 1/2-14NPT, Pg13.5, or M20 x 1.5 conduit, as specified.

Process connections:

1/4-18 NPT or Rc1/4 on 54mm centers, as specified.

Process-wetted parts material:

symbols")	Material	Diaphragm	Wetted sensor body	Vent/drain
V	316 stainless steel (*)	316L stainless steel	316 stainless steel	316/316L stainless steel
H	316 stainless steel (*)	Hastelloy-C	Hastelloy-C lining	316/316L stainless steel

Note: (*) SCS14A per JIS G 5121 (equivalent CF8M per ASTM A351/A351M)

Remarks: Availability of above material design depends on ranges. Refer to "Code symbols".

Non-wetted parts material:

Electronics housing: Low copper die-cast aluminum alloy finished with polyester coating (standard), or 316 stainless steel (ASTM CF8M), as specified.

Bolts and nut: Cr-Mo alloy (standard), 304 or 316 stainless steel

Fill fluid: Silicone oil

Mounting bracket: 304 or 316 stainless steel.

Environmental protection:

IEC IP67 and NEMA 6/6P

Mounting:

On 60.5mm (JIS 50A) pipe using mounting bracket, direct wall mounting, or direct process mounting.

Mass{weight}:

Transmitter approximately 2.9 to 3.4kg without options.

Add; 0.5kg for mounting bracket

4.5kg for stainless steel housing option

Optional features

Indicator:

A plug-in analog indicator (2.5% accuracy)

An optional 5-digit LCD meter with engineering unit is also available.

Local configurator with LCD display:

An optional 5 digits LCD meter with 3 push buttons can support items as using communication with FXW.

Arrester:

A built-in arrester protects the electronics from lightning surges.

Lightning surge immunity:

4kV (1.2 × 50μs)

Degreasing:

Process-wetted parts are cleaned, but the fill fluid is standard silicone oil. Not for use on oxygen or chlorine measurement.

NACE specification:

Metallic materials for all pressure boundary parts comply with NACE MR-01-75. 304 stainless steel bolts and nuts, ASTM B7M or L7M bolts and 2HM nuts (Class II) are available.

Optional tagplate:

An extra stainless steel tag for customer tag data is wired to the transmitter.

Coating of cell:

Cell's surface is finished with epoxy/polyurethane double coating. Specify if environment is extremely corrosive.

CODE SYMBOLS

Digit	Description				Note	1	2	3	4	5	6	7	8	9	10	11	12	13	14	15	21	
						F	K	A	0	5	-	-	-	-	-	-	-	-	-	-	-	-
4	<Connections>																					
	Process connection	Oval flange screw	Conduit connection	Case type																		
	Rc1/4	7/16-20UNF	G1/2	T type						5												
	1/4-18NPT	7/16-20UNF	1/2-14NPT	T type						6												
	1/4-18NPT	M10	Pg13.5	T type						7												
	1/4-18NPT	M10	M20x1.5	T type						8												
	1/4-18NPT	7/16-20UNF	Pg13.5	T type						9												
	Rc1/4	7/16-20UNF	G1/2	L type						S												
	1/4-18NPT	7/16-20UNF	1/2-14NPT	L type						T												
	1/4-18NPT	M10	Pg13.5	L type						V												
1/4-18NPT	M10	M20x1.5	L type						W													
1/4-18NPT	7/16-20UNF	Pg13.5	L type						X													
6, 7					Note1																	
	Span limit [kPa abs](bar abs)(*1)	Process cover	Diaphragm	Wetted cell body																		
	1.6...16 {0.016...0.16}	316 stainless steel	316L stainless steel	316 stainless steel								1V										
		316 stainless steel	Hast. C	Hast. C lining								1H										
	1.6...130 {0.016...1.3}	316 stainless steel	316L stainless steel	316 stainless steel								2V										
		316 stainless steel	Hast. C	Hast. C lining								2H										
9	<Indicator and arrester>																					
	<u>Indicator</u>		<u>Arrester</u>																			
	None		None																			
	Analog, 0 to 100% linear scale		None																			
	Analog, custom scale		None																			
	None		Yes																			
	Analog, 0 to 100% linear scale		Yes																			
	Analog, custom scale		Yes																			
	Digital, 0 to 100% linear scale		None																			
	Digital, custom scale		None																			
	Digital, 0 to 100% linear scale		Yes																			
	Digital, custom scale		Yes																			
Digital, 0 to 100% linear scale (Local configurator unit with LCD display)		None																				
Digital, custom scale (Local configurator unit with LCD display)		None																				
Digital, 0 to 100% linear scale (Local configurator unit with LCD display)		Yes																				
Digital, custom scale (Local configurator unit with LCD display)		Yes																				
10	<Approvals for hazardous locations>																					
	None (for ordinary locations)																					
	TIIS, Flameproof (Cable gland seal) (*6)				Note6																	
	TIIS, Intrinsic safety																					
	FM, Flameproof (or explosionproof) (*9)				Note9																	
	FM, Intrinsic safety and nonincensive																					
	FM Combined of flameproof and intrinsic safety (*9)				Note9																	
	ATEX Flameproof (*8)				Note8																	
	ATEX Intrinsic safety																					
	ATEX Type n																					
	ATEX Combined of flameproof and intrinsic safety (*8)				Note8																	
	IECEX Scheme, Flameproof (*8)				Note8																	
IECEX Scheme, Intrinsic safety																						
CSA, Flameproof (or explosionproof) (*9)				Note9																		
CSA, Intrinsic safety and nonincensive																						
NEPSI, Flameproof (or explosionproof)																						
NEPSI, Intrinsic safety																						
NEPSI, Combined of flameproof and intrinsic safety																						
11	<Vent/ drain and mounting bracket>																					
	<u>Vent/drain</u>		<u>Mounting bracket</u>																			
	Standard		None																			
	Standard		Yes, stainless steel (SUS304)																			
	Standard		Yes, stainless steel (SUS316)																			
	Side		None																			
Side		Yes, stainless steel (SUS304)																				
Side		Yes, stainless steel (SUS316)																				

Note1: (*1) 100: 1 turn down is possible, but should be used at a span greater than 1/40 of the maximum span for better performance.

Digit	Description	Note	1	2	3	4	5	6	7	8	9	10	11	12	13	14	15	21	← Digit No. of code
12	<Options>		F	K	A	0	5												
	Extra SS tag plate	Stainless steel elec. housing	Coating of cell																
	None	None	None																
	Yes	None	None																
	None	None	Yes																
	Yes	None	Yes																
13	<Special applications and fill fluid>																		
	Treatment	Fill fluid																	
	Standard	Silicone oil																	
	Degreasing	Silicone oil																	
14	NACE specification	Silicone oil (7th digit code "T" and 15th digit code "A", "B" are not available)																	
	<O-ring/Gasket and Teflon membrane>	Teflon (gasket)																	
15	<Bolt/nut> (*3)																		
	Cr-Mo alloy hexagon socket head cap screw/carbon steel nut																		
	Cr-Mo alloy hexagon bolt/nut																		
	NACE bolt/nut (ASTM A193 B7M/A194 2HM)																		
	NECE bolt/nut (ASTM A320 L7M/A194 2HM)																		
	304 stainless steel bolt/304 stainless steel nut																		
21	<Other options> (*4)																		
	High accuracy type (*7)	Instruction manual attached																	
	Opposite Vent/Drain Plug Position	Instruction manual attached																	
	High accuracy type(*7)	Instruction manual unattached																	
21	Opposite Vent/Drain Plug Position	Instruction manual unattached																	
	High accuracy type(*7)	Instruction manual unattached																	

Note2: (*2) Customer tag number can be engraved on standard stainless steel name plate. If extra tag plate is required, select "Yes".

Note3: (*3) In case of tropical use, select stainless bolts and nuts.

Note4: (*4) If other option is not necessary, 21st digit code is blank. In case of 21st digit code is blank, instruction manual attached.

Note5: (*5) Not available for 10th digit code "C".

Note6: (*6) Available for 4th digit code "S".

Note7: (*7) Available for 6th digit code "3", "4".

Note8: (*8) Available for 4th digit code "6", "8", "T", "W".

Note9: (*9) Available for 4th digit code "6", "T".

ACCESSORIES

Oval flanges: (Model FFP, refer to Data Sheet No. EDS6-128)
Converts process connection to 1/2-14 NPT or to Rc1/2; in carbon steel or in 316 stainless steel.

Hand held communicator:
(Model FXW, refer to Data Sheet No. EDS 8-47)

ORDERING INFORMATION

When ordering this instrument, specify.

1. CODE SYMBOLS
2. Measuring range.
3. Output orientation (burnout direction) when abnormality is occurred in the transmitter.
Hold / Overscale / Underscale
Unless otherwise specified, output hold function is supplied.
4. Indication method (indicated value and unit) in case of the actual scale (code D, H, P, S on 9th digit).
5. Tag No. (up to 14 alphanumeric characters), if required.

OUTLINE DIAGRAM (Unit:mm)

<AMP. case:T type>

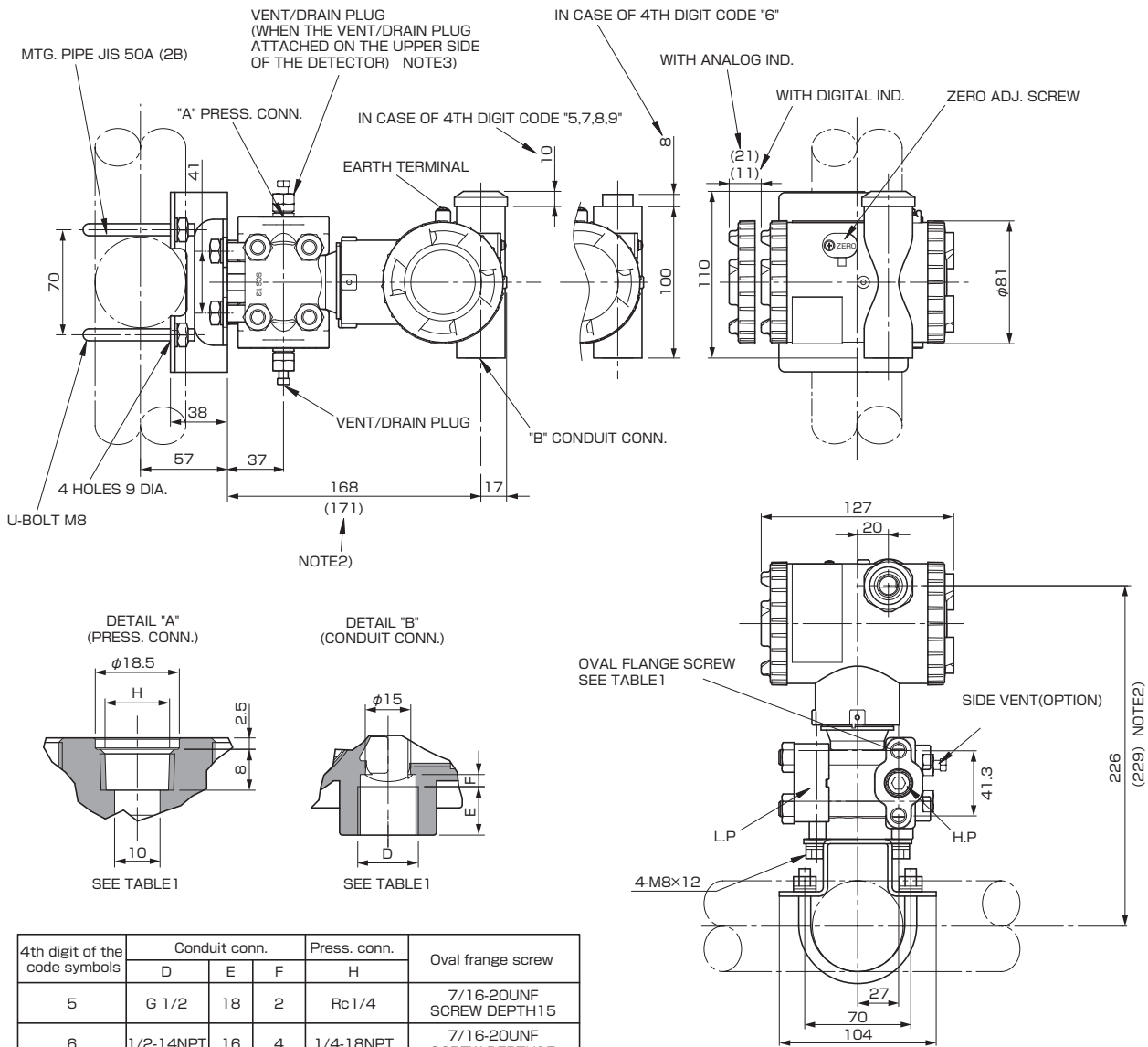

4th digit of the code symbols	Conduit conn.			Press. conn.	Oval flange screw
	D	E	F	H	
5	G 1/2	18	2	Rc1/4	7/16-20UNF SCREW DEPTH15
6	1/2-14NPT	16	4	1/4-18NPT	7/16-20UNF SCREW DEPTH15
7	Pg13.5	10.5	4.5	1/4-18NPT	M10 SCREW DEPTH15
8	M20x1.5	16	4	1/4-18NPT	M10 SCREW DEPTH15
9	Pg13.5	10.5	4.5	1/4-18NPT	7/16-20UNF SCREW DEPTH15

TABLE 1

CONNECTION DIAGRAM

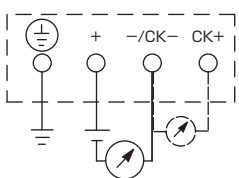

<SS TAG PLATE>

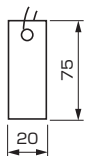

NOTE2) WHEN THE 7TH DIGIT OF THE CODE SYMBOLS "H.M.T"
NOTE3) THE PRESSURE CONNECTOR IS LOCATED ON THE DOWN SIDE SURFACE OF THE DETECTOR, WHEN THE VENT/DRAIN PLUG IS ATTACHED ON THE UPPER SIDE OF THE DETECTOR (WHEN THE 21ST DIGIT OF THE CODE SYMBOLS : C.P).

<AMP. case: L type>

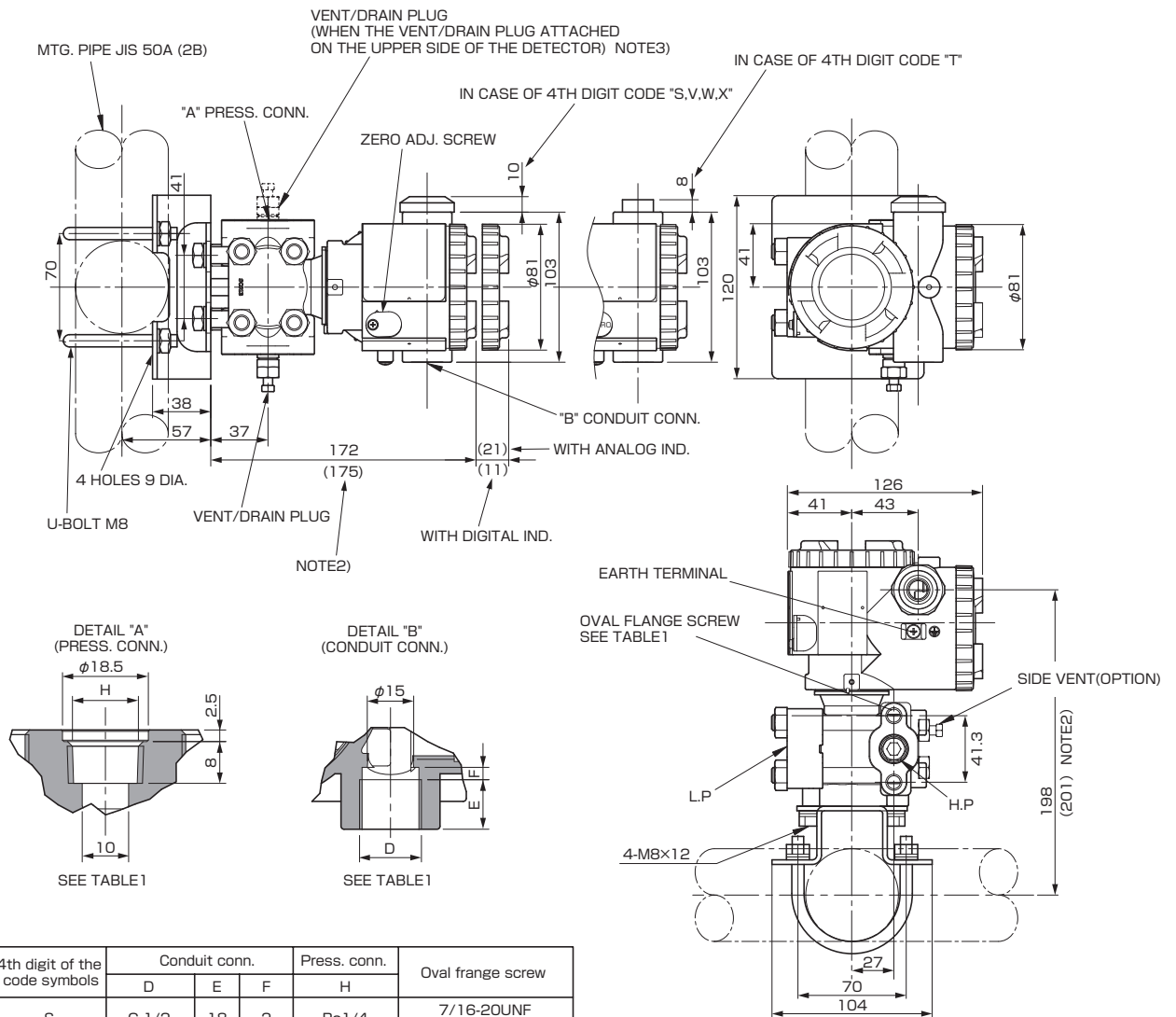

4th digit of the code symbols	Conduit conn.			Press. conn.	Oval flange screw
	D	E	F	H	
S	G 1/2	18	2	Rc1/4	7/16-20UNF SCREW DEPTH15
T	1/2-14NPT	16	4	1/4-18NPT	7/16-20UNF SCREW DEPTH15
V	Pg13.5	10.5	4.5	1/4-18NPT	M10 SCREW DEPTH15
W	M20x1.5	16	4	1/4-18NPT	M10 SCREW DEPTH15
X	Pg13.5	10.5	4.5	1/4-18NPT	7/16-20UNF SCREW DEPTH15

TABLE 1

CONNECTION DIAGRAM

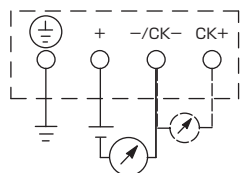

<SS TAG PLATE>

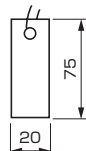

OPTION PARTS FOR FLAMEPROOF OF TIIS (JAPAN)

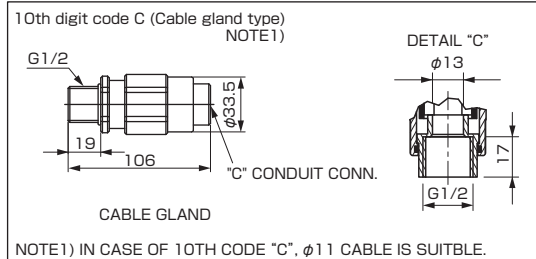

NOTE2) WHEN THE 7TH DIGIT OF THE CODE SYMBOLS "H"
 NOTE3) THE PRESSURE CONNECTOR IS LOCATED ON THE DOWN SIDE SURFACE OF THE DETECTOR. WHEN THE VENT/DRAIN PLUG IS ATTACHED ON THE UPPER SIDE OF THE DETECTOR (WHEN THE 21ST DIGIT OF THE CODE SYMBOLS : C.P).

TABLE 2

Authorities	Intrinsic safety																		
ATEX	Ex II 1 G Ex ia IIC T5 Tamb = -40°C to +50°C Ex ia IIC T4 Tamb = -40°C to +70°C Entity Parameters: Ui=28V, li=94.3mA, Pi=0.66W, Ci=26nF (Without Arrester), Li=0.6mH (Without analog indicator), Ci=36nF (With Arrester), Li=0.7mH (With analog indicator)																		
Factory Mutual	Class I II III Div.1 Groups A, B, C, D, E, F, G T4 Entity Type 4X <table border="1"> <thead> <tr> <th>Model code</th> <th>Tamb</th> </tr> </thead> <tbody> <tr> <td>9th digit</td> <td></td> </tr> <tr> <td>A,B,D</td> <td>-40°C to +85°C</td> </tr> <tr> <td>L,P1,2</td> <td>-20°C to +80°C</td> </tr> <tr> <td>Q,S,4,5</td> <td>-20°C to +60°C</td> </tr> <tr> <td>E,F,H</td> <td>-40°C to +60°C</td> </tr> </tbody> </table> Entity Parameters: Vmax=28V, Imax=94.3mA, Pi=0.66W, Ci=35.98nF, Li=0.694mH	Model code	Tamb	9th digit		A,B,D	-40°C to +85°C	L,P1,2	-20°C to +80°C	Q,S,4,5	-20°C to +60°C	E,F,H	-40°C to +60°C						
Model code	Tamb																		
9th digit																			
A,B,D	-40°C to +85°C																		
L,P1,2	-20°C to +80°C																		
Q,S,4,5	-20°C to +60°C																		
E,F,H	-40°C to +60°C																		
CSA	Class I Div.1 Groups A, B, C, D Class II Div.1 Groups E, F, G Class III Div.1 Temp Code T5 Tamb max = +50°C Temp Code T4 Tamb max = +70°C Entity Parameters: Vmax=28V, Imax=94.3mA, Ci=25nF (Without Arrester), Ci=36nF (With Arrester), Li=0.6mH (Without analog meter), Li=0.7mH (With analog meter)																		
TIIS	Ex ia IIC T4 Tamb max = +60°C Entity Parameters: Ui=28V, li=94.3mA, Pi=0.66W, Ci=38.4nF, Li=0.694mH																		
IECEx Scheme	Ex ia IIC T4 Tamb = -40°C to +70°C Ex ia IIC T5 Tamb = -40°C to +50°C Entity Parameters: Ui=28V, li=94.3mA, Pi=0.66W, Ci=26nF (Without Arrester), Li=0.6mH (Without analog indicator), Ci=36nF (With Arrester), Li=0.7mH (With analog indicator)																		
NEPSI	Ex ia IIC T4 Ex d IIB+H ₂ T6 / Ex ia IIC T4 <table border="1"> <thead> <tr> <th>Model code</th> <th colspan="2">Tamb</th> </tr> </thead> <tbody> <tr> <td>9th digit</td> <td>13th digit</td> <td></td> </tr> <tr> <td>A,B,D</td> <td>Y,G,N</td> <td>-40°C to +85°C</td> </tr> <tr> <td>L,P1,2</td> <td>Y,G,N</td> <td>-20°C to +80°C</td> </tr> <tr> <td>Q,S,4,5</td> <td>Y,G,N</td> <td>-20°C to +60°C</td> </tr> <tr> <td>E,F,H</td> <td>Y,G,N</td> <td>-40°C to +60°C</td> </tr> </tbody> </table> Entity Parameters: Ui=42.4V, li=113mA, Pi=1W, Ci=35.98nF, Li=0.694mH	Model code	Tamb		9th digit	13th digit		A,B,D	Y,G,N	-40°C to +85°C	L,P1,2	Y,G,N	-20°C to +80°C	Q,S,4,5	Y,G,N	-20°C to +60°C	E,F,H	Y,G,N	-40°C to +60°C
Model code	Tamb																		
9th digit	13th digit																		
A,B,D	Y,G,N	-40°C to +85°C																	
L,P1,2	Y,G,N	-20°C to +80°C																	
Q,S,4,5	Y,G,N	-20°C to +60°C																	
E,F,H	Y,G,N	-40°C to +60°C																	

Authorities	Flameproof												
ATEX	Ex II 2 GD Ex d IIC T6 IP66/67 T85°C Tamb = -40°C to +65°C Ex d IIC T5 IP66/67 T100°C Tamb = -40°C to +85°C												
Factory Mutual	Class I Div.1 Groups B, C, D T6 Type 4X Class II III Div.1 Groups E, F, G T6 Type 4X Tamb max = +60°C												
CSA	Class I Div.1 Groups C, D Class II Div.1 Groups E, F, G Class III Div.1 Note) "Seal Not Required" enclosure is allowed.												
TIIS	Ex do IIB+H ₂ T4 Tamb max = +60°C Maximum process temp. = +120°C												
IECEx Scheme	Ex d IIC T5 IP66/67 Tamb = -40°C to +85°C Ex d IIC T6 IP66/67 Tamb = -40°C to +65°C												
NEPSI	Ex d IIB+H ₂ T6 Tamb = -40°C to +60°C												
Authorities	Type n Nonincendive												
ATEX	Ex II 3 GD EEx nL IIC T5 Tamb = -40°C to +50°C EEx nL IIC T4 Tamb = -40°C to +70°C Specific Parameters: Model without arrester: Ui=42.4V, li=113mA, Pi=1W, Ci=25.18nF, Li=0.694mH Model with arrester: Ui=32V, li=113mA, Pi=1W, Ci=35.98nF, Li=0.694mH EEx nAL IIC T5 Tamb = -40°C to +50°C EEx nAL IIC T4 Tamb = -40°C to +70°C Specific Parameters: Model without arrester: Umax=42.4V, Imax=113mA, Pmax=1W Model with arrester: Umax=32V, Imax=113mA, Pmax=1W												
Factory Mutual (pending)	Class I II III Div.2 Groups A, B, C, D, F, G T4 Entity Type 4X <table border="1"> <thead> <tr> <th>Model code</th> <th>Tamb</th> </tr> </thead> <tbody> <tr> <td>9th digit</td> <td></td> </tr> <tr> <td>A,B,D</td> <td>-40°C to +85°C</td> </tr> <tr> <td>L,P1,2</td> <td>-20°C to +80°C</td> </tr> <tr> <td>Q,S,4,5</td> <td>-20°C to +60°C</td> </tr> <tr> <td>E,F,H</td> <td>-40°C to +60°C</td> </tr> </tbody> </table>	Model code	Tamb	9th digit		A,B,D	-40°C to +85°C	L,P1,2	-20°C to +80°C	Q,S,4,5	-20°C to +60°C	E,F,H	-40°C to +60°C
Model code	Tamb												
9th digit													
A,B,D	-40°C to +85°C												
L,P1,2	-20°C to +80°C												
Q,S,4,5	-20°C to +60°C												
E,F,H	-40°C to +60°C												
CSA	Class I Div.2 Groups A, B, C, D Class II Div.2 Groups E, F, G Class III Div.2 Temp Code T5 Tamb max = +50°C Temp Code T4 Tamb max = +70°C Entity Parameters: Vmax=28V, Ci=25.18nF (Without Arrester), Ci=35.98nF (With Arrester), Li=0.694mH												

⚠ Caution on Safety

*Before using this product, be sure to read its instruction manual in advance.

Fuji Electric Co., Ltd.

International Sales Div
Sales Group

Gate City Ohsaki, East Tower, 11-2, Osaki 1-chome,
Shinagawa-ku, Tokyo 141-0032, Japan

<http://www.fujielectric.com>

Phone: 81-3-5435-7280, 7281 Fax: 81-3-5435-7425

<http://www.fjielecric.com/products/instruments/>