

# GE9973

## N-CHANNEL ENHANCEMENT MODE POWER MOSFET

BVDSS	60V
RDS(ON)	80mΩ
ID	14A

### Description

The GE9973 provide the designer with the best combination of fast switching, ruggedized device design, low on-resistance and cost-effectiveness.

The TO-220 package is universally preferred for all commercial-industrial applications and suited for low voltage applications such as DC/DC converters.

### Features

- \*Simple Drive Requirement
- \*Low Gate Charge

### Package Dimensions

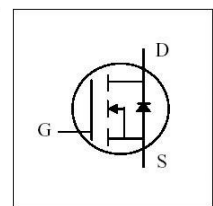
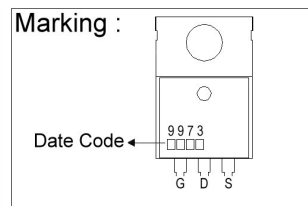
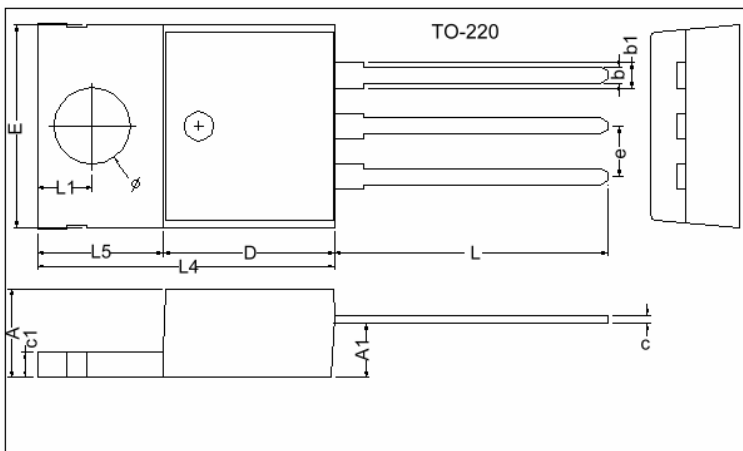

REF.	Millimeter		REF.	Millimeter	
	Min.	Max.		Min.	Max.
A	4.40	4.80	c1	1.25	1.45
b	0.76	1.00	b1	1.17	1.47
c	0.36	0.50	L	13.25	14.25
D	8.60	9.00	e	2.54 REF.	
E	9.80	10.4	L1	2.60	2.89
L4	14.7	15.3	∅	3.71	3.96
L5	6.20	6.60	A1	2.60	2.80

### Absolute Maximum Ratings

Parameter	Symbol	Ratings	Unit
Drain-Source Voltage	$V_{DS}$	60	V
Gate-Source Voltage	$V_{GS}$	±20	V
Continuous Drain Current, $V_{GS}@10V$	$I_D @T_C=25^{\circ}C$	14	A
Continuous Drain Current, $V_{GS}@10V$	$I_D @T_C=100^{\circ}C$	9	A
Pulsed Drain Current <sup>1</sup>	$I_{DM}$	40	A
Total Power Dissipation	$P_D @T_C=25^{\circ}C$	27	W
Linear Derating Factor		0.22	W/°C
Operating Junction and Storage Temperature Range	$T_j, T_{stg}$	-55 ~ +150	°C

### Thermal Data

Parameter	Symbol	Value	Unit
Thermal Resistance Junction-case Max.	$R_{thj-c}$	4.5	°C/W
Thermal Resistance Junction-ambient Max.	$R_{thj-a}$	62	°C/W

**Electrical Characteristics(T<sub>j</sub> = 25°C Unless otherwise specified)**

Parameter	Symbol	Min.	Typ.	Max.	Unit	Test Conditions
Drain-Source Breakdown Voltage	$BV_{DSS}$	60	-	-	V	$V_{GS}=0, I_D=250\mu A$
Breakdown Voltage Temperature Coefficient	$\Delta BV_{DSS} / \Delta T_j$	-	0.05	-	V/°C	Reference to 25°C, $I_D=1mA$
Gate Threshold Voltage	$V_{GS(th)}$	1.0	-	3.0	V	$V_{DS}=V_{GS}, I_D=250\mu A$
Forward Transconductance	$g_{fs}$	-	8.6	-	S	$V_{DS}=10V, I_D=9A$
Gate-Source Leakage Current	$I_{GSS}$	-	-	±100	nA	$V_{GS}= \pm 20V$
Drain-Source Leakage Current(T <sub>j</sub> =25°C)	$I_{DSS}$	-	-	1	uA	$V_{DS}=60V, V_{GS}=0$
Drain-Source Leakage Current(T <sub>j</sub> =150°C)		-	-	25	uA	$V_{DS}=48V, V_{GS}=0$
Static Drain-Source On-Resistance <sup>2</sup>	$R_{DS(ON)}$	-	-	80	mΩ	$V_{GS}=10V, I_D=9A$
		-	-	100		$V_{GS}=4.5V, I_D=6A$
Total Gate Charge <sup>2</sup>	$Q_g$	-	8	13	nC	$I_D=9A$ $V_{DS}=48V$ $V_{GS}=4.5V$
Gate-Source Charge	$Q_{gs}$	-	3	-		
Gate-Drain ("Miller") Charge	$Q_{gd}$	-	4	-		
Turn-on Delay Time <sup>2</sup>	$T_{d(on)}$	-	7	-	ns	$V_{DS}=30V$ $I_D=9A$ $V_{GS}=10V$ $R_G=3.3\Omega$ $R_D=3.3\Omega$
Rise Time	$T_r$	-	15	-		
Turn-off Delay Time	$T_{d(off)}$	-	16	-		
Fall Time	$T_f$	-	3	-		
Input Capacitance	$C_{iss}$	-	720	1150	pF	$V_{GS}=0V$ $V_{DS}=25V$ $f=1.0MHz$
Output Capacitance	$C_{oss}$	-	77	-		
Reverse Transfer Capacitance	$C_{rss}$	-	45	-		

**Source-Drain Diode**

Parameter	Symbol	Min.	Typ.	Max.	Unit	Test Conditions
Forward On Voltage <sup>2</sup>	$V_{SD}$	-	-	1.2	V	$I_S=14A, V_{GS}=0V$
Reverse Recovery Time	$T_{rr}$	-	28	-	ns	$I_S=9A, V_{GS}=0V$ $di/dt=100A/\mu s$
Reverse Recovery Charge	$Q_{rr}$	-	27	-	nC	

Notes: 1. Pulse width limited by Max. junction temperature.

2. Pulse width  $\leq 300\mu s$ , duty cycle  $\leq 2\%$ .

## Characteristics Curve

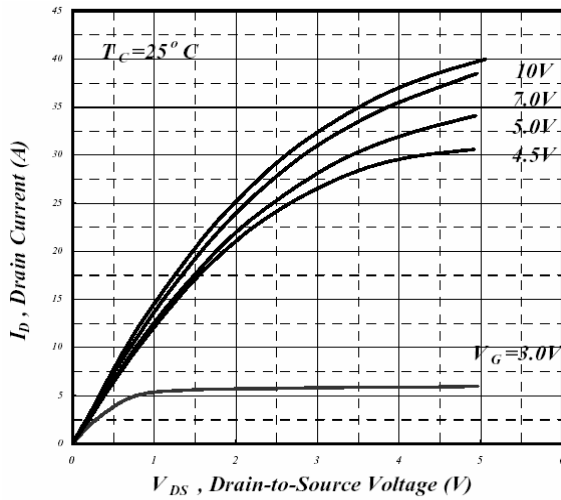

**Fig 1. Typical Output Characteristics**

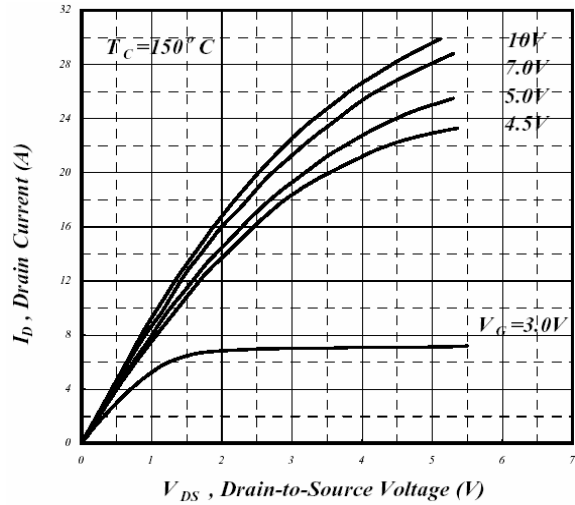

**Fig 2. Typical Output Characteristics**

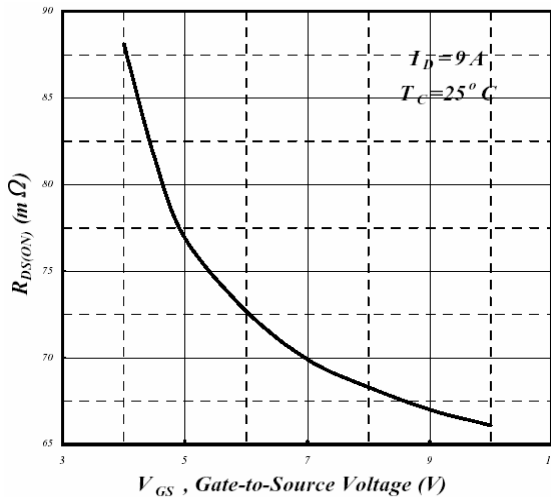

**Fig 3. On-Resistance v.s. Gate Voltage**

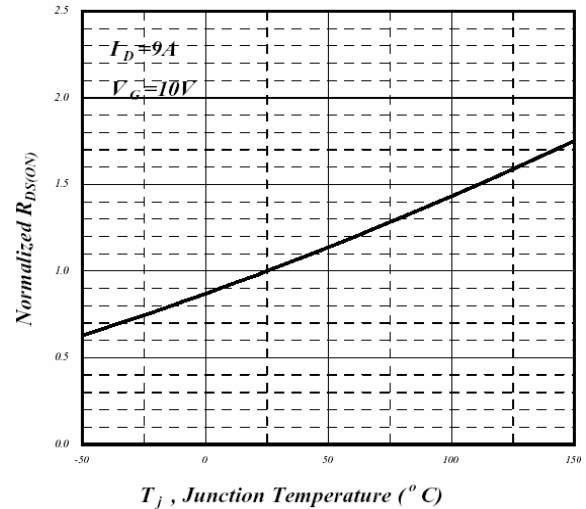

**Fig 4. Normalized On-Resistance v.s. Junction Temperature**

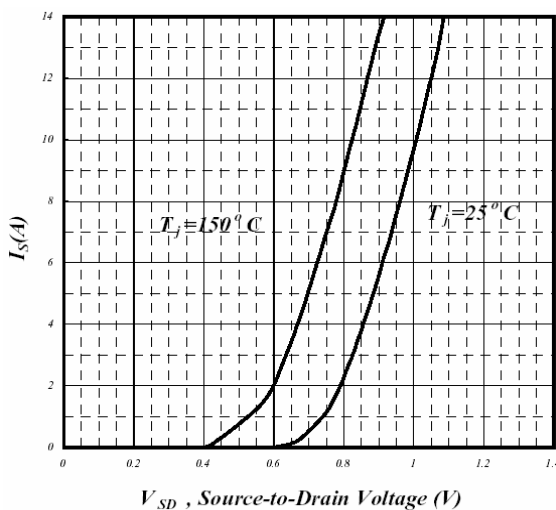

**Fig 5. Forward Characteristics of Reverse Diode**

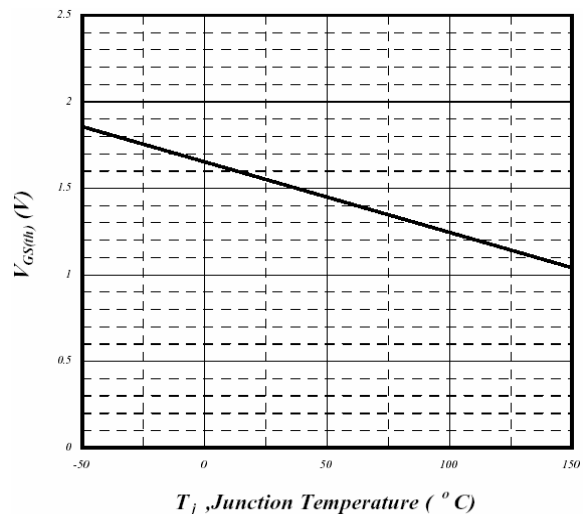

**Fig 6. Gate Threshold Voltage v.s. Junction Temperature**

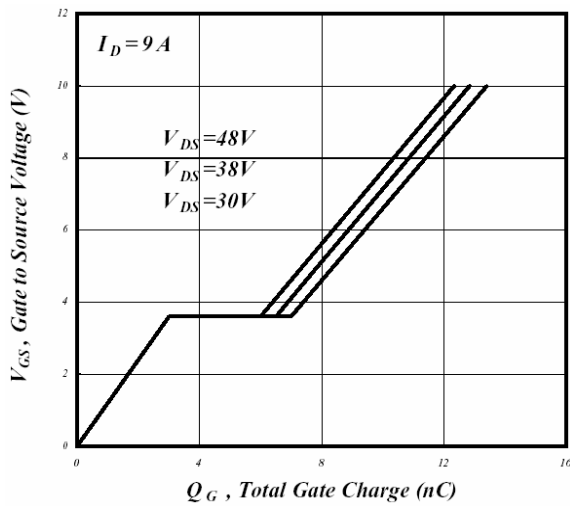

**Fig 7. Gate Charge Characteristics**

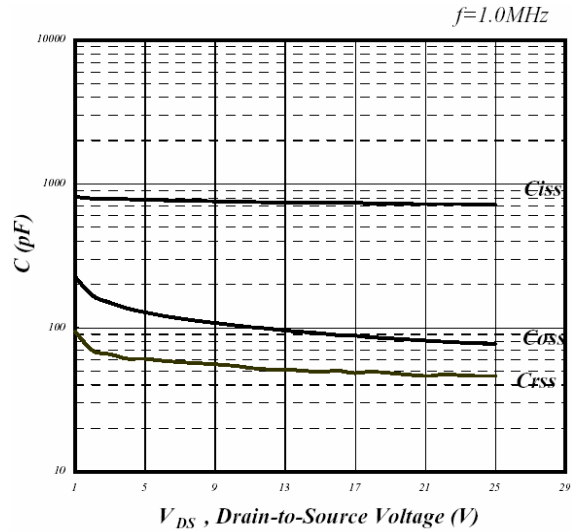

**Fig 8. Typical Capacitance Characteristics**

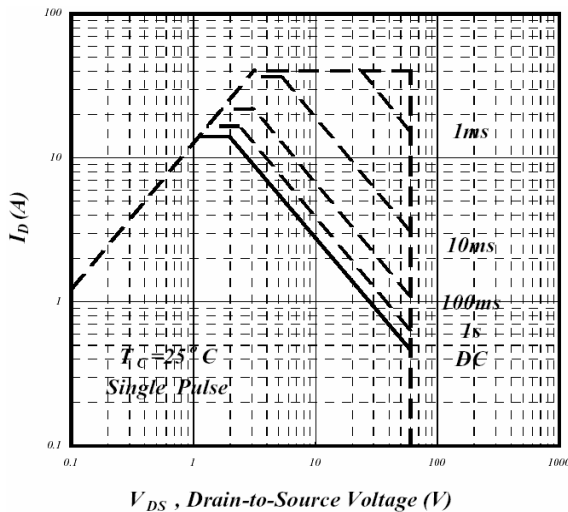

**Fig 9. Maximum Safe Operating Area**

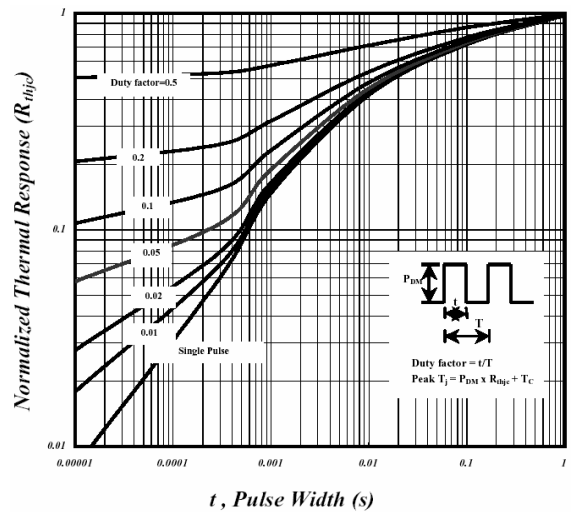

**Fig 10. Effective Transient Thermal Impedance**

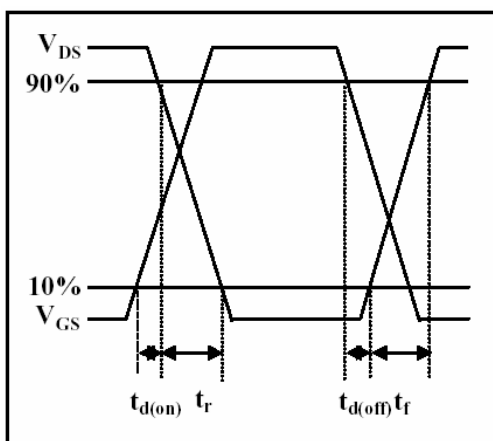

**Fig 11. Switching Time Waveform**

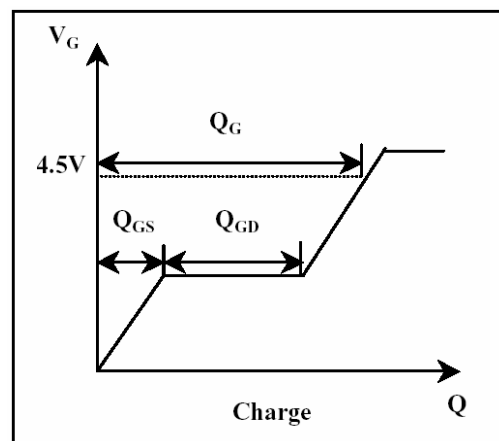

**Fig 12. Gate Charge Waveform**

**Important Notice:**

- All rights are reserved. Reproduction in whole or in part is prohibited without the prior written approval of GTM.
- GTM reserves the right to make changes to its products without notice.
- GTM semiconductor products are not warranted to be suitable for use in life-support Applications, or systems.
- GTM assumes no liability for any consequence of customer product design, infringement of patents, or application assistance.

**Head Office And Factory:**

- Taiwan:** No. 17-1 Tatung Rd. Fu Kou Hsin-Chu Industrial Park, Hsin-Chu, Taiwan, R. O. C.  
 TEL : 886-3-597-7061 FAX : 886-3-597-9220, 597-0785
- China:** (201203) No.255, Jang-Jiang Tsai-Lueng RD. , Pu-Dung-Hsin District, Shang-Hai City, China  
 TEL : 86-21-5895-7671 ~ 4 FAX : 86-21-38950165