



SGM8048

690nA, Non-Unity Gain, Quad Rail-to-Rail Input/Output Operational Amplifier

PRODUCT DESCRIPTION

The SGM8048 operates with a single supply voltage as low as 1.4V, while drawing less than 690nA (TYP) of quiescent current per amplifier. This device is also designed to support rail-to-rail input and output operation. This combination of features supports battery-powered and portable applications.

The SGM8048 has a gain-bandwidth product of 100kHz (TYP) and is stable for gains ≥ 10 . The combination of characteristics makes the SGM8048 ideal for low frequency applications, such as battery current monitoring and sensor conditioning.

The SGM8048 operational amplifier is offered in quad configuration and it is specified for the extended industrial (-40°C to +85°C) temperature range. The SGM8048 is available in the Green SOIC-14, TSSOP-14 packages.

TYPICAL APPLICATION

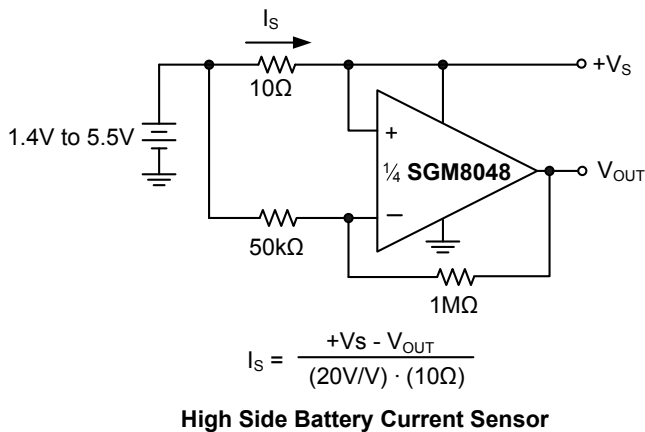

FEATURES

- **Low Quiescent Current: 690nA/Amplifier (TYP)**
- **Rail-to-Rail Input and Output**
- **Gain-Bandwidth Product: 100kHz (TYP)**
- **Stable for Gains ≥ 10**
- **Wide Supply Voltage Range: 1.4V to 5.5V**
- **-40°C to +85°C Operating Temperature Range**
- **Available in Green SOIC-14, TSSOP-14 Packages**

APPLICATIONS

- Toll Booth Tags
- Wearable Products
- Temperature Measurement
- Battery Powered System

PIN CONFIGURATIONS (TOP VIEW)

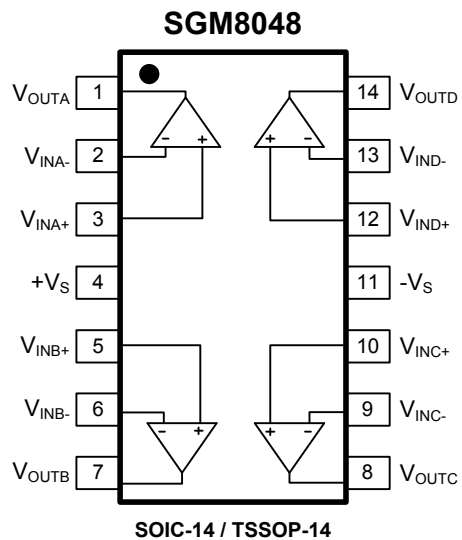

SGM8048

690nA, Non-Unity Gain, Quad Rail-to-Rail Input/Output Operational Amplifier

PACKAGE/ORDERING INFORMATION

MODEL	ORDER NUMBER	PACKAGE DESCRIPTION	PACKAGE OPTION	MARKING INFORMATION
SGM8048	SGM8048YS14G/TR	SOIC-14	Tape and Reel, 2500	SGM8048YS14
	SGM8048YTS14G/TR	TSSOP-14	Tape and Reel, 3000	SGM8048YTS14

ABSOLUTE MAXIMUM RATINGS

Supply Voltage	.6V
Analog Inputs (V_{IN+} , V_{IN-})	$(-V_S) - 0.1V$ to $(+V_S) + 0.1V$
Differential Input Voltage	$(-V_S) - (+V_S)$
Storage Temperature Range	$-65^{\circ}C$ to $+150^{\circ}C$
Junction Temperature	$150^{\circ}C$
Operating Temperature Range	$-40^{\circ}C$ to $+85^{\circ}C$
Lead Temperature (Soldering 10sec)	
	$260^{\circ}C$
ESD Susceptibility	
HBM	4000V
MM	400V

NOTE:

Stresses beyond those listed under "Absolute Maximum Ratings" may cause permanent damage to the device. These are stress ratings only, and functional operation of the device at these or any other conditions beyond those indicated in the operational sections of the specifications is not implied. Exposure to absolute maximum rating conditions for extended periods may affect device reliability.

CAUTION

This integrated circuit can be damaged by ESD if you don't pay attention to ESD protection. SGMICRO recommends that all integrated circuits be handled with appropriate precautions. Failure to observe proper handling and installation procedures can cause damage. ESD damage can range from subtle performance degradation to complete device failure. Precision integrated circuits may be more susceptible to damage because very small parametric changes could cause the device not to meet its published specifications.

SGMICRO reserves the right to make any change in circuit design, specification or other related things if necessary without notice at any time. Please contact SGMICRO sales office to get the latest datasheet.

ELECTRICAL CHARACTERISTICS

$+V_S = +1.4V$ to $+5.0V$, $-V_S = GND$, $T_A = +25^\circ C$, $A_V = 10$, $V_{CM} = +V_S/2$, $V_{OUT} \approx +V_S/2$ and $R_L = 1M\Omega$ to $+V_S/2$ ⁽¹⁾, unless otherwise noted.

PARAMETER		CONDITIONS	MIN	TYP	MAX	UNITS
DC ELECTRICAL CHARACTERISTICS						
Input Offset Voltage (V_{OS})		$V_{CM} = +V_S/2$		0.8	2.5	mV
Input Offset Voltage Drift ($\Delta V_{OS}/\Delta T$)		$V_{CM} = +V_S/2$, $-40^\circ C \leq T_A \leq +85^\circ C$		2.5		$\mu V/^\circ C$
Power Supply Rejection Ratio (PSRR)		$+V_S = 1.4V$ to $5.5V$	74	80		dB
Input Common Mode Voltage Range (V_{CMR})			$-V_S - 0.1$		$+V_S + 0.1$	V
Common Mode Rejection Ratio (CMRR)		$+V_S = 5.0V$, $V_{CM} = -0.1V$ to $5.1V$	68	83		dB
		$+V_S = 5.0V$, $V_{CM} = 2.5V$ to $5.1V$	65	81		
		$+V_S = 5.0V$, $V_{CM} = -0.1V$ to $2.5V$	70	79		
Large Signal Voltage Gain (A_{VO})		$+V_S = 1.4V$, $R_L = 50k\Omega$, $V_{OUT} = +V_S - 0.1V$	70	79		dB
		$+V_S = 2.5V$, $R_L = 50k\Omega$, $V_{OUT} = +V_S - 0.1V$		88		
		$+V_S = 5.0V$, $R_L = 50k\Omega$, $V_{OUT} = +V_S - 0.1V$	83	92		
Input Bias Current (I_B)				1		pA
Input Offset Current (I_{OS})				1		pA
Maximum Output Voltage Swing	V_{OH}	$+V_S = 1.4V$, $R_L = 50k\Omega$	1.390	1.395		V
		$+V_S = 2.5V$, $R_L = 50k\Omega$		2.497		
		$+V_S = 5.0V$, $R_L = 50k\Omega$	4.990	4.996		
	V_{OL}	$+V_S = 1.4V$, $R_L = 50k\Omega$		5.4	10	mV
		$+V_S = 2.5V$, $R_L = 50k\Omega$		3.4		
		$+V_S = 5.0V$, $R_L = 50k\Omega$		3.7	10	
Short Circuit Current (I_{SC})		$+V_S = 2.5V$		5.3		mA
		$+V_S = 5.0V$	22	23		
Supply Voltage			1.4		5.5	V
Quiescent Current/Amplifier (I_Q)		$+V_S = 1.4V$		550		nA
		$+V_S = 2.5V$		680		
		$+V_S = 5.0V$		690	1500	

SGM8048

690nA, Non-Unity Gain, Quad Rail-to-Rail Input/Output Operational Amplifier

ELECTRICAL CHARACTERISTICS

$+V_S = +1.4V$ to $+5.0V$, $-V_S = GND$, $T_A = +25^\circ C$, $A_V = 10$, $V_{CM} = +V_S/2$, $V_{OUT} \approx +V_S/2$ and $R_L = 1M\Omega$ to $+V_S/2$, $C_L = 60pF$ ⁽¹⁾, unless otherwise noted.

PARAMETER	CONDITIONS	MIN	TYP	MAX	UNITS
AC ELECTRICAL CHARACTERISTICS					
Gain-Bandwidth Product			100		kHz
Slew Rate (SR)	$+V_S = 1.4V$, $V_{OUT} = 1V$ Step		8		V/ms
	$+V_S = 2.5V$, $V_{OUT} = 1V$ Step		13.5		
	$+V_S = 5.0V$, $V_{OUT} = 2V$ Step		14.5		
Phase Margin (PM)	$+V_S = 1.4V$ to $5.5V$		60		°
Input Voltage Noise ($e_{n,p-p}$)	$+V_S = 1.4V$, $f = 0.1Hz$ to $10Hz$		3.7		μV_{P-P}
	$+V_S = 2.5V$, $f = 0.1Hz$ to $10Hz$		3.7		
	$+V_S = 5.0V$, $f = 0.1Hz$ to $10Hz$		3.5		
Input Voltage Noise Density (e_n)	$+V_S = 1.4V$, $f = 1kHz$		240		nV/\sqrt{Hz}
	$+V_S = 2.5V$, $f = 1kHz$		190		
	$+V_S = 5.0V$, $f = 1kHz$		205		

NOTE1: Refer to Figure 1 and Figure 2.

TEST CIRCUITS

The test circuits used for the DC and AC tests are shown in Figure 1 and Figure 2. The bypass capacitors are laid out according to the rules discussed in "Supply Bypass".

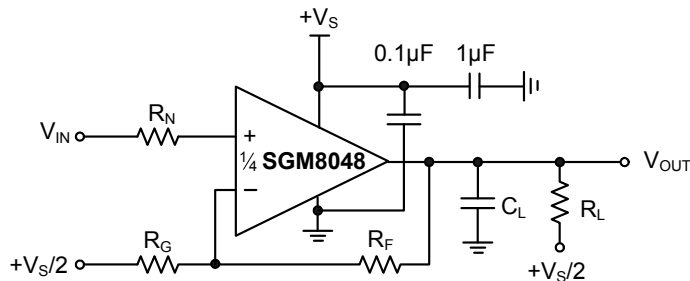

Figure 1. AC and DC Test Circuit for Most Non-Inverting Gain Conditions.

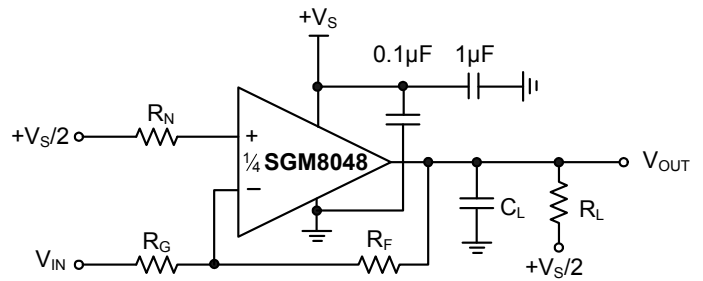
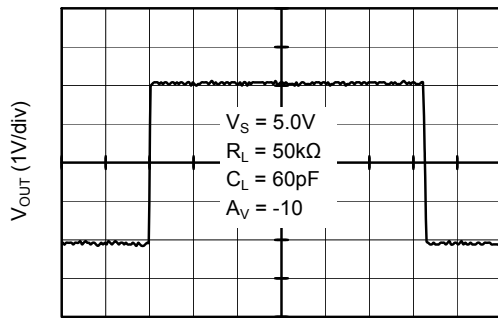

Figure 2. AC and DC Test Circuit for Most Inverting Gain Conditions.

TYPICAL PERFORMANCE CHARACTERISTICS

$T_A = +25^\circ\text{C}$, $+V_S = +1.4\text{V}$ to $+5.0\text{V}$, $-V_S = \text{GND}$, $A_V = 10$, $V_{CM} = +V_S/2$, $V_{OUT} \approx +V_S/2$ and $R_L = 1\text{M}\Omega$ to $+V_S/2$, $C_L = 60\text{pF}$, unless otherwise noted.

Large Signal Inverting Pulse Response



Time (5ms/div)

Large Signal Non-Inverting Pulse Response

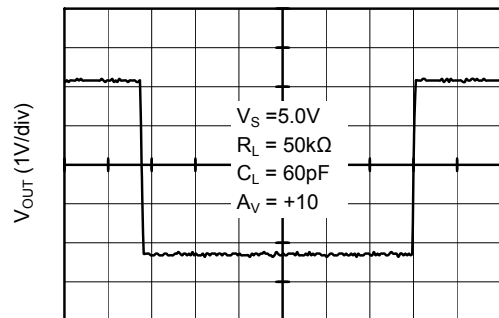

Time (5ms/div)

Small Signal Inverting Pulse Response

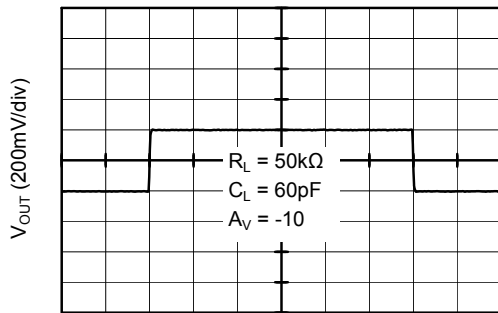

Time (5ms/div)

Small Signal Non-Inverting Pulse Response

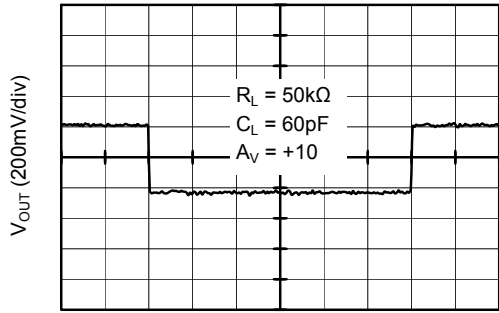

Time (5ms/div)

No Phase Reversal

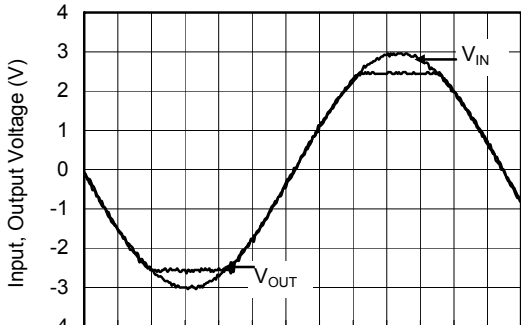

Time (5ms/div)

Slew Rate vs. Temperature

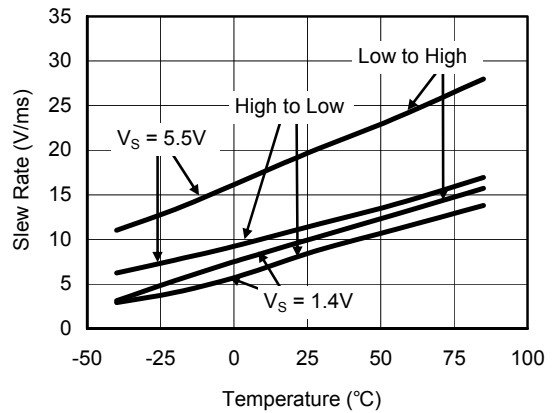

TYPICAL PERFORMANCE CHARACTERISTICS

$T_A = +25^\circ\text{C}$, $+V_S = +1.4\text{V to } +5.0\text{V}$, $-V_S = \text{GND}$, $A_V = 10$, $V_{CM} = +V_S/2$, $V_{OUT} \approx +V_S/2$ and $R_L = 1\text{M}\Omega$ to $+V_S/2$, $C_L = 60\text{pF}$, unless otherwise noted.

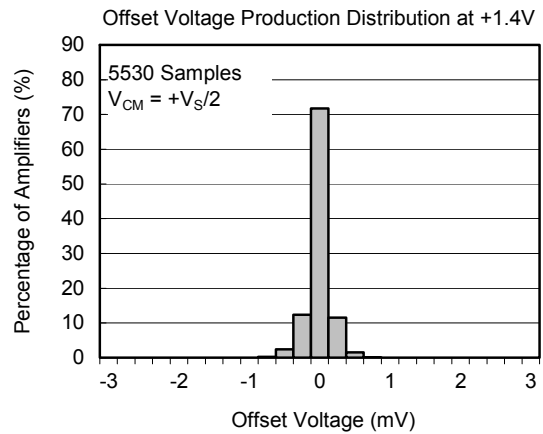
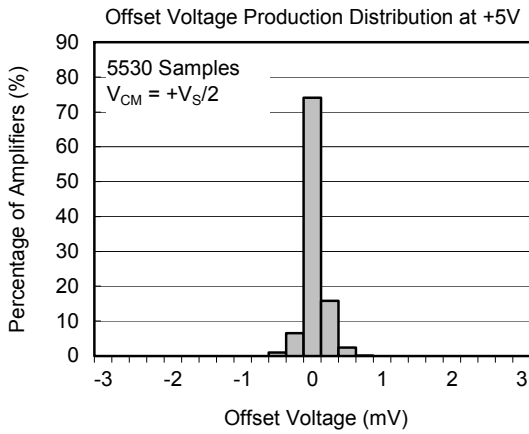

PACKAGE OUTLINE DIMENSIONS

SOIC-14

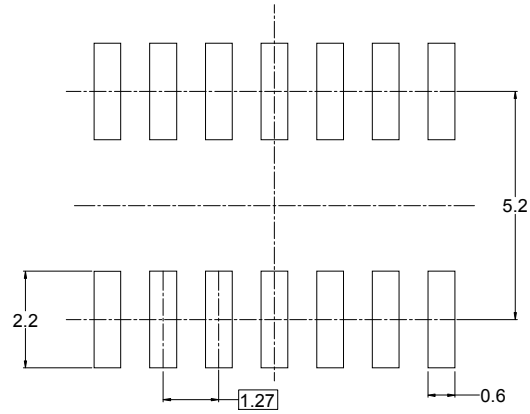
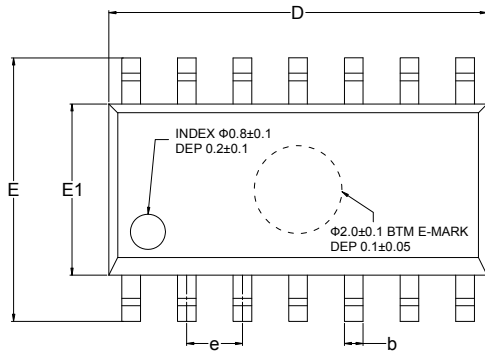

RECOMMENDED LAND PATTERN (Unit: mm)

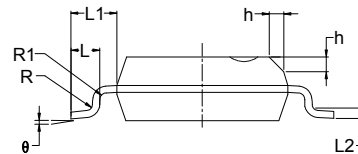
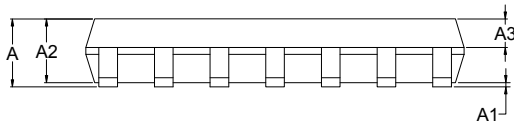

Symbol	Dimensions In Millimeters			Dimensions In Inches		
	MIN	MOD	MAX	MIN	MOD	MAX
A	1.35		1.75	0.053		0.069
A1	0.10		0.25	0.004		0.010
A2	1.25		1.65	0.049		0.065
A3	0.55		0.75	0.022		0.030
b	0.36		0.49	0.014		0.019
D	8.53		8.73	0.336		0.344
E	5.80		6.20	0.228		0.244
E1	3.80		4.00	0.150		0.157
e	1.27 BSC			0.050 BSC		
L	0.45		0.80	0.018		0.032
L1	1.04 REF			0.040 REF		
L2	0.25 BSC			0.01 BSC		
R	0.07			0.003		
R1	0.07			0.003		
h	0.30		0.50	0.012		0.020
θ	0°		8°	0°		8°

PACKAGE OUTLINE DIMENSIONS

TSSOP-14

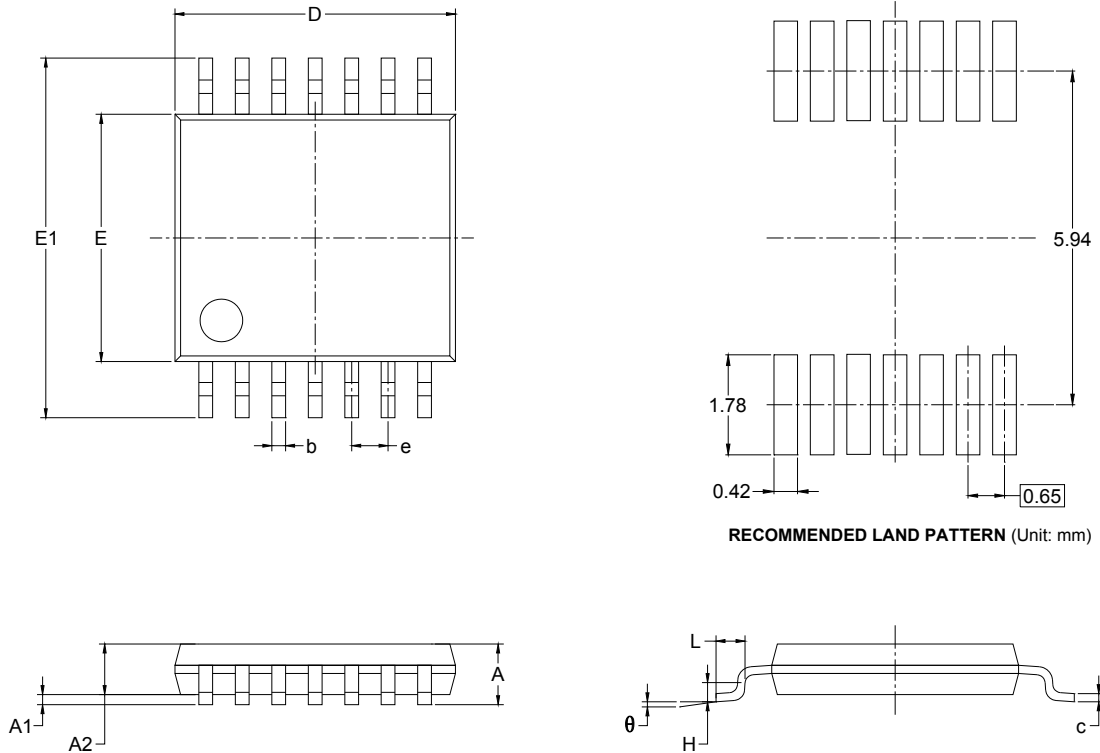

RECOMMENDED LAND PATTERN (Unit: mm)

Symbol	Dimensions In Millimeters		Dimensions In Inches	
	MIN	MAX	MIN	MAX
A		1.100		0.043
A1	0.050	0.150	0.002	0.006
A2	0.800	1.000	0.031	0.039
b	0.190	0.300	0.007	0.012
c	0.090	0.200	0.004	0.008
D	4.900	5.100	0.193	0.201
E	4.300	4.500	0.169	0.177
E1	6.250	6.550	0.246	0.258
e	0.650 BSC		0.026 BSC	
L	0.500	0.700	0.02	0.028
H	0.25 TYP		0.01 TYP	
θ	1°	7°	1°	7°

TAPE AND REEL INFORMATION

REEL DIMENSIONS

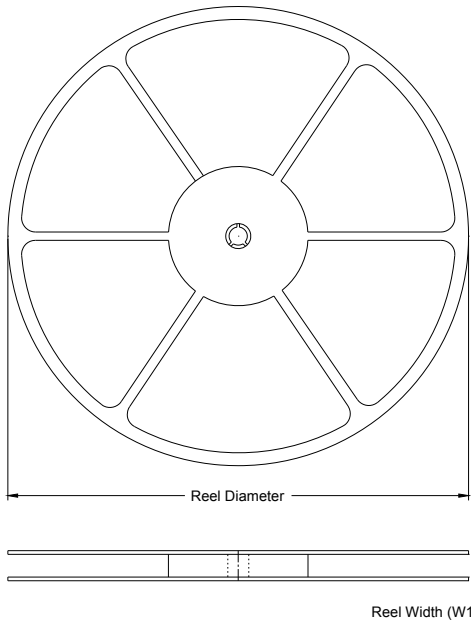

TAPE DIMENSIONS

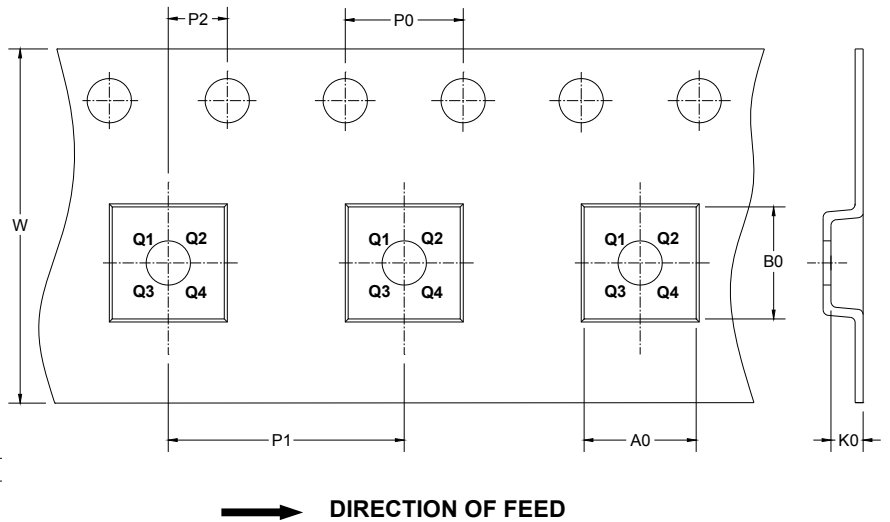

NOTE: The picture is only for reference. Please make the object as the standard.

KEY PARAMETER LIST OF TAPE AND REEL

Package Type	Reel Diameter	Reel Width W1 (mm)	A0 (mm)	B0 (mm)	K0 (mm)	P0 (mm)	P1 (mm)	P2 (mm)	W (mm)	Pin1 Quadrant
SOIC-14	13"	16.4	6.6	9.3	2.1	4.0	8.0	2.0	16.0	Q1
TSSOP-14	13"	12.4	6.95	5.6	1.2	4.0	8.0	2.0	12.0	Q1

SGM8048

690nA, Non-Unity Gain, Quad Rail-to-Rail Input/Output Operational Amplifier

CARTON BOX DIMENSIONS

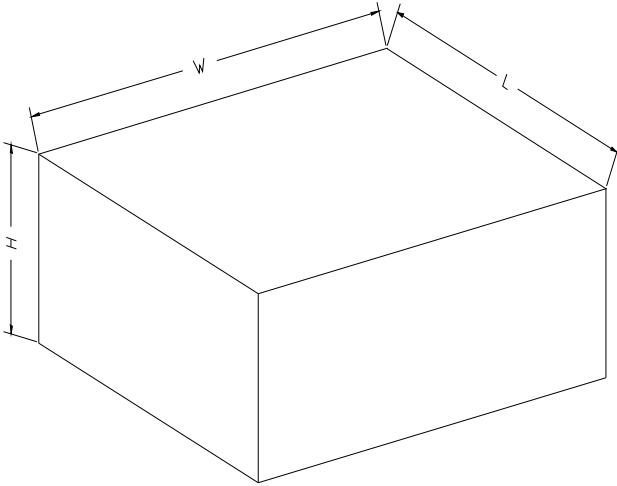

NOTE: The picture is only for reference. Please make the object as the standard.

KEY PARAMETER LIST OF CARTON BOX

Reel Type	Length (mm)	Width (mm)	Height (mm)	Pizza/Carton
13"	386	280	370	5