



Preliminary Rev0.1 2012/10/25
Features

- Wireless digital audio transmission in 2.4GHz ISM band
- 26 non-overlay channels
- Automatic adaptive frequency mechanism for interference free transmission
- Auto channel tracking
- GFSK modulation with up to 3Mbps data rate
- Super high S/N and 20 ~ 23 kHz full range Hi-Fi stereo sound quality
- 48KHz – 16Bit non-compression audio sampling rate and smooth audio streaming
- Voice 8KHz-16Bit without compression
- Programmable Latency – minimum 12.5ms
- ID codes to provide TX / RX pairing
- Low Power Consumption
- Highly Robust Forward Error Correction (FEC)
- Robust Packet error correction
- Unlimited Broadcasting Receivers
- USB and analog dual audio input

Applications

- Low Cost/High Performance Wireless Audio
 - Wireless Surround Rear Speakers
 - High Performance Digital Audio Link
 - Wireless Headphone/Earphone
 - Wireless USB Audio Stream Transmitter
 - Wireless Digital Microphone
 - Audio Baby Monitor
 - SKYPE phone
 - Walkie Talkie
- FCC CFR47 Part 15, ETSI EN 300 328, EN 300 440 and ARIB STD-T-66 Compliant Radio

General Description

The RF module transmitter employed GFSK modulation to deliver high-speed data rate up to 3Mbps.

The RF module receiver with -85dBm or better sensitivity allows system to achieve at least 220 feet transmission for line-of-sight application in open site.

AIRWAVE TECHNOLOGIES INC.



AWD627T Module Absolute Maximum Ratings

Parameter	Condition	Min.	Typ	Max	Units
Supply voltage	Vs			5.25	V
Storage temperature	Tstg	-40	25	+125	°C
Operating temperature	To	0	25	+55	°C

AWD626R Module Absolute Maximum Ratings

Parameter	Condition	Min.	Typ	Max	Units
Supply voltage	Vs			5.25	V
Storage temperature	Tstg	-40	25	+125	°C
Operating temperature	To	0	25	+55	°C
Input RF level	Prf			-2	dBm

General

RF Specification				
Item	Min.	Typ	Max	Units
Frequency Range	2403		2478	MHz
RF Data Rate		3		Mbps
Channel Spacing		3		MHz
RF TX Power		15		dBm
RF Tx Frequency Drift		+/-50		kHz
Rx Sensitivity@1%PER		-85		dBm

Audio Specification				
Item	Min.	Typ	Max	Units
Non-compression audio Sampling Rate		48		kHz
Non-compression audio resolution		16		Bits
Frequency Response	20		23k	Hz
SNR		95		dB
THD + N		-95		dB
Voice Sampling Rate		8		kHz
Voice resolution		16		Bits
Latency	12.5			ms
Crosstalk		96		dB
FSIV		1		Vrms
FSOV		1		Vrms

AIRWAVE TECHNOLOGIES INC.



Electrical Specification				
Item	Min.	Typ	Max	Units
Tx Power supply voltage	.3.3	3.3	5.25	V
Rx Power supply voltage	. 3.3	3.3	5.25	V
Tx Power supply current	.	100 tbd		mA
Rx Power supply current	.	100 tbd		mA
Operating Temperature	.-10		60	°C

AWD627T Module

Test condition: Vs=3.3V, Input=1kHz @ 1Vp-p & room temperature, unless otherwise specified.

Parameter	Condition	Min.	Typ	Max	Units
Supply voltage	Vs	3.3	3.3	5.25	V
Supply current	Vs=3.3V		100 tbd		mA
Operating Frequency		2403		2478	MHz
Transmission Power	Conductive measurement		15		dBm
Modulation Type	GFSK				
Frequency Deviation			+/-0.1		MHz
Channel Spacing			3		MHz
RF Tx Frequency Drift			+/-50		kHz
Audio Input Level	Vs=3.3V,peak to peak value		1		Vrms
Audio Input Impedance	48kHz audio sampling rate	13k	20k		Ohm
Data Rate	Software defined		3	3	Mbps
Audio Sampling Rate	Software defined		48		kHz

AIRWAVE TECHNOLOGIES INC.



AWD626R Module

Test condition: $V_s=3.3V$, Input=1kHz @ 1Vp-p & room temperature, unless otherwise specified.

Parameter	Condition	Min.	Typ	Max	Units
Supply voltage	V_s	3.3	3.3	5.25	V
Supply current			100 tbd		mA
Operating Frequency		2403		2478	MHz
Rx Sensitivity	BER=1e-3 @ 3Mbps input		-85		dBm
Image Rejection	Relative to main carrier signal power	47			dBc
Audio Output Level			1		Vrms
Audio Output Impedance			16		Ohm
Audio frequency response	3dB bandwidth	20		23K	Hz
Data Rate			2		Mbps

AIRWAVE TECHNOLOGIES INC.



AIRWAVE

Preliminary

AWD627T, AWD626R

2.4GHz Digital Audio RF Module

AWD627T Baseband B.O.M.			
Comment	Designator	Footprint	Quantity
0.1uF	C21	RLC0402	1
2.2uF	C22	RLC0603	1
220uF	C23, C24	E CAP 6.3*5	2
4.7uF	C25	RLC0603	1
22uF	C26		1
PMEG2010EA	D7	PMEG2010EA	1
BAT54CW	D8	BAT54CW	1
BLUE LED	D9	0603 SMD LED (H:0.4mm)	1
Mini USB SMT (Female)	JK5	MINI USB SMT (Female)	1
PJ-3530	JK6, JK7	PJ-3530	2
AWD627T	M1	TWO WAY MODULE	1
RED LED	LED5, LED6	0603 SMD LED (H:0.4mm)	2
MICROPHONE	MK3	PJ311-A	1
SSS2301A	Q12	SOT23_BEC	1
PUMX1	Q7, Q13	PUMX1	2
1K	R46, R53	RLC0402	2
22R	R49, R50	RLC0402	2
4.7K	R51	RLC0402	1
0R	R52	RLC0402	1
100KR	R54	RLC0402	1
2.2KR	R55	RLC0402	1
3KR	R56	RLC0402	1
47KR	R57	RLC0402	1
680R	R58	RLC0402	1
Slide Switch	S1		1
Metal Snap Dome Button x3	SW11, SW14, SW15, SW16	Metal Snap Dome Button x3	4
Analog switch	SW12		1
24MHZ_AT-26	Y3	24MHZ_AT-26	1

AIRWAVE TECHNOLOGIES INC.



AWD627T Module Pin Assignment

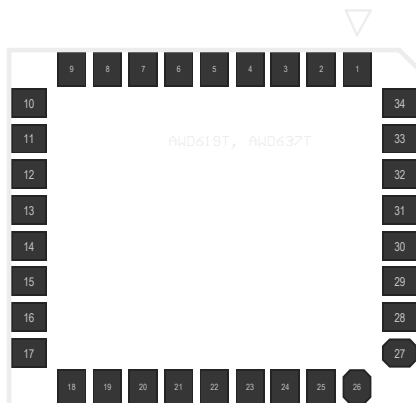

Pin No	Name	Functional Grouping	IO Type	Description
1	GND	Ground		Ground
2	ANT	RF Signal	Output	2.4GHz antenna
3	GND	Ground		Ground
4	I2C_SCL	Signal	Input	I2C interface
5	GND	Ground		Ground
6	LED	Control	Output	PAIRING status indication
7	NC	Control	Input	
8	Line In Selection	Control	Output	Output high for MIC input; Ouput low for Line_IN
9	I2C_SDA	Signal	Input	I2C interface
10	GND	Ground		Ground
11	NC			
12	NC			
13	MUTE	Control	Output	
14	XC1	Signal	Input	24MHz 20pF 30ppm Crystal Input
15	XC2	Signal	Input	24MHz 20pF 30ppm Crystal Input
16	MIC ON / Audio Out / Pairing 1	Control	Input	Pin 16 and PIN 20 pull-low continuously for over 3 seconds to enter into PAIRING mode and AWD626R can perform the PAIRING process within 15 seconds. Normal high; every pulling-low for less than 2 seconds MIC ON / Audio Out and Pin8 ouput high.
17	AGND	Analog GND		Analog Ground
18	AGND	Analog GND		Analog Ground
19	AGND	Analog GND		Analog Ground
20	MIC OFF / Audio IN / Pairing 2	Control	Input	Pin 16 and PIN 20 pull-low continuously for over 3 seconds to enter into PAIRING mode and AWD626R can perform the PAIRING process within 15 seconds. Normal high; every pulling-low for less than 2 seconds MIC ON / Audio Out and Pin8 ouput high.
21	AOR	Signal	Output	R-ch Analog Output
22	AGND	Analog GND		Analog Ground
23	AOL	Signal	Output	L-ch Analog Output
24	AINR / MIC-	Signal	Input	R-ch Analog Input / MIC- input
25	AINL / MIC+	Signal	Input	L-ch Analog Input / MIC+ input
26	VCC_CODEC	Power	Output	3V Output

AIRWAVE TECHNOLOGIES INC.



AIRWAVE

Preliminary

AWD627T, AWD626R

2.4GHz Digital Audio RF Module

Page 8 of 12

27	Vin	Power	Input	VDD
28	USBP	Signal	Input	USB DP
29	USBN	Signal	Input	USB DN
30	BAT_LOW	Signal	Output	Output Low when battery low
31	Audio Selection	Control	Input	Audio Source Selection: 3.3V for USB, GND for Analog input
32	Power Keep	Control	Output	Power Control Out
33	Power ON	Control	Input	Power Control In
34	GND	Ground		Ground

AIRWAVE TECHNOLOGIES INC.

4F, No.9 Industry E. 9th RD., Science-Based Industrial Park, Hsinchu, Taiwan, R.O.C. TEL: 886-3-5778099 Fax: 886-3-5778199
Copyright © 2010 by Airwave Technologies Inc. All Specifications are subject to change without notice.



AWD626R Module Reference Design

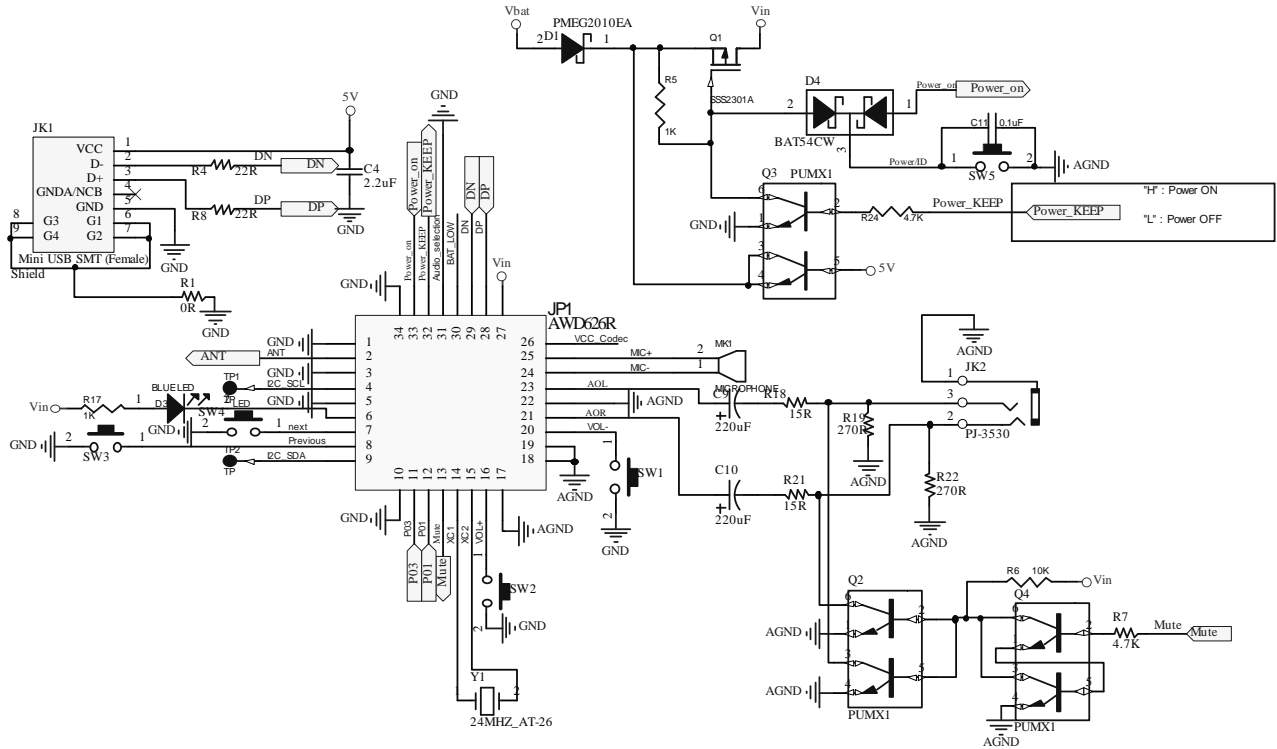

AWD626R Baseband B.O.M.			
Comment	Designator	Footprint	Quantity
2.2uF	C4	RLC0603	1
220uF	C9, C10	E CAP 6.3*5	2
0.1uF	C11	RLC0402	1
PMEG2010EA	D1	PMEG2010EA	1
BLUE LED	D3	0603 SMD LED (H:0.4mm)	1
BAT54CW	D4	BAT54CW	1
Mini USB SMT (Female)	JK1	MINI USB SMT (Female)	1
PJ-3530	JK2	PJ-3530	1
AWD626R	JP1	TWO WAY MODULE	1
MICROPHONE	MK1	PJ311-A	1
SSS2301A	Q1	SOT23_BEC	1
PUMX1	Q2, Q3, Q4	PUMX1	3
0R	R1	RLC0402	1
10K	R6	RLC0402	1
22R	R4, R8	RLC0402	2
1K	R5, R17	RLC0402	2
4.7K	R7, R24	RLC0402	2
15R	R18, R21	RLC0402	2
270R	R19, R22	RLC0402	2
Metal Snap Dome Button x3	SW1, SW2, SW3, SW4, SW5	Metal Snap Dome Button x3	5
24MHZ_AT-26	Y1	24MHZ_AT-26	1

AIRWAVE TECHNOLOGIES INC.



AWD626R Module Pin Assignment

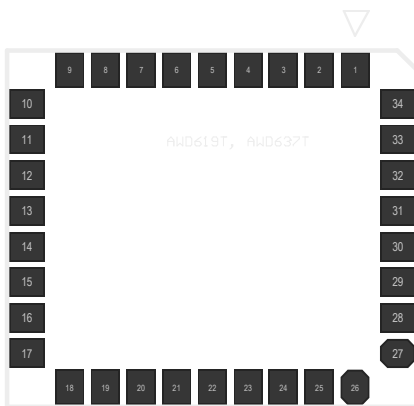

Pin No	Name	Functional Grouping	IO Type	Description
1	GND	Ground		Ground
2	ANT	RF Signal	Output	2.4GHz antenna
3	GND	Ground		Ground
4	I2C_SCL	Signal	Input	I2C interface
5	GND	Ground		Ground
6	LED	Control	Output	PAIRING status indication
7	NC	Control	Input	
8	MIC ON	Control	Input	pull-low continuously for MIC ON
9	I2C_SDA	Signal	Input	I2C interface
10	GND	Ground		Ground
11	NC			
12	NC			
13	MUTE	Control	Output	
14	XC1	Signal	Input	24MHz 20pF 30ppm Crystal Input
15	XC2	Signal	Input	24MHz 20pF 30ppm Crystal Input
16	VOL+ / Pairing 1	Control	Input	Pin 16 and PIN 20 pull-low continuously for over 3 seconds to enter into PAIRING mode and AWD626R can perform the PAIRING process within 15 seconds. Normal high; every pulling-low for less than 2 seconds Volume Up.
17	AGND	Analog GND		Analog Ground
18	AGND	Analog GND		Analog Ground
19	AGND	Analog GND		Analog Ground
20	VOL- / Pairing 2	Control	Input	Pin 16 and PIN 20 pull-low continuously for over 3 seconds to enter into PAIRING mode and AWD626R can perform the PAIRING process within 15 seconds. Normal high; every pulling-low for less than 2 seconds Volume Down.
21	AOR	Signal	Output	R-ch Analog Output
22	AGND	Analog GND		Analog Ground
23	AOL	Signal	Output	L-ch Analog Output
24	AINR / MIC-	Signal	Input	R-ch Analog Input / MIC- input
25	AINL / MIC+	Signal	Input	L-ch Analog Input / MIC+ input
26	VCC_CODEC	Power	Output	3V Output
27	Vin	Power	Input	VDD

AIRWAVE TECHNOLOGIES INC.



AIRWAVE

Preliminary

AWD627T, AWD626R

2.4GHz Digital Audio RF Module

Page 11 of 12

28	USBP	Signal	Input	USB DP
29	USBN	Signal	Input	USB DN
30	BAT_LOW	Signal	Output	Ouput Low when battry low
31	Audio Selection	Control	Input	Audio Source Selection: 3.3V for USB, GND for Analog input
32	Power Keep	Control	Output	Power Control Out
33	Power ON	Control	Input	Power Control In
34	GND	Ground		Ground

AIRWAVE TECHNOLOGIES INC.

4F, No.9 Industry E. 9th RD., Science-Based Industrial Park, Hsinchu, Taiwan, R.O.C. TEL: 886-3-5778099 Fax: 886-3-5778199
Copyright © 2010 by Airwave Technologies Inc. All Specification are subject to change without notice.



AIRWAVE

Preliminary

AWD627T, AWD626R

2.4GHz Digital Audio RF Module

AWD626R - AWD627T Dimensional Drawings

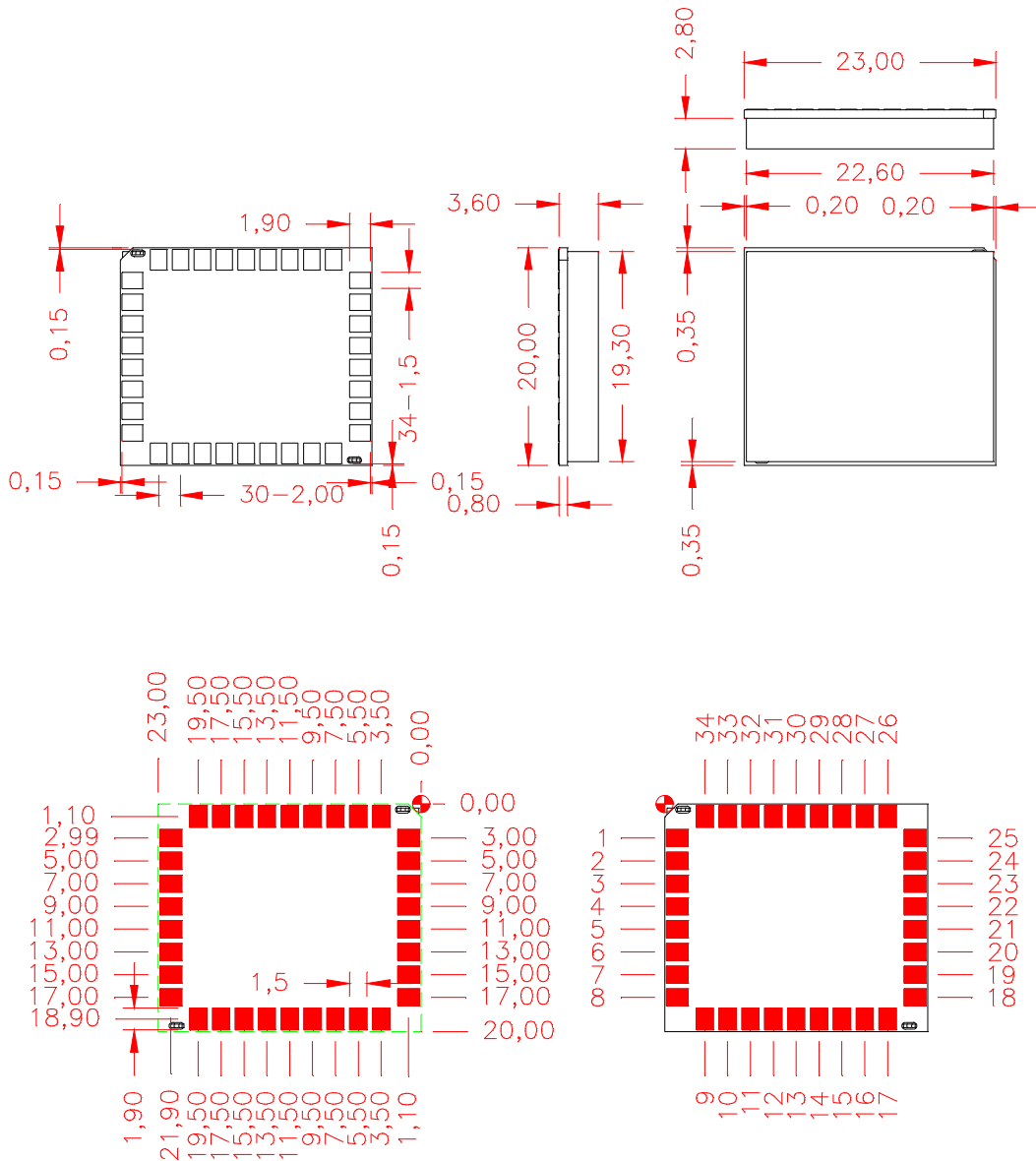

AIRWAVE TECHNOLOGIES INC.