

TPS859

- Flat Panel Displays
- Mobile Phones
- Notebook PCs, PDAs
- Video cameras, Digital Still Cameras
- Other Equipment Requiring Luminosity Adjustment

The TPS859 is an ultra-compact surface-mount photo-IC for illuminance sensors which incorporates a photodiode and current amp circuit in a single chip. The sensitivity is superior to that of a phototransistor, and exhibits little variation.

It has spectral sensitivity closer to luminous efficiency and excellent output linearity.

With its ultra-compact surface-mount package, this photo-IC can be used as the power-saving control for domestic appliances or for backlighting for displays in cellular phones, this device enables low power consumption to be achieved.

- Ultra-compact and light surface-mount package
: 1.6 mm × 1.6 mm × 0.55 mm
- Excellent output linearity of illuminance
- Little fluctuation in light current and high level of sensitivity
: $I_L = 230 \mu\text{A}$ (typ.) @ $E_V = 100 \text{ lx}$ using fluorescent light
: Light current variation width: $\times 1.67$ (When light current classification is specified.)
: Little temperature fluctuation
- Built-in luminous-efficiency correction function, reduced sensitivity variations due to various light sources
: I_L (using incandescent light) / I_L (using fluorescent light) = 1.0 (typ.)
- Low supply voltage, making device suitable for battery-powered equipment: $V_{CC} = 1.8 \text{ V}$ to 5.5 V

Maximum Ratings (Ta = 25°C)

Characteristics	Symbol	Rating	Unit
Supply voltage	V_{CC}	-0.5 to 6	V
Output voltage	V_{OUT}	$\leq V_{CC}$	V
Light current	I_L	4	mA
Permissible power dissipation	P	30	mW
Power dissipation derating (Ta > 25°C)	$\Delta P/^\circ\text{C}$	-0.4	mW/°C
Operating temperature range	T_{opr}	-30 to 85	°C
Storage temperature range	T_{stg}	-40 to 100	°C
Soldering temperature range (Note 1)	T_{sol}	260	°C

Note: Using continuously under heavy loads (e.g. the application of high temperature/current/voltage and the significant change in temperature, etc.) may cause this product to decrease in the reliability significantly even if the operating conditions (i.e. operating temperature/current/voltage, etc.) are within the absolute maximum ratings and the operating ranges.

Please design the appropriate reliability upon reviewing the Toshiba Semiconductor Reliability Handbook ("Handling Precautions"/"Derating Concept and Methods") and individual reliability data (i.e. reliability test report and estimated failure rate, etc).

Note 1: The reflow time and the recommended temperature profile are shown in the section entitled Handling Precautions.

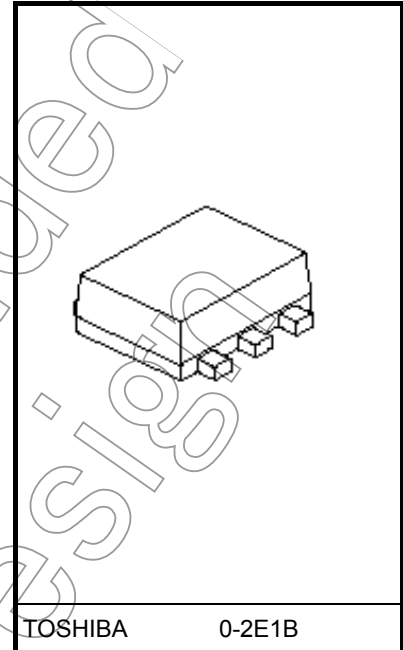

Weight: 0.003 g (typ.)

Operation Ranges

Characteristics	Symbol	Min	Typ.	Max	Unit
Supply voltage	V_{CC}	1.8	—	5.5	V
Operating temperature	T_{opr}	-30	—	85	°C

Electrical and Optical Characteristics (Ta = 25°C)

Characteristics		Symbol	Test Condition	Min	Typ.	Max	Unit
Supply voltage		V_{CC}	—	1.8	—	5.5	V
Supply current		$I_{CC}(1)$	$V_{CC} = 3\text{ V}$, $E_V = 1000\text{ lx}$ $R_L = 1\text{ k}\Omega$ (Note 2), (Note 5)	—	2300	—	μA
Light current (1)		$I_L(1)$	$V_{CC} = 3\text{ V}$, $E_V = 100\text{ lx}$ (Note 2), (Note 4)	—	230	—	μA
Light current (2)		$I_L(2)$	$V_{CC} = 3\text{ V}$, $E_V = 10\text{ lx}$ (Note 3), (Note 4)	16	23	32	μA
Light current (3)		$I_L(3)$	$V_{CC} = 3\text{ V}$, $E_V = 100\text{ lx}$ (Note 3), (Note 4)	—	230	320	μA
				A rank	180	230	
Light current ratio		$\frac{I_L(1)}{I_L(3)}$	—	—	1.0	—	—
Dark current		I_{LEAK}	$V_{CC} = 3\text{ V}$, $E_V = 0$	—	—	0.2	μA
Saturation output voltage		V_O	$V_{CC} = 3\text{ V}$, $R_L = 75\text{ k}\Omega$, $E_V = 100\text{ lx}$ (Note 3)	2.2	2.35	2.6	V
Switching time	Rise time	t_r	$V_{CC} = 3\text{ V}$, $R_L = 5\text{ k}\Omega$, $V_{OUT} = 1.5\text{ V}$ (Note 6)	—	150	—	μs
	Fall time	t_f		—	300	—	
	Delay time	t_d		—	180	—	
	Storage time	t_s		—	8	—	

Note 2: CIE standard A light source is used (color temperature = 2856K, approximated incandescence light).

Note 3: F10 of fluorescence light is used as light source. (color temperature = 5000K)

However, white LED is substituted in a mass-production process.

Note 4: Light current measurement circuit

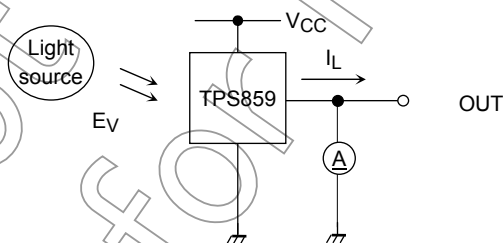

Note 5: Supply current measurement circuit

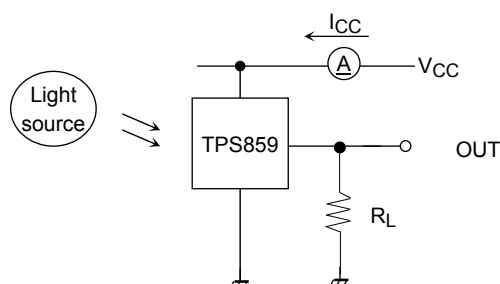

Note 6: Switching time measurement method

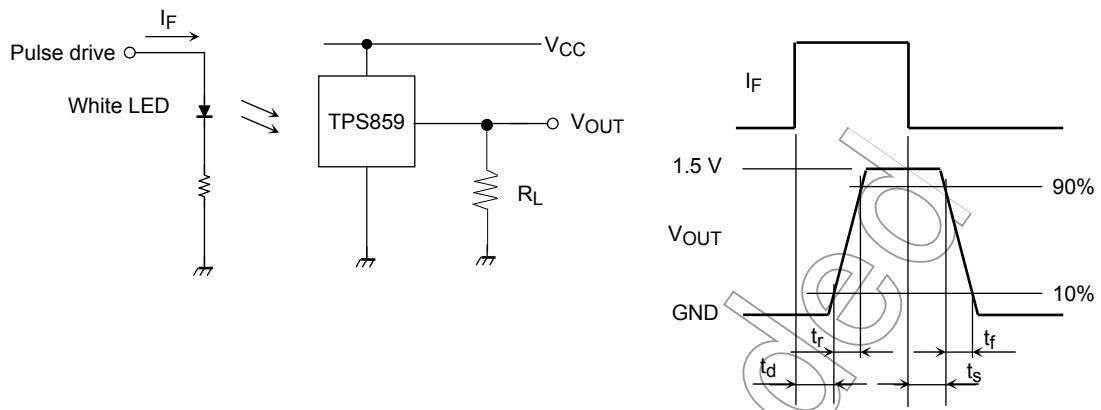

Not Recommended for New Design

Package Dimensions

0-2E1B

Unit: mm
 Tolerance: □0.1
 (): Reference value

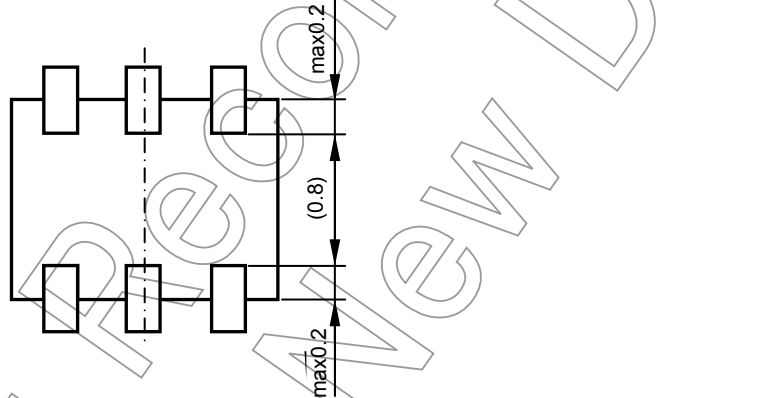
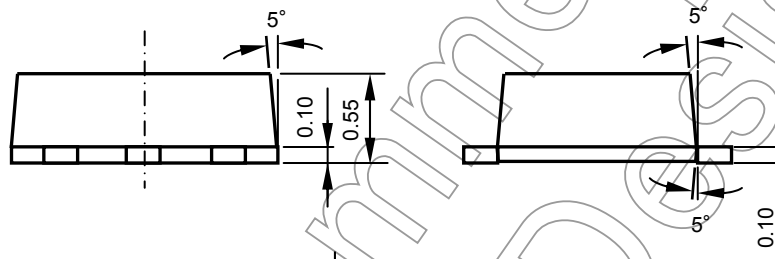
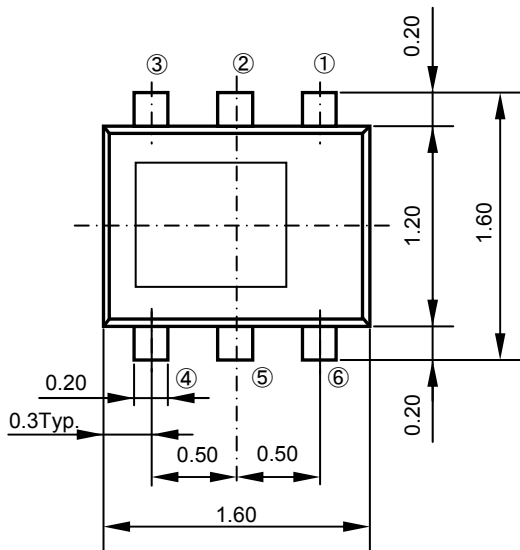

Pin connection

- 1. V_{CC}
- 2. GND
- 3. GND
- 4. GND
- 5. GND
- 6. OUT

Weight: 0.003 g (typ.)

Block Diagram

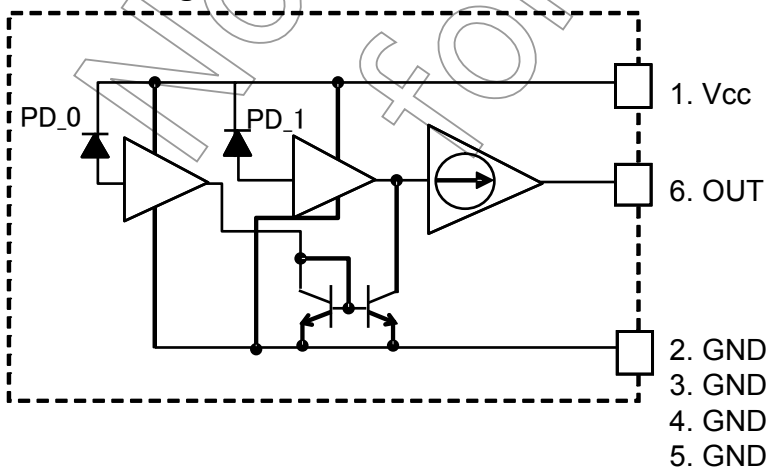

Equivalent circuit in output part

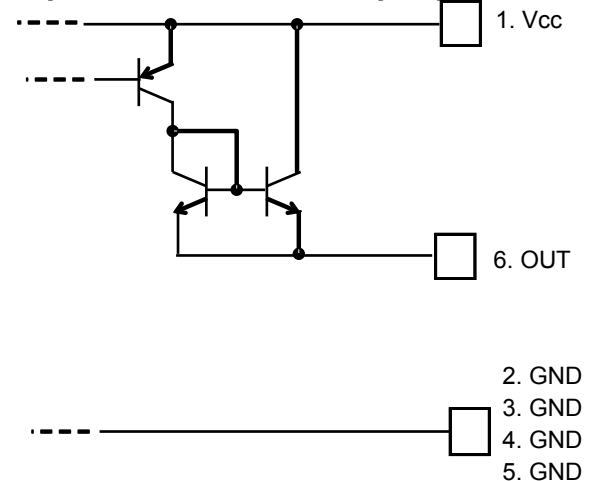

Handling Precautions

Insert a bypass condenser of up to 0.1 μ F between VCC and GND near the device to stabilize the power supply line.

Select a load resistor (R_L) that the load current (I_L) doesn't exceed the absolute maximum rating.

Calculation example of minimum load resistor: $R_L = (V_{CC} - V_{sat}) / I_L$ (Absolute maximum rating) = $(V_{CC} - 0.4V) / 4mA$

V_{sat} : (Supply voltage (V_{CC})) - (Maximum value of saturation output voltage) = 0.4V

V_{sat} is constant regardless of the supply voltage.

When Vcc is turned on it takes at least 200 ms for the internal circuit to stabilize. During this time the output signal is unstable. Please do not use the unstable signal as the output signal.

Moisture-Proof Packing

To avoid moisture absorption by the resin, the product is packed in an aluminum envelope with silica gel. Since the optical characteristics of the device can be affected during soldering by vaporization resulting from prior absorption of moisture and they should therefore be stored under the following conditions:

1. If the aluminum bag has been stored unopened
 - Temperature: 5 to 30°C
 - Relative humidity: 90% RH (max)
 - Time: 6 months
2. If the aluminum bag has been opened
 - Temperature: 5 to 30°C
 - Relative humidity: 70% RH (max)
 - Time: 168 h
3. Baking should be conducted within 72 h after the humidity indicator shows > 30% or the bag seal date is over 6 months. The number of baking should be once. If the baking is conducted repeatedly, it may affect the peel-back force and cause a problem for mounting.
 - Baking condition: 60 \pm 5°C, 12 to 24 h
 - Storage period: 6 months from the seal date on the label
4. When the photointerrupter is baked, protect it from electrostatic discharge.
5. Do not toss or drop to avoid damaging the moisture-proof bag.

Mounting Precautions

TPS859 uses a clear resin, and delicate handling is necessary for it.

The characteristic change or the product might be damaged by the handling method of mounting.

Please note the following and handle the product.

- (1) Do not apply stress to the resin at high temperature. Time until the product returns at the normal temperature after mounting of the reflow is different according to the mounting substrate and the environment. Please do not give the stress with heat remained in the product.
- (2) The resin part is easily scratched, so avoid friction with hard materials.
- (3) When installing the assembly board in equipment, ensure that this product does not come into contact with other components.
- (4) Please confirm the heat contraction of the substrate of the reflow mounting doesn't influence the product. The load is given to the product by mounting that the heat contraction is large on the substrate and the installation position of the substrate. Please note that the characteristic changes or the product might be damaged.

Mounting Methods

(1) Example of reflow soldering

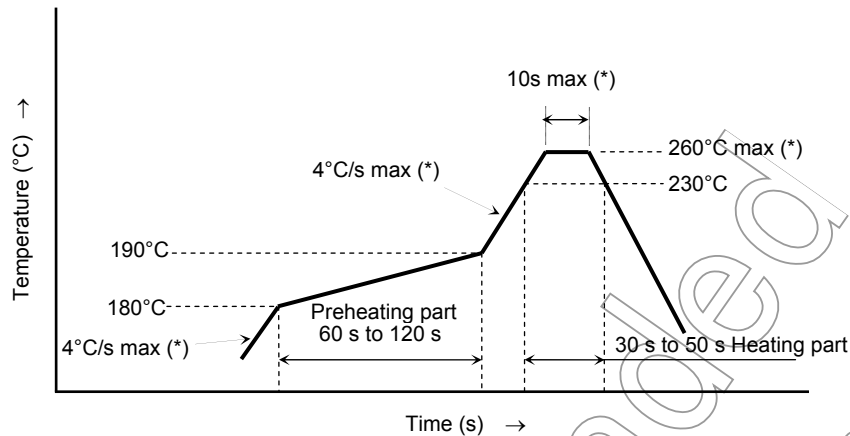

(*)The product is evaluated using above reflow soldering conditions. No additional test is performed exceed the condition (i.e. the condition more than MAX values) as an evaluation. Please perform reflow soldering under the above conditions. Perform reflow soldering no more than twice.

- Please perform the first reflow soldering within 168 h after opening the package with reference to the above temperature profile.
- Second reflow soldering
In case of second reflow soldering, it should be performed within 168 h after first reflow under the above conditions.
Storage conditions before second reflow soldering: 30°C, 70% RH or lower
- Do not perform flow soldering.
- Make any necessary soldering correction manually.
(Do not do this more than once for any given pin.)
Temperature: no more than 350°C (25 W for soldering iron)
Time: within 5 s

(2) Recommended soldering pattern

Unit: mm

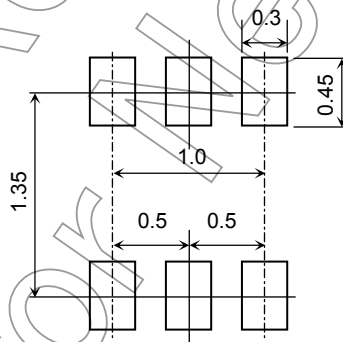

(3) Cleaning conditions

When cleaning is required after soldering
 Chemicals: AK225 alcohol
 Temperature and time: 50°C × 30 s or 30°C × 3 min
 Ultrasonic cleaning: 300 W or less

Packing Specification

(1) Packing quantity

Reel (minimum packing quantity)	3,000 devices
Carton	5 reels (15,000 devices)

(2) Packing format

An aluminum envelope containing silica gel and reels is deaerated and sealed.

Pack shock-absorbent materials around the aluminum envelopes in the cartons to cushion them.

- Carton specification

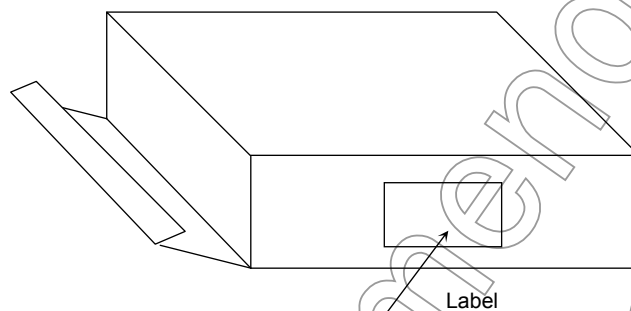

Carton dimensions

(W) 81 mm × (L) 280 mm × (H) 280 mm

Not Recommended for New Design

Tape Packing Specifications

- (3) Reel dimensions
Reel material: Plastic

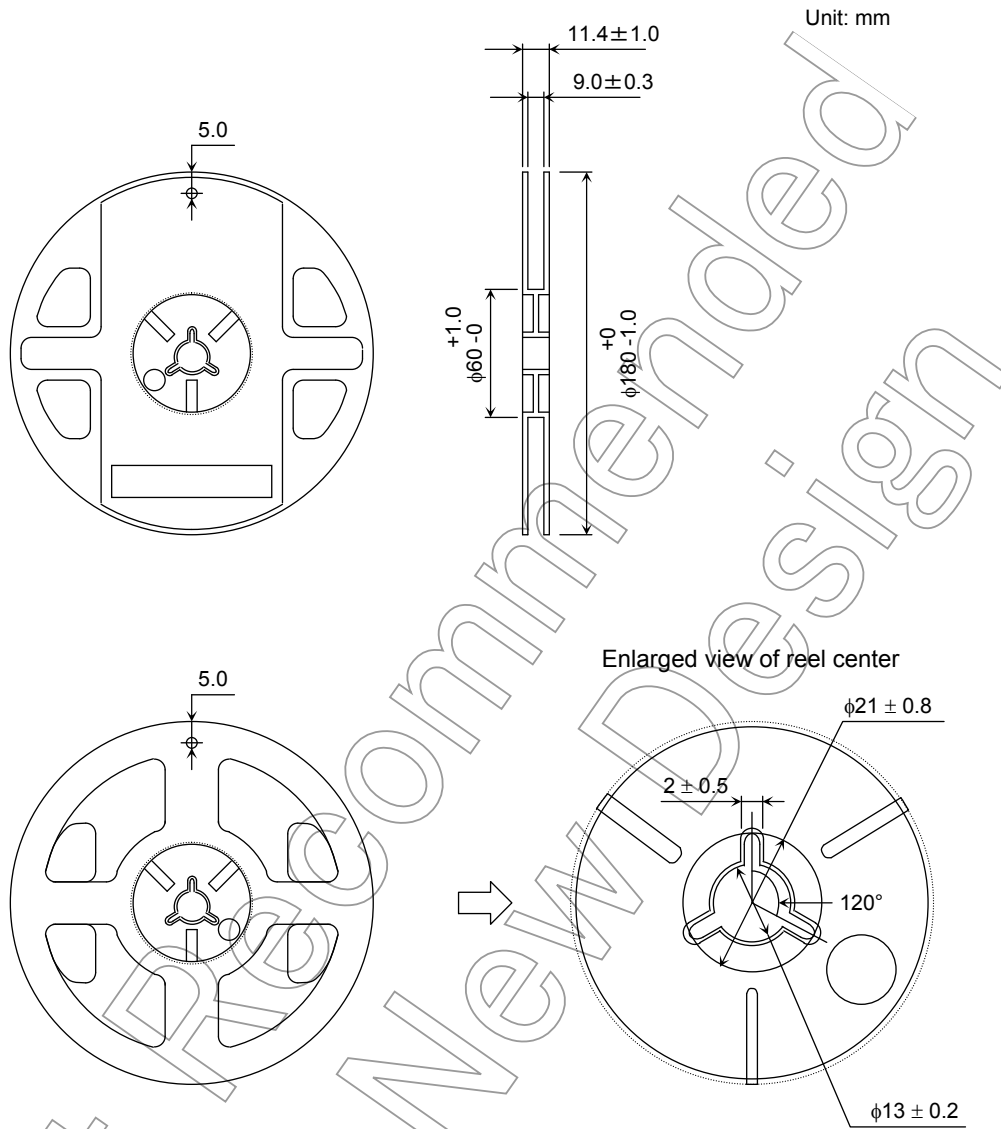

Not for New Design

(4) Tape dimensions
Tape material: Plastic (anti-electrostatic)

Unit: mm

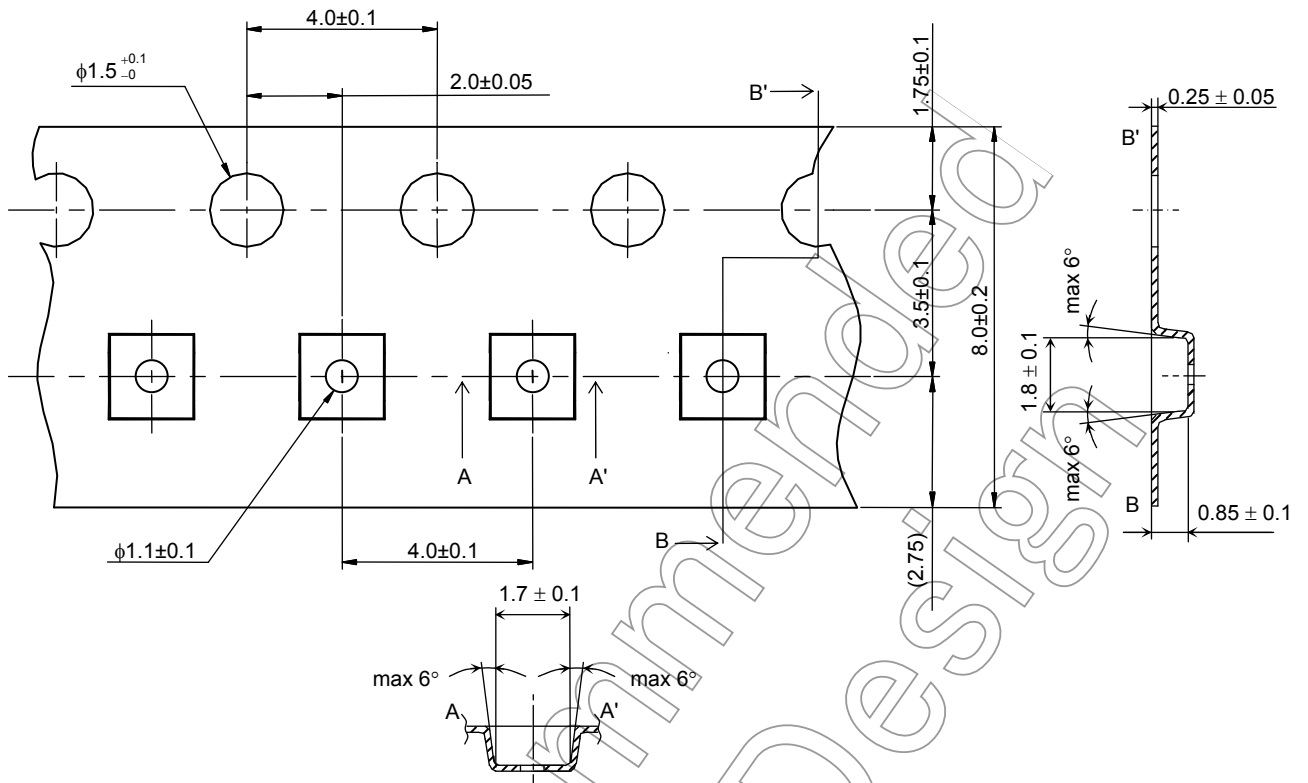

Product direction

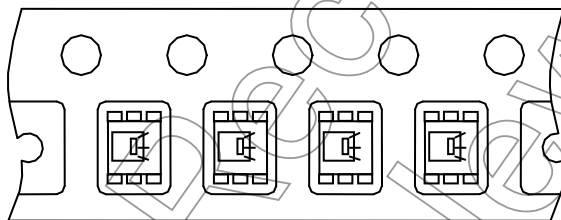

Not for Mouser Design

Reel Label

The label markings may include product number, quantity and seal date.

P/N

TYPE	TPS859		
ADDC		Q'TY	3,000 pcs.
NOTE			

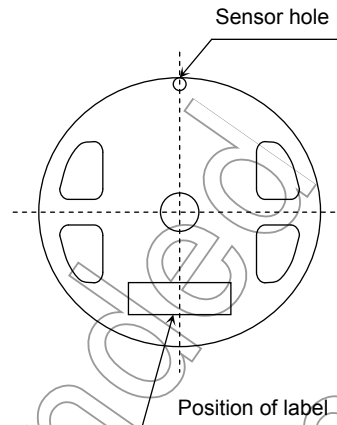

Leader and Trailer Sections of Tape

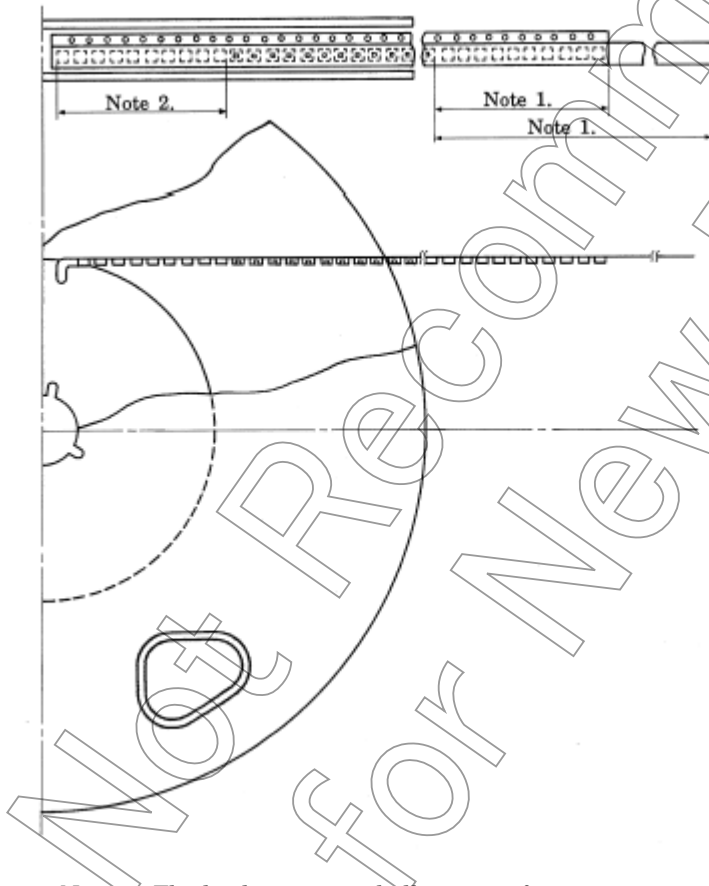

Note 1: The leader portion shall consist of cover tape minimum length of 300 mm and a piece of carrier tape with empty portion of 100 mm minimum.

Note 2: The trailer portion shall consist of empty carrier of more than 10 cavities.

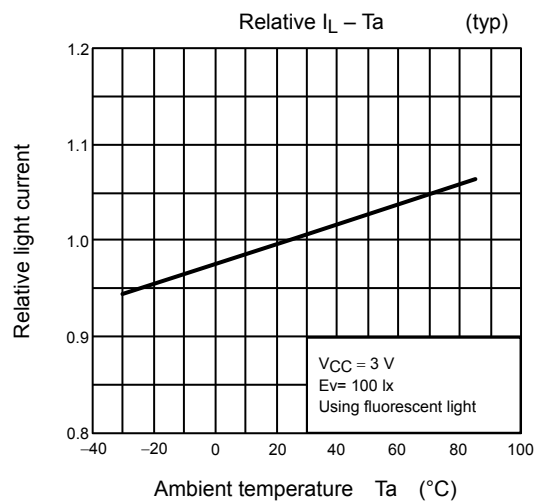
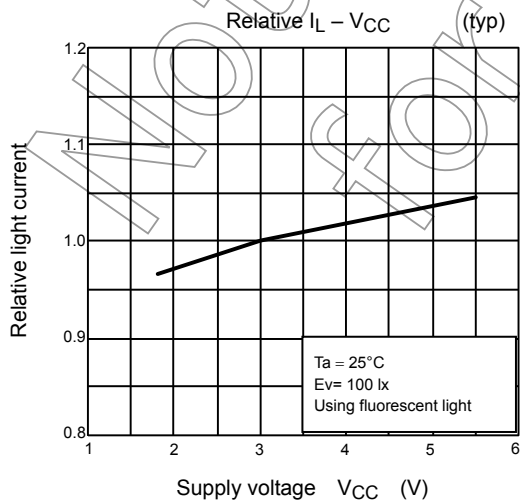
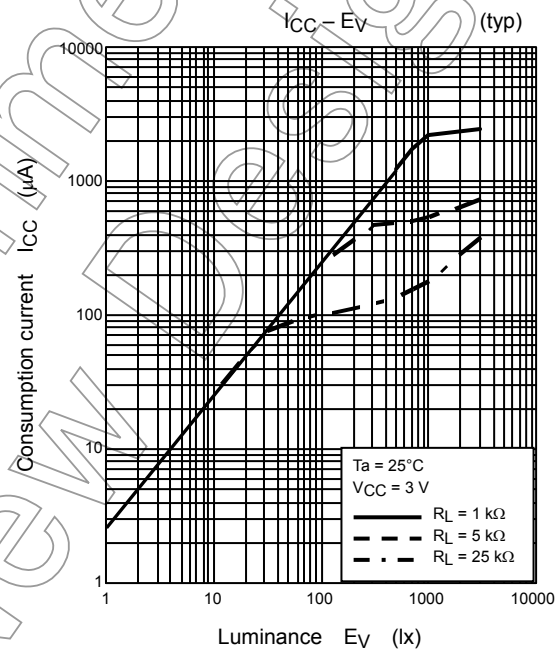
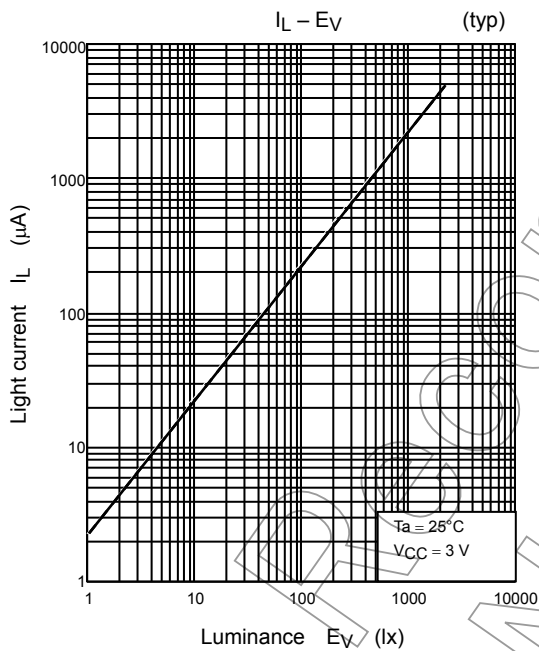
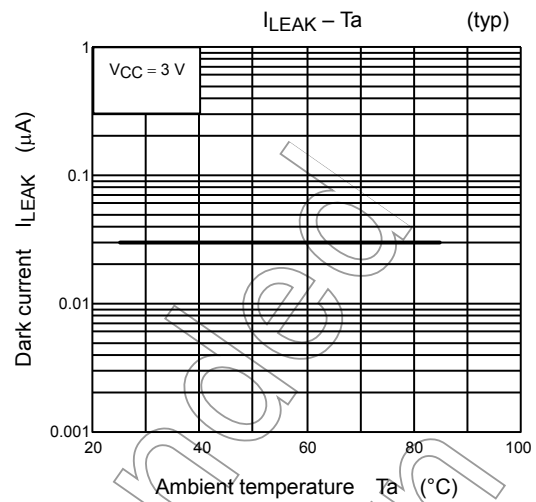
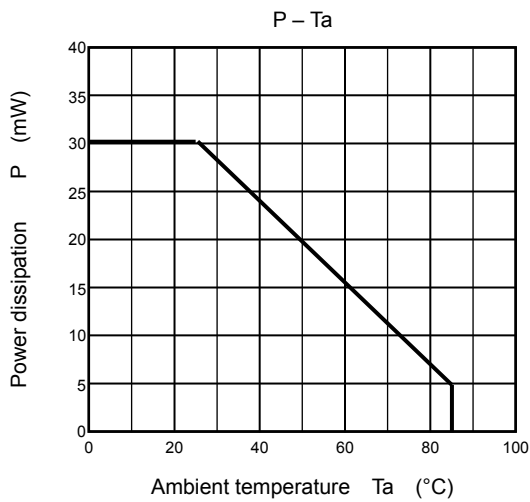

Switching Characteristics
(Non-saturating operation) (typ.)

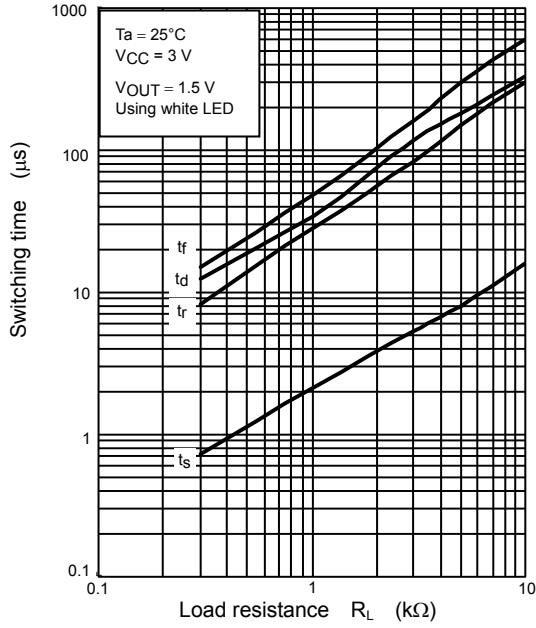

Switching Characteristics
(Saturating operation) (typ.)

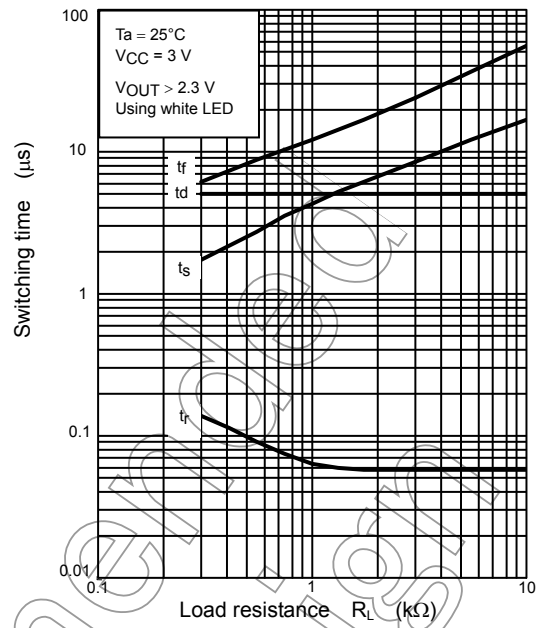

Spectral Response (typ.)

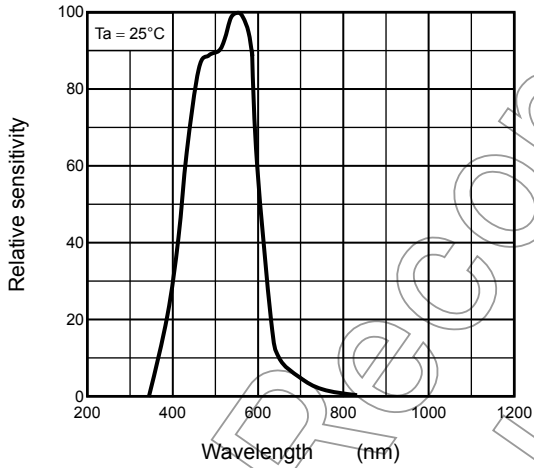

Radiation pattern (typ.)
 $T_a = 25^\circ\text{C}$

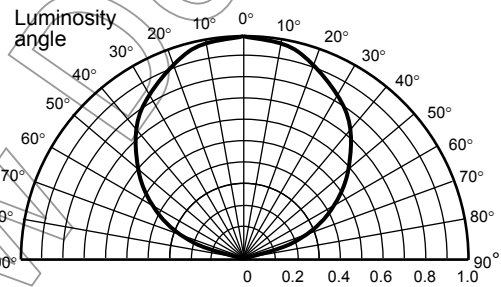

$V_{OUT} - E_V$ (typ.)

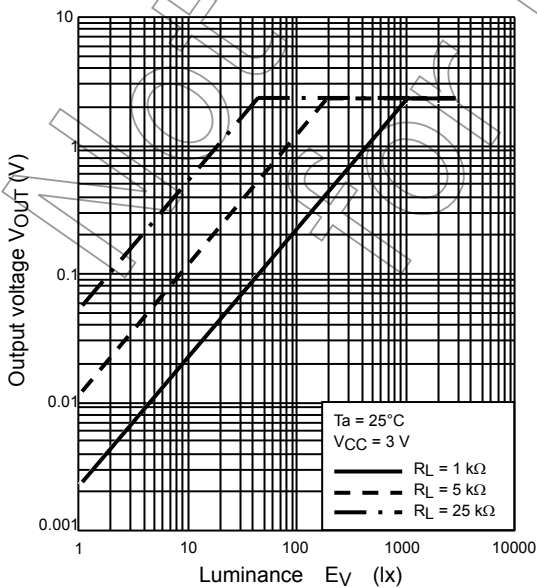

RESTRICTIONS ON PRODUCT USE

- Toshiba Corporation, and its subsidiaries and affiliates (collectively "TOSHIBA"), reserve the right to make changes to the information in this document, and related hardware, software and systems (collectively "Product") without notice.
- This document and any information herein may not be reproduced without prior written permission from TOSHIBA. Even with TOSHIBA's written permission, reproduction is permissible only if reproduction is without alteration/omission.
- Though TOSHIBA works continually to improve Product's quality and reliability, Product can malfunction or fail. Customers are responsible for complying with safety standards and for providing adequate designs and safeguards for their hardware, software and systems which minimize risk and avoid situations in which a malfunction or failure of Product could cause loss of human life, bodily injury or damage to property, including data loss or corruption. Before creating and producing designs and using, customers must also refer to and comply with (a) the latest versions of all relevant TOSHIBA information, including without limitation, this document, the specifications, the data sheets and application notes for Product and the precautions and conditions set forth in the "TOSHIBA Semiconductor Reliability Handbook" and (b) the instructions for the application that Product will be used with or for. Customers are solely responsible for all aspects of their own product design or applications, including but not limited to (a) determining the appropriateness of the use of this Product in such design or applications; (b) evaluating and determining the applicability of any information contained in this document, or in charts, diagrams, programs, algorithms, sample application circuits, or any other referenced documents; and (c) validating all operating parameters for such designs and applications. **TOSHIBA ASSUMES NO LIABILITY FOR CUSTOMERS' PRODUCT DESIGN OR APPLICATIONS.**
- Product is intended for use in general electronics applications (e.g., computers, personal equipment, office equipment, measuring equipment, industrial robots and home electronics appliances) or for specific applications as expressly stated in this document. Product is neither intended nor warranted for use in equipment or systems that require extraordinarily high levels of quality and/or reliability and/or a malfunction or failure of which may cause loss of human life, bodily injury, serious property damage or serious public impact ("Unintended Use"). Unintended Use includes, without limitation, equipment used in nuclear facilities, equipment used in the aerospace industry, medical equipment, equipment used for automobiles, trains, ships and other transportation, traffic signaling equipment, equipment used to control combustions or explosions, safety devices, elevators and escalators, devices related to electric power, and equipment used in finance-related fields. Do not use Product for Unintended Use unless specifically permitted in this document.
- Do not disassemble, analyze, reverse-engineer, alter, modify, translate or copy Product, whether in whole or in part.
- Product shall not be used for or incorporated into any products or systems whose manufacture, use, or sale is prohibited under any applicable laws or regulations.
- The information contained herein is presented only as guidance for Product use. No responsibility is assumed by TOSHIBA for any infringement of patents or any other intellectual property rights of third parties that may result from the use of Product. No license to any intellectual property right is granted by this document, whether express or implied, by estoppel or otherwise.
- **ABSENT A WRITTEN SIGNED AGREEMENT, EXCEPT AS PROVIDED IN THE RELEVANT TERMS AND CONDITIONS OF SALE FOR PRODUCT, AND TO THE MAXIMUM EXTENT ALLOWABLE BY LAW, TOSHIBA (1) ASSUMES NO LIABILITY WHATSOEVER, INCLUDING WITHOUT LIMITATION, INDIRECT, CONSEQUENTIAL, SPECIAL, OR INCIDENTAL DAMAGES OR LOSS, INCLUDING WITHOUT LIMITATION, LOSS OF PROFITS, LOSS OF OPPORTUNITIES, BUSINESS INTERRUPTION AND LOSS OF DATA, AND (2) DISCLAIMS ANY AND ALL EXPRESS OR IMPLIED WARRANTIES AND CONDITIONS RELATED TO SALE, USE OF PRODUCT, OR INFORMATION, INCLUDING WARRANTIES OR CONDITIONS OF MERCHANTABILITY, FITNESS FOR A PARTICULAR PURPOSE, ACCURACY OF INFORMATION, OR NONINFRINGEMENT.**
- Do not use or otherwise make available Product or related software or technology for any military purposes, including without limitation, for the design, development, use, stockpiling or manufacturing of nuclear, chemical, or biological weapons or missile technology products (mass destruction weapons). Product and related software and technology may be controlled under the Japanese Foreign Exchange and Foreign Trade Law and the U.S. Export Administration Regulations. Export and re-export of Product or related software or technology are strictly prohibited except in compliance with all applicable export laws and regulations.
- Please contact your TOSHIBA sales representative for details as to environmental matters such as the RoHS compatibility of Product. Please use Product in compliance with all applicable laws and regulations that regulate the inclusion or use of controlled substances, including without limitation, the EU RoHS Directive. TOSHIBA assumes no liability for damages or losses occurring as a result of noncompliance with applicable laws and regulations.