

809-002

#23 Electrical Socket Contact

For Series 79 Micro-Crimp and Series 80 Mighty Mouse



Special Purpose

Size #23 Crimp Socket Contact for Micro-Crimp and Mighty Mouse Connectors



Contact Type	Wire Size	Material	Part Number	Ø A		Color Band
				In.	mm.	
Socket	#22 – #28	BeCu	809-002	.0335-.0355	0.851-0.902	None
Socket	#26 – #30	BeCu	809-043	.0229-.0245	0.582-0.622	Blue
Socket	#22 – #28	Alumel	809-066A	.0335-.0355	0.851-0.902	None
Socket	#22 – #28	Chromel	809-066C	.0335-.0355	0.851-0.902	None

Standard size #23 contacts accept #22 to #28 AWG wire. Choose "small bore" versions for #26 to #30 AWG wire. For thermocouple applications, specify alumel or chromel contacts. Contacts are bulk packaged. Terminate with standard M22520 crimper with special positioner.

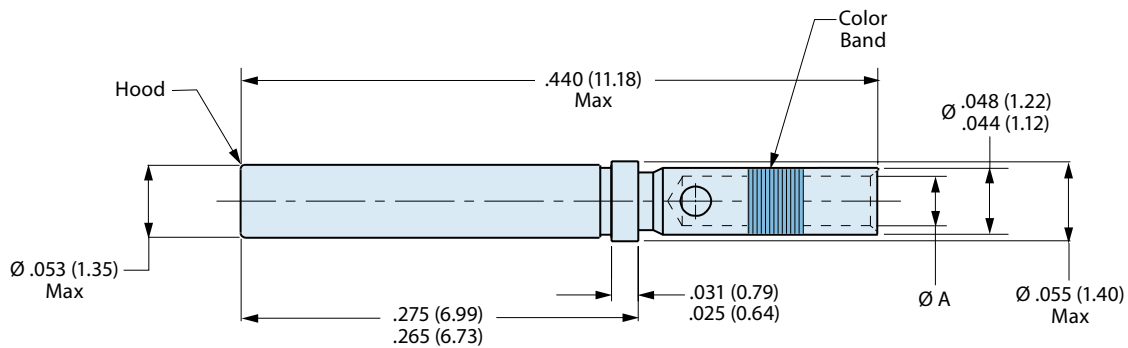

D

CRIMP TENSILE STRENGTH

Values are in pounds and are minimums.

Wire Gage	Silver or Tin Coated Copper Wire	Nickel Coated Copper Wire
#22	12	8
#24	8	6
#26	5	3
#28	3	2
#30	1.5	1.5

Material and Finish

Beryllium copper alloy per ASTM B196 or B197, 50 microinches gold plated per ASTM B488 Type 3 Code C Class 1,27 over nickel plate per QQ-N-290 Class 2, 50-100 microinches. Thermocouple contacts: alumel or chromel alloy, unplated, per ANSI 96.1 Socket contact hood: stainless steel, passivated per AMS-QQ-P-35.

Specifications

Current Rating: 5 Amps maximum
 Voltage Drop (at 5 Amps and 25° C): 70 millivolts maximum
 Temperature Range: -65° to + 200° C
 Socket Contact Minimum Separation Force: 0.5 ounces

Crimp Tools and Insertion/Extraction Tools

Crimper: 809-015 or AFM8
 Positioner: 809-005 (std). Use P/N 809-057 for small bore contacts 809-065 and 809-066
 Standard Insertion/Extraction Tool: 809-088