

2.1A Synchronous Current Boost DC/DC Regulator

General Description

The LP6250 is high efficiency Synchronous Boost DC/DC Converter, fixed frequency, current-mode step-up converter with output to input disconnect. A PWM step-up DC/DC converters optimized to provide a high efficiency solution to medium power system. Its PWM circuitry with built-in [2.1A@250mΩ](#) power mosfet makes this converter highly power efficiently. Selectable high switching frequency allows faster loop response and easy filtering with a low noise output. The non-inverting input its error amplifier is connected to an internal 0.5V precision reference voltage. Soft-start time can be programmed with an external capacitor, which sets the input current ramp rate. Current mode control and external compensation network make it easy and flexible to stabilize the system. the devices regulates the output voltage up to 5V from either a 2cell NiMH/NiCd or a single-cell Li-ion Battery with a 500KHz fixed frequency switching. These features minimize overall solution footprint by allowing the use of tiny, low profile inductors and ceramic capacitors.

Ordering Information

LP6250 - □ □ □

└───┬───┬───

F: Pb-Free

Package Type

QV: TDFN-10

Marking Information

Please see website.

Features

- ◆ Up to 94% efficiency
- ◆ Shut-down current:<1uA
- ◆ Output voltage Up to 5V
- ◆ 500KHz fixed frequency switching
- ◆ High switch on current:2.1A@250mΩ
- ◆ Available in TDFN-10 Package

Applications

- ◇ Battery products
- ◇ Host Products
- ◇ Motor Power Devices

Typical Application Circuit

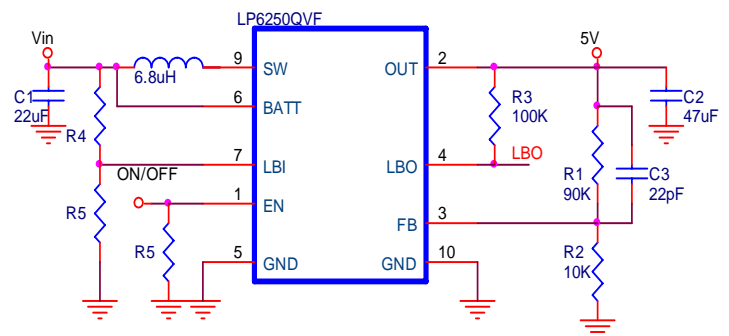

Pin Configurations

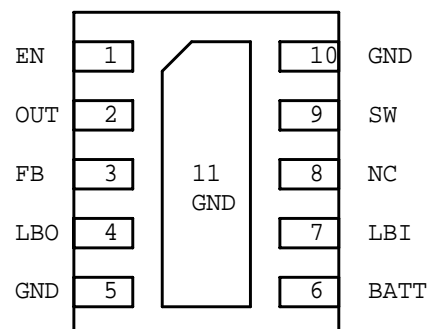

Functional Pin Description

PIN	PIN Name	Description
1	EN	Regulator On/off Control Input. A logic high input(VEN>1.4V) turns on the regulator. A logic low input(VEN<0.4V) puts the LP6250 into low current shutdown mode.
2	Out	Voltage output pin.
3	FB	Regulation Feedback Input. Connect to an external resistive voltage divider from the output to FB to set the output voltage.
4	LBO	Open-drain Low Battery Detector output pin.
5,10	GND	Power Ground.
6	BATT	Battery supply input pin.
7	LBI	Battery detector input pin.
8	NC	No Connector.
9	SW	Output switching node. SW is the drain of the internal N-Channel MOSFET and RDS-ON is 250mΩ. Connect the inductor to SW to Complete the step-up converter.
11	EPGND	Exposed PAD. Must connect to Ground.

Function Block Diagram

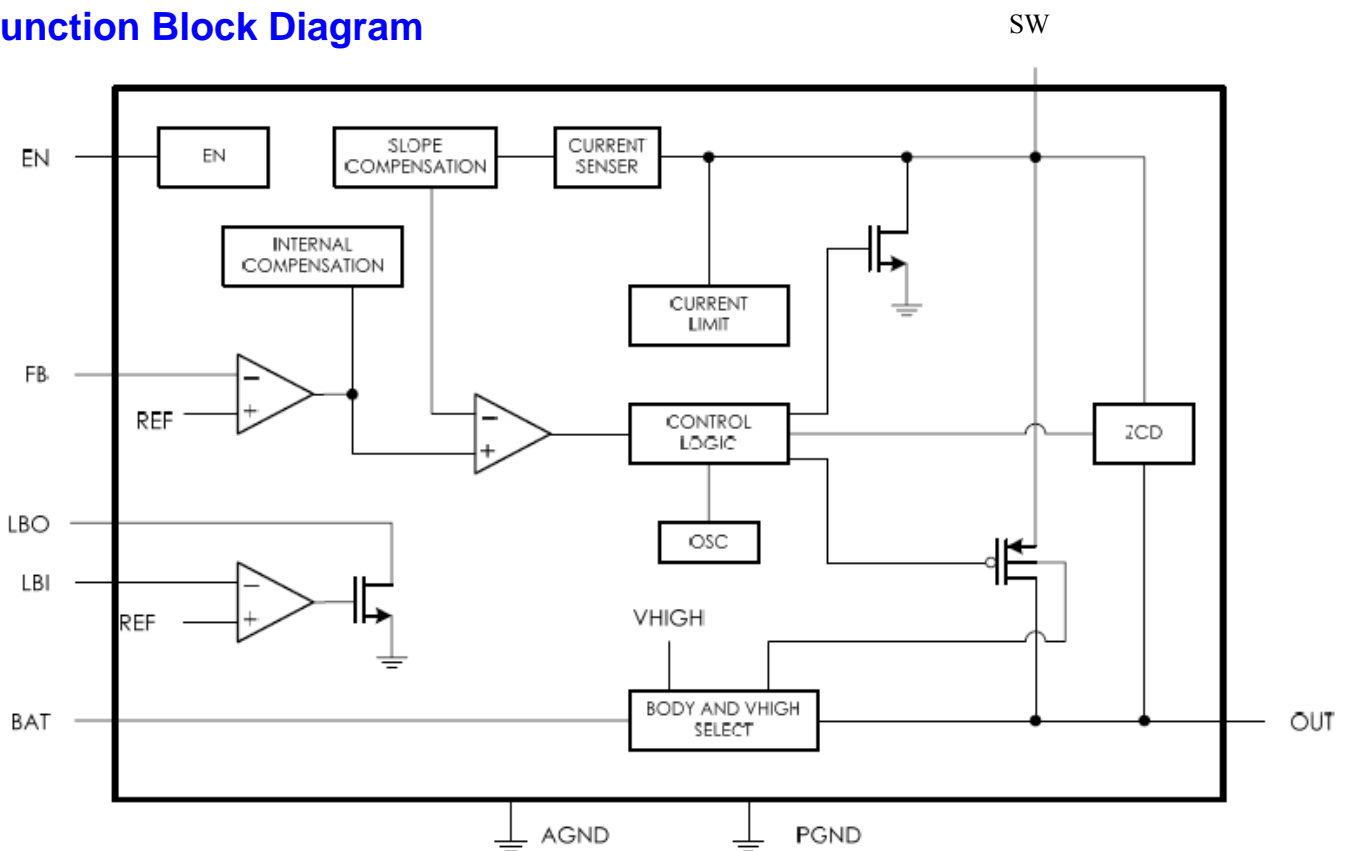

Absolute Maximum Ratings

Supply Input Voltage	-----6V
Power Dissipation, PD @ TA = 25° C	
TDFN-10	-----600mW
Lead Temperature (Soldering, 10 sec.)	-----260°C
Storage Temperature Range	----- -65°C to 150°C

Recommended Operating Conditions

Supply Input Voltage	----- 2.2V to 6V
SW Pin Voltage	----- 7V
EN Input Voltage	-----0V to 5.5V
Operation Junction Temperature Range	----- -40°C to 125°C
Operation Ambient Temperature Range	----- -40°C to 85°C

Electrical Characteristics

Parameter	Conditions	LP6250			Units
		Min	Typ.	Max	
Supply Voltage		2.2		5	V
Output Voltage Range		2.5		5	V
Supply Current(Shutdown)	VEN=VOUT=0V, VSW=5V		0.05	1	uA
Supply Current	VFB=1.3V		0.2		mA
Disable Supply Current	EN=GND		0.1		uA
Feedback Voltage			0.5		V
Feedback Input Current	VFB=1.2V		50		nA
Switching Frequency	FREQ		500		KHz
Maximum Duty Cycle		80	85	90	%
Low Battery Detector Input			0.5		V
EN Input Low Voltage				0.4	V
EN Input High Voltage		1.4			V
Mosfet On Resistance	Ron(N-mos)		235		mΩ
	Ron(P-mos)		250		mΩ
Mosfet Voltage(VDS)			14		V
NMOS Current Limit			2.1		A
Soft-start Reset Switch Resistance				100	Ω
Soft-start Input Source Current	VSS=1.2V		4.0		uA

Typical Operating Characteristics (VDD=3.3V,Vout=5V)

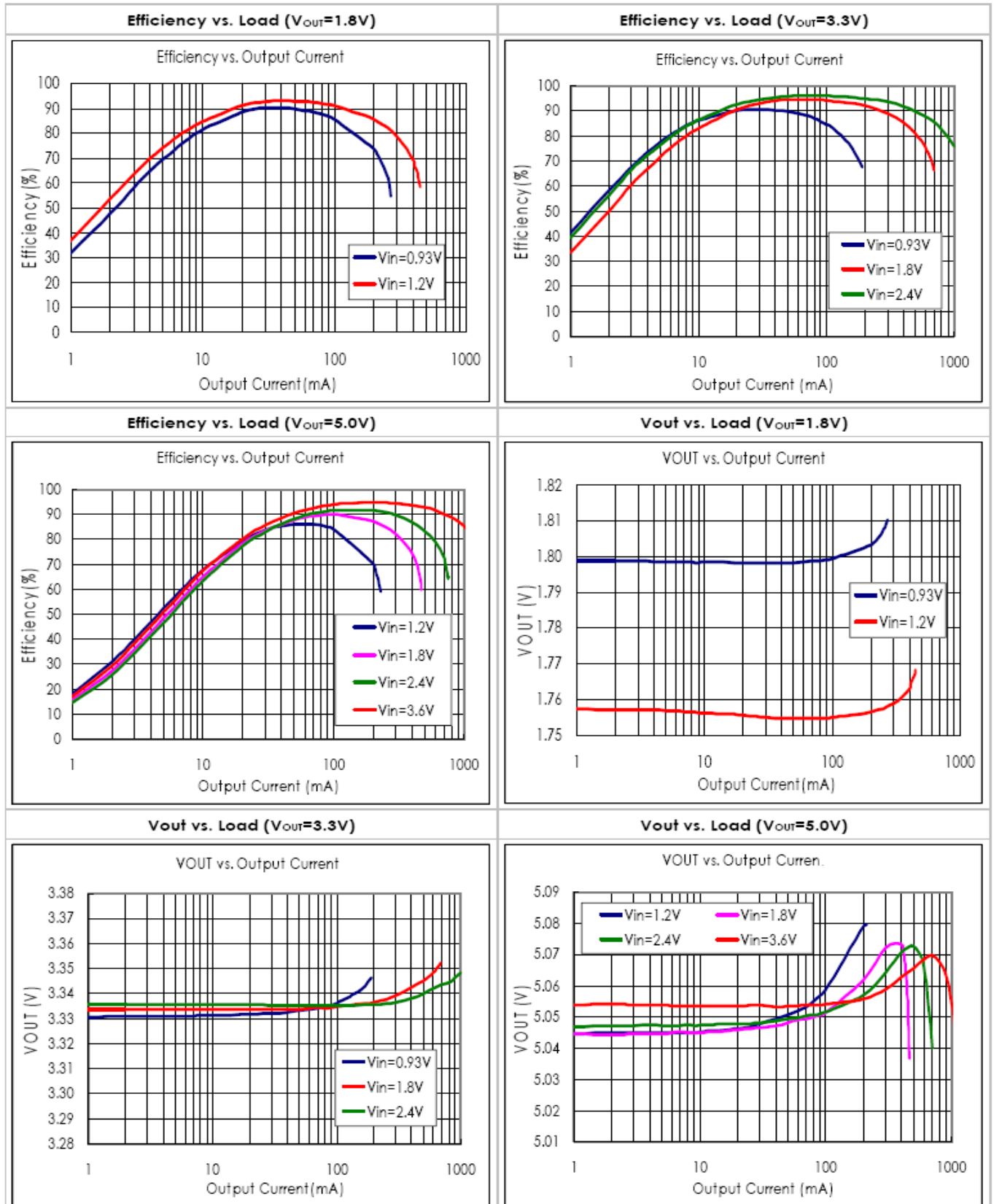

Load Transient ($V_{BAT}=1.2V$, $V_{OUT}=3.3V$, $I_{OUT}=100mA$ to $200mA$)

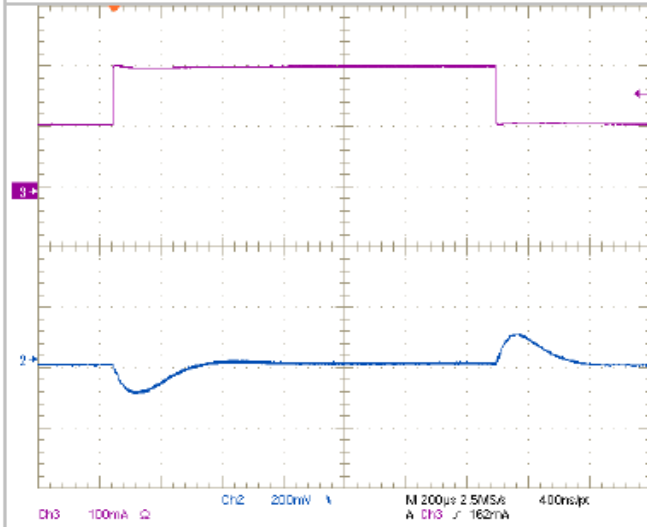

Load Transient ($V_{BAT}=3.6V$, $V_{OUT}=5.0V$, $I_{OUT}=100mA$ to $200mA$)

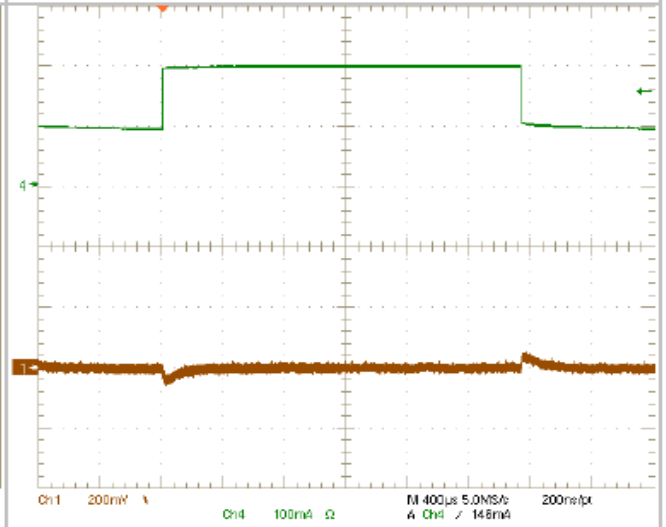

Line Transient ($V_{OUT}=3.3V$, $V_{BAT}=1.8V$ to $2.4V$, $I_{OUT}=100mA$)

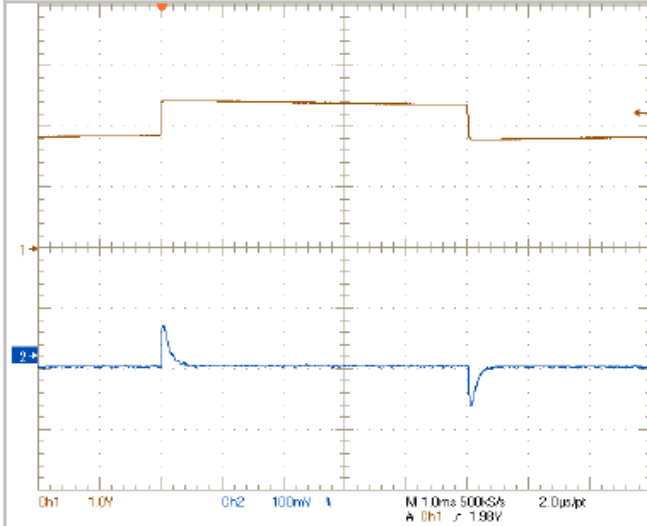

Line Transient ($V_{OUT}=5.0V$, $V_{BAT}=3.0V$ to $3.6V$, $I_{OUT}=200mA$)

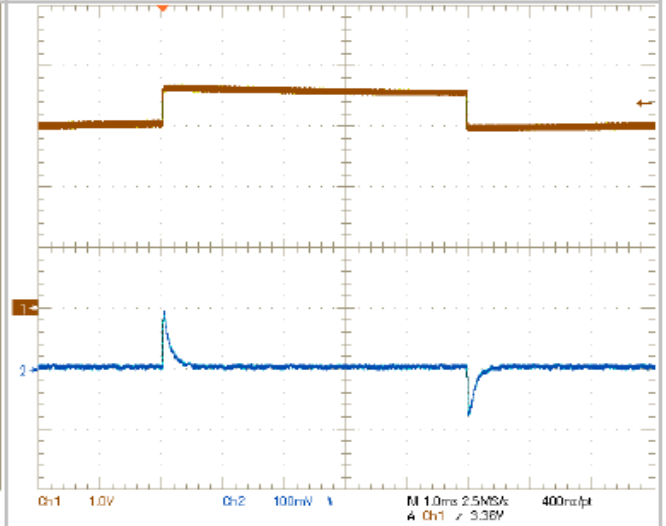

Start-Up ($V_{BAT}=2.4V$, $V_{OUT}=3.3V$)

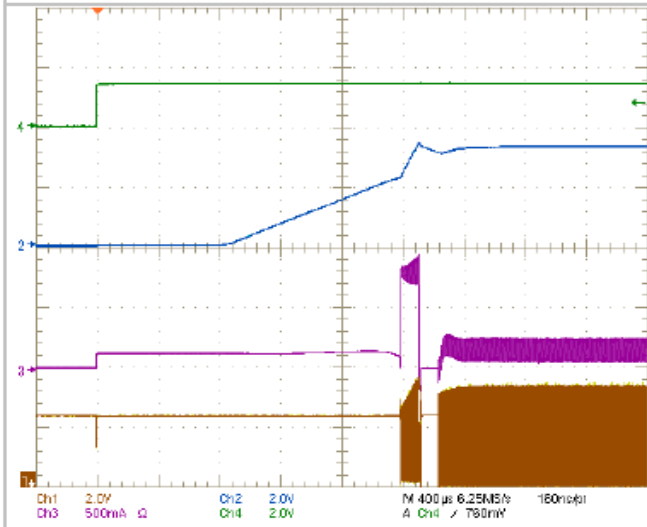

Start-Up ($V_{BAT}=3.6V$, $V_{OUT}=5.0V$)

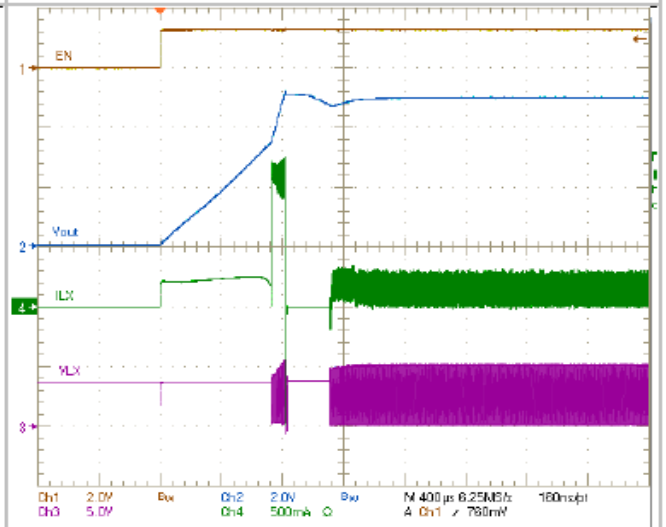

Operation Information

Output Voltage

The error amplifier compares a sample of the dc-dc converter output voltage with the 0.5V (VREF) reference and generates an error signal for the PWM comparator. Output voltage of dc-dc converter is setting with the resistor divider by the following equation:

$$V_{out} = (R1/R2 + 1) \times 0.5V$$

Oscillator

The switching frequency of LP6250 up to operate at either 500KHz.

Soft Start

The soft start is functional after power on. The interval of soft start time is determined by a capacitor connected to SS pin. When EN pin is taken high, the soft start capacitor (CSS) is charged by a constant current of 4 μ A (typ.). During this interval, the SS voltage directly controls the peak inductor current. The maximum load current is available after the soft-start interval is completed. Once the EN pin is taken low, the soft-start capacitor is discharged to ground to prepare for next start-up.

The load must wait for the soft-start interval to finish before drawing a significant amount of load current. The duration after which the load can begin to draw maximum load current is:

$$T_{MAX} = 6.77 \times 10^5 C_{SS}$$

EN

The LP6250 can be turn off to reduce the supply current to 0.1 μ A when EN is low. In this mode, the internal reference, error amplifier, comparators, and biasing circuitry turn off while the N-channel MOSFET is turned off. The boost converter's output is connected to VCC by the external inductor and catch diode.

Output Current Capability

The output current capability of the LP6250 is a function of current limit, input voltage, operation frequency, and inductor value. Because of the slope compensation used to stabilize the feedback loop, the duty cycle affects the current limit. The output

current capability is governed by the following equation:

$$I_{OUT(MAX)} = [(LIM \times (1.26 - 0.4 \times Duty) - 0.5 \times Duty \times V_{IN} / (f_{OSC} \times L))] \times \eta \times V_{IN} / V_{OUT}$$

Current Limitation

The internal power-MOS switch current is monitored cycle-by-cycle and is limited to the value not exceed 2.1A (Typ.). When the switch current reaches the limited value, the internal power-MOS is turned off immediately until the next cycle.

Low Battery Detector

The LP6250 provides an on-chip comparator with 35mV internal hysteresis for low battery detection. If the LBI pin voltage falls below the internal reference voltage(0.5V), the LBO pin (an open-drain output) sinks current to GND. The LBI pin should be connected to BAT pin if the low battery comparator is not used.

Layout considerations

Typical for all switching power supplies, the layout is an important step in the design; especially at high peak-currents and switching frequencies. If the layout is not carefully done, the regulator might show noise problem and duty cycle fitter. The input capacitor should be placed as close as possible to the input pin for good input voltage viltering. The inductor and diode should be placed as close as possible to the switch pin to minimize the noise coupling in to other circuits. Since the feedback pin and network is a high impedance circuit the feedback network should be routed away from the inductor. The feedback pin and feedback network should be shielded with a ground plane or trace to minimize noise coupling into this circuit.

Application Circuit Information

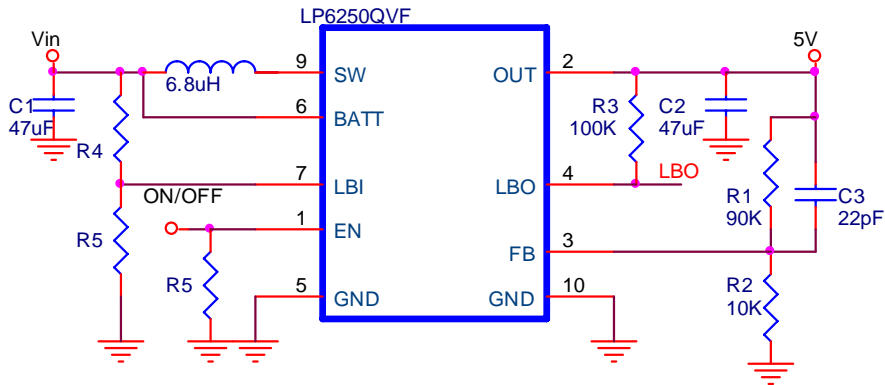

Figure1. LP6250 application circuit of used Low Battery Circuit

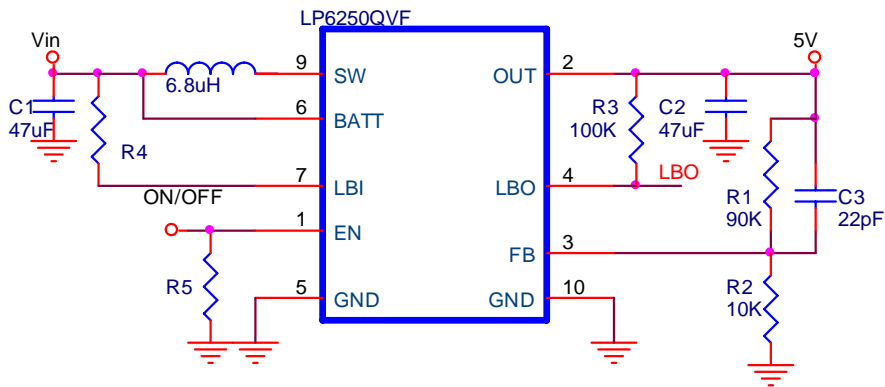
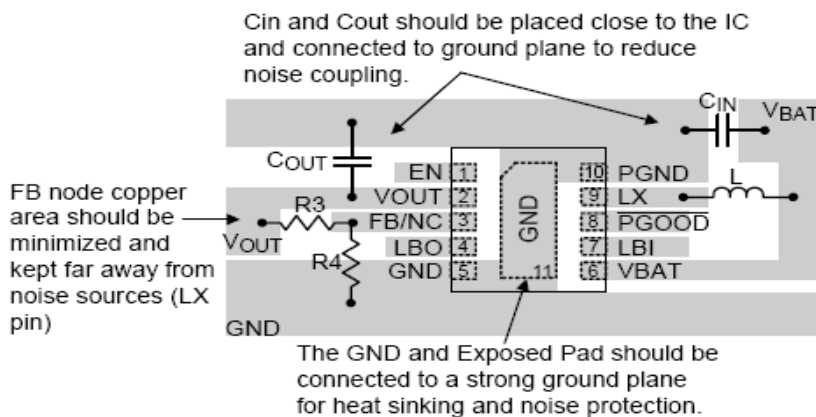
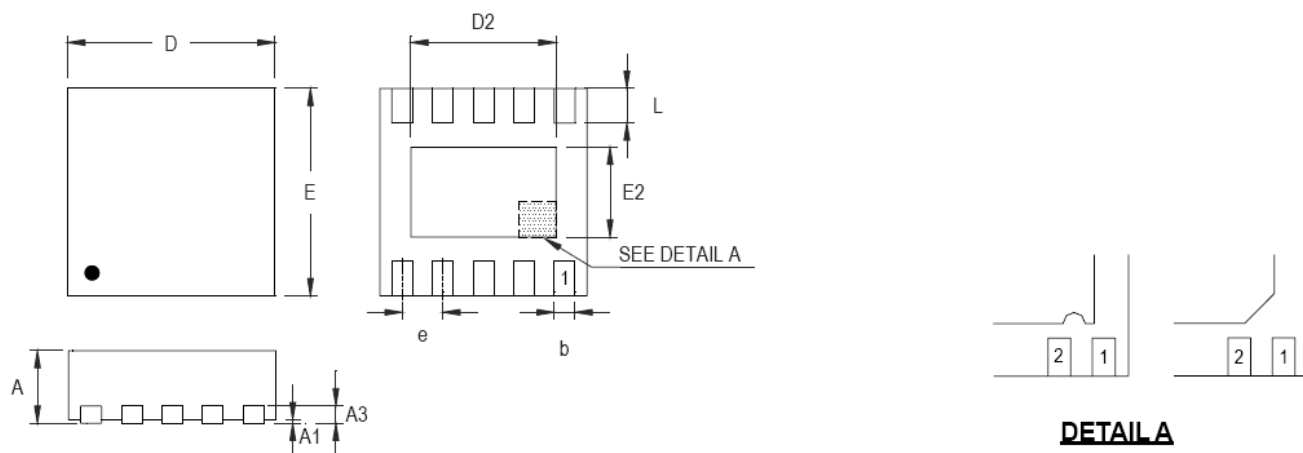

Figure2. LP6250 application of not used Low Battery Circuit

Layout Circuit Information



Packaging Information



DETAIL A

Pin #1 ID and Tie Bar Mark Options

Note : The configuration of the Pin #1 identifier is optional, but must be located within the zone indicated.

Symbol	Dimensions In Millimeters		Dimensions In Inches	
	Min	Max	Min	Max
A	0.700	0.800	0.028	0.031
A1	0.000	0.050	0.000	0.002
A3	0.175	0.250	0.007	0.010
b	0.180	0.300	0.007	0.012
D	2.950	3.050	0.116	0.120
D2	2.300	2.650	0.091	0.104
E	2.950	3.050	0.116	0.120
E2	1.500	1.750	0.059	0.069
e	0.500		0.020	
L	0.350	0.450	0.014	0.018

W-Type 10L DFN 3x3 Package