



SGM8621/2/3/4 250µA, 3MHz, Rail-to-Rail I/O CMOS Operational Amplifiers

PRODUCT DESCRIPTION

The SGM8621 (single), SGM8622 (dual), SGM8623 (single with shutdown) and SGM8624 (quad) are low noise, low voltage, and low power operational amplifiers, that can be designed into a wide range of applications. The SGM8621/2/3/4 have a high gain-bandwidth product of 3MHz, a slew rate of 1.7V/µs, and a quiescent current of 250µA/amplifier at 5V. The SGM8623 has a power-down disable feature that reduces the supply current to 150nA.

The SGM8621/2/3/4 are designed to provide optimal performance in low voltage and low noise systems. They provide rail-to-rail output swing into heavy loads. The input common mode voltage range includes ground, and the maximum input offset voltage is 3mV for SGM8621/2/3/4. They are specified over the extended industrial temperature range (-40°C to +125°C). The operating range is from 2.5V to 5.5V.

The single version, SGM8621/8623, is available in Green SC70-5, SOIC-8 and SOT-23-5(6) packages. The dual version SGM8622 is available in Green SOIC-8 and MSOP-8 packages. The quad version SGM8624 is available in Green SOIC-14 and TSSOP-14 packages.

APPLICATIONS

- Sensors
- Audio
- Active Filters
- A/D Converters
- Communications
- Test Equipment
- Cellular and Cordless Phones
- Laptops and PDAs
- Photodiode Amplification
- Battery-Powered Instrumentation

FEATURES

- **Low Cost**
- **Rail-to-Rail Input and Output**
0.7mV Typical V_{OS}
- **High Gain-Bandwidth Product: 3MHz**
- **High Slew Rate: 1.7V/µs**
- **Settling Time to 0.1% with 2V Step: 2.1µs**
- **Overload Recovery Time: 1µs**
- **Low Noise: 12nV/√Hz**
- **Supply Voltage Range: 2.5V to 5.5V**
- **Input Voltage Range: -0.1V to +5.6V with $V_S = 5.5V$**
- **Low Supply Current**
250µA/Amplifier (TYP)
150nA Shutdown Current for SGM8623
- **Small Packaging**
SGM8621 Available in SC70-5, SOT-23-5 and SOIC-8
SGM8622 Available in MSOP-8 and SOIC-8
SGM8623 Available in SOT-23-6 and SOIC-8
SGM8624 Available in TSSOP-14 and SOIC-14

PIN CONFIGURATIONS (TOP VIEW)

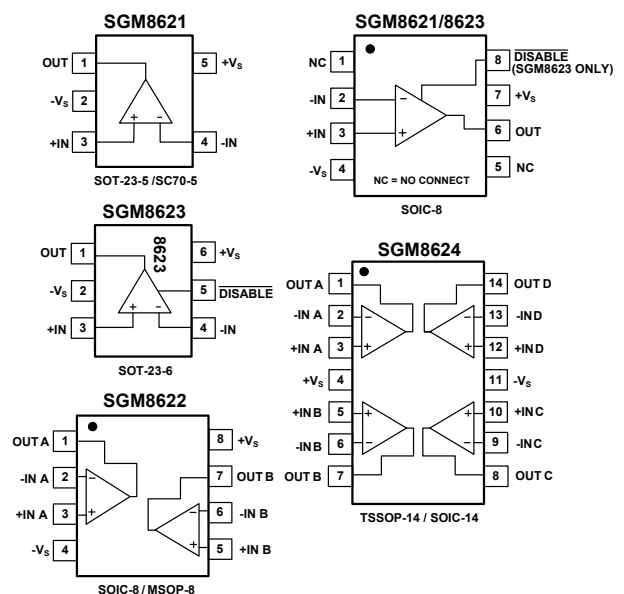

PACKAGE/ORDERING INFORMATION

MODEL	ORDER NUMBER	PACKAGE DESCRIPTION	PACKAGE OPTION	MARKING INFORMATION
SGM8621	SGM8621XC5/TR	SC70-5	Tape and Reel, 3000	8621
	SGM8621XN5/TR	SOT-23-5	Tape and Reel, 3000	8621
	SGM8621XS/TR	SOIC-8	Tape and Reel, 2500	SGM8621XS
SGM8622	SGM8622XMS/TR	MSOP-8	Tape and Reel, 3000	SGM8622XMS
	SGM8622XS/TR	SOIC-8	Tape and Reel, 2500	SGM8622XS
SGM8623	SGM8623XN6/TR	SOT-23-6	Tape and Reel, 3000	8623
	SGM8623XS/TR	SOIC-8	Tape and Reel, 2500	SGM8623XS
SGM8624	SGM8624XS14/TR	SOIC-14	Tape and Reel, 2500	SGM8624XS14
	SGM8624XTS14/TR	TSSOP-14	Tape and Reel, 3000	SGM8624XTS14

ABSOLUTE MAXIMUM RATINGS

Supply Voltage, +V _S to -V _S	7.5V	SOT-23-6, θ_{JA}	190°C/W
Common Mode Input Voltage.....	(-V _S) - 0.5V to (+V _S) + 0.5V	SOIC-8, θ_{JA}	125°C/W
Storage Temperature Range.....	-65°C to +150°C	MSOP-8, θ_{JA}	216°C/W
Junction Temperature.....	160°C	Lead Temperature (Soldering 10sec)	
Operating Temperature Range.....	-55°C to +150°C	260°C
Package Thermal Resistance @ T _A = +25°C		ESD Susceptibility	
SC70-5, θ_{JA}	333°C/W	HBM.....	1500V
SOT-23-5, θ_{JA}	190°C/W	MM.....	400V

NOTE:

Stresses beyond those listed under "Absolute Maximum Ratings" may cause permanent damage to the device. These are stress ratings only, and functional operation of the device at these or any other conditions beyond those indicated in the operational sections of the specifications is not implied. Exposure to absolute maximum rating conditions for extended periods may affect device reliability.

CAUTION

This integrated circuit can be damaged by ESD if you don't pay attention to ESD protection. SGMICRO recommends that all integrated circuits be handled with appropriate precautions. Failure to observe proper handling and installation procedures can cause damage. ESD damage can range from subtle performance degradation to complete device failure. Precision integrated circuits may be more susceptible to damage because very small parametric changes could cause the device not to meet its published specifications.

SGMICRO reserves the right to make any change in circuit design, specification or other related things if necessary without notice at any time. Please contact SGMICRO sales office to get the latest datasheet.

ELECTRICAL CHARACTERISTICS: $V_S = +5V$ (At $T_A = +25^\circ\text{C}$, $V_{CM} = V_S/2$, $R_L = 600\Omega$, unless otherwise noted.)

PARAMETER	CONDITIONS	SGM8621/2/3/4							
		TYP	MIN/MAX OVER TEMPERATURE					UNITS	MIN/MAX
		+25°C	+25°C	0°C to 70°C	-40°C to 85°C	-40°C to 125°C			
INPUT CHARACTERISTICS									
Input Offset Voltage (V_{OS})		0.7	3	3.1	3.3	3.5	mV	MAX	
Input Bias Current (I_B)		1					pA	TYP	
Input Offset Current (I_{OS})		1					pA	TYP	
Input Common Mode Voltage Range (V_{CM})	$V_S = 5.5V$	-0.1 to +5.6					V	TYP	
Common Mode Rejection Ratio (CMRR)	$V_S = 5.5V, V_{CM} = -0.1V$ to 4V	90	75	74	73	73	dB	MIN	
	$V_S = 5.5V, V_{CM} = -0.1V$ to 5.6V	92	66	65	65	64	dB	MIN	
Open-Loop Voltage Gain (A_{OL})	$R_L = 600\Omega, V_O = 0.15V$ to 4.85V	100	92	90	89	78	dB	MIN	
	$R_L = 10k\Omega, V_O = 0.05V$ to 4.95V	110	100	99	98	82	dB	MIN	
Input Offset Voltage Drift ($\Delta V_{OS}/\Delta T$)		2.7					$\mu\text{V}/^\circ\text{C}$	TYP	
OUTPUT CHARACTERISTICS									
Output Voltage Swing from Rail	$R_L = 600\Omega$	0.1					V	TYP	
	$R_L = 10k\Omega$	0.015					V	TYP	
Output Current (I_{OUT})		48	45	42	40	30	mA	MIN	
Closed-Loop Output Impedance	$f = 100\text{kHz}, G = +1$	2.6					Ω	TYP	
POWER-DOWN DISABLE (SGM8623 ONLY)									
Turn-On Time		6.2					ns	TYP	
Turn-Off Time		1.4					ns	TYP	
$\overline{\text{DISABLE}}$ Voltage-Off			0.8				V	MAX	
$\overline{\text{DISABLE}}$ Voltage-On			2				V	MIN	
POWER SUPPLY									
Operating Voltage Range			2.5	2.5	2.5	2.5	V	MIN	
			5.5	5.5	5.5	5.5	V	MAX	
Power Supply Rejection Ratio (PSRR)	$V_S = +2.5V$ to +5.5V $V_{CM} = (-V_S) + 0.5V$	94	79	78	77	76	dB	MIN	
Quiescent Current/Amplifier (I_Q)	$I_{OUT} = 0$	250	300	345	350	380	μA	MAX	
Supply Current when Disabled (SGM8623 only)		150					nA	MAX	
DYNAMIC PERFORMANCE									
Gain-Bandwidth Product (GBP)	$R_L = 10k\Omega$	3					MHz	TYP	
Phase Margin (ϕ_O)		67					Degrees	TYP	
Full Power Bandwidth (BW_P)	< 1% distortion, $R_L = 600\Omega$	50					kHz	TYP	
Slew Rate (SR)	$G = +1, 2V$ step, $R_L = 10k\Omega$	1.7					$\text{V}/\mu\text{s}$	TYP	
Settling Time to 0.1% (t_S)	$G = +1, 2V$ step, $R_L = 600\Omega$	2.1					μs	TYP	
Overload Recovery Time	$V_{IN} \cdot \text{Gain} = V_S, R_L = 600\Omega$	1					μs	TYP	
NOISE PERFORMANCE									
Voltage Noise Density (e_n)	$f = 1\text{kHz}$	12					$\text{nV}/\sqrt{\text{Hz}}$	TYP	
Current Noise Density (i_n)	$f = 1\text{kHz}$	3					$\text{fA}/\sqrt{\text{Hz}}$	TYP	

TYPICAL PERFORMANCE CHARACTERISTICS

At $T_A = +25^\circ\text{C}$, $V_{CM} = V_S/2$, $R_L = 600\Omega$, unless otherwise noted.

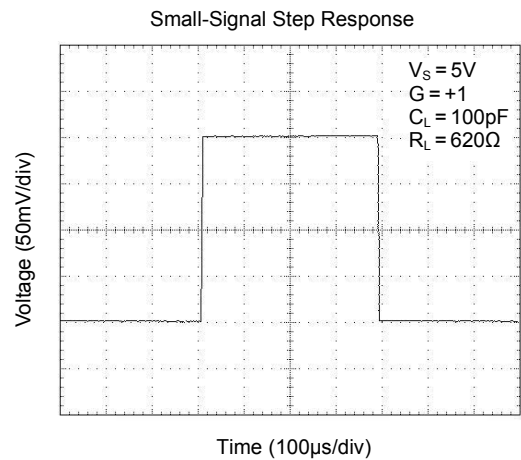
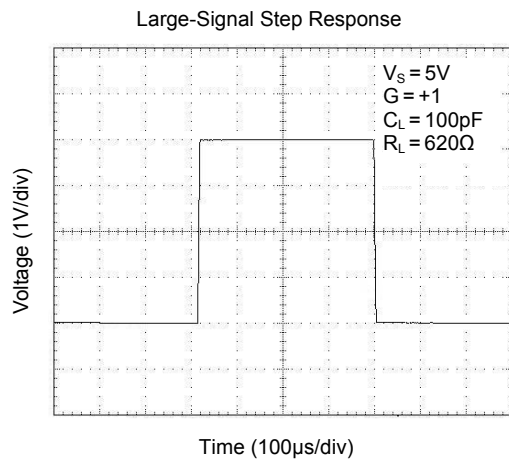
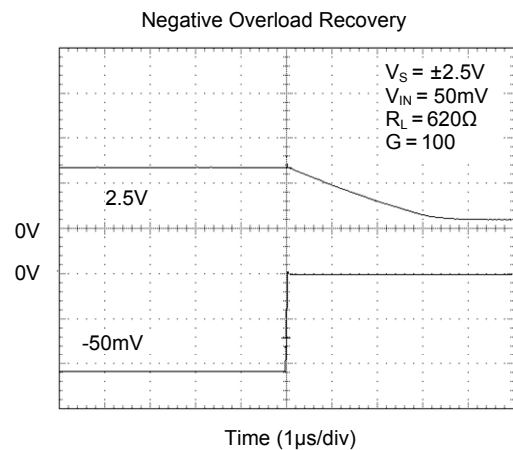
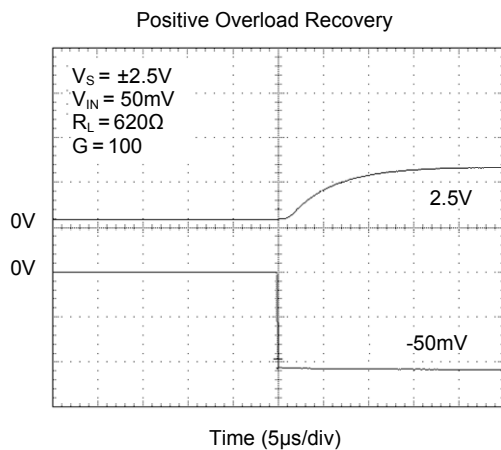
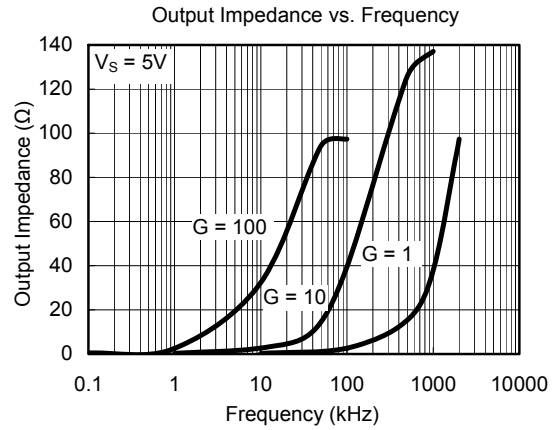
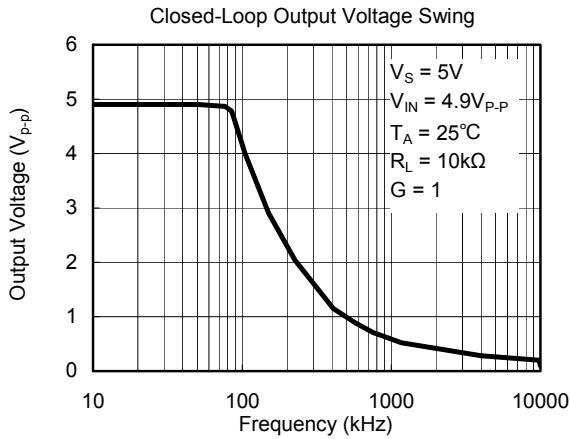

TYPICAL PERFORMANCE CHARACTERISTICS

At $T_A = +25^\circ\text{C}$, $V_{CM} = V_S/2$, $R_L = 600\Omega$, unless otherwise noted.

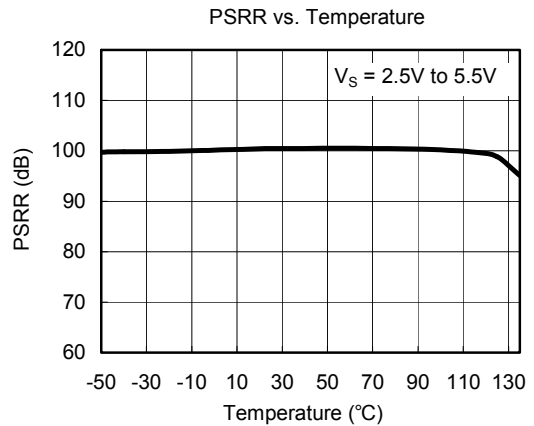
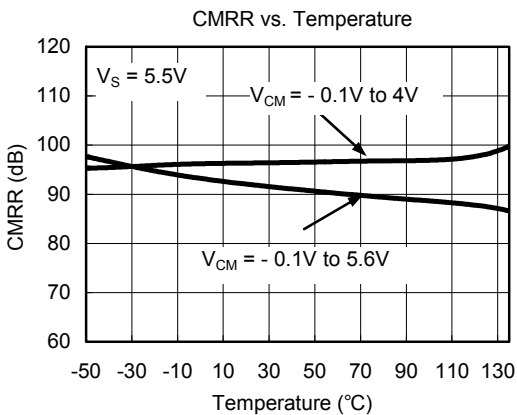
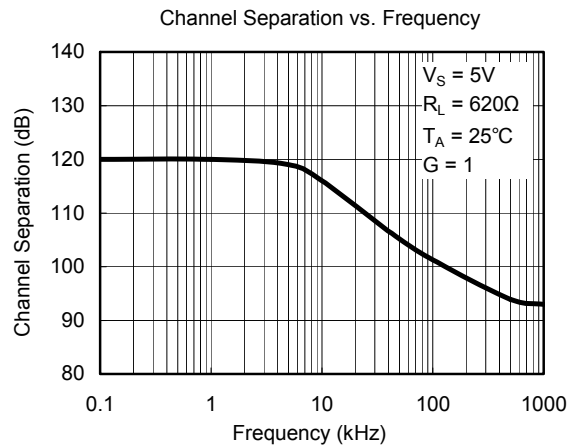
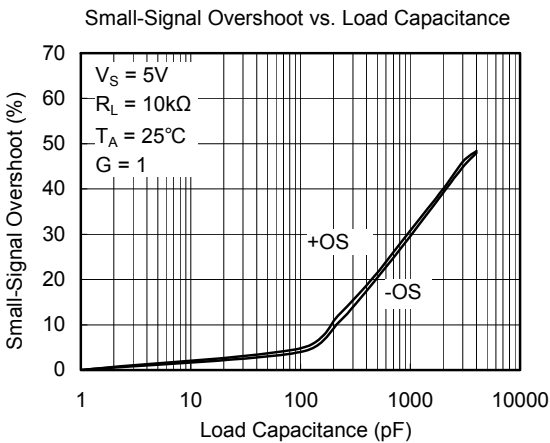
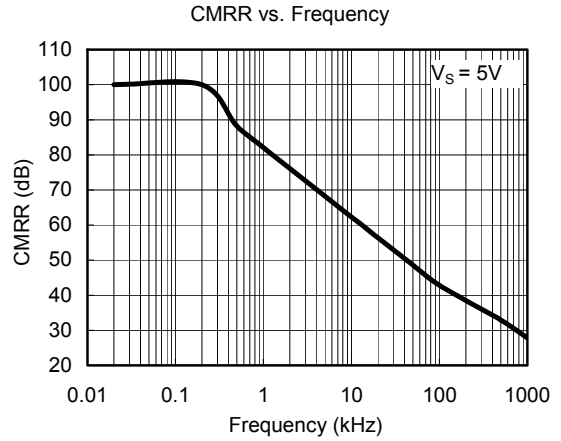
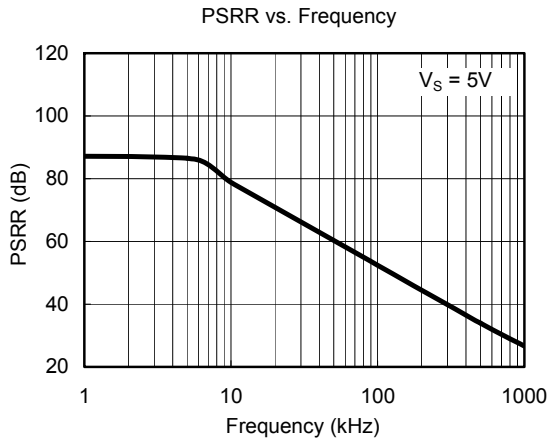

TYPICAL PERFORMANCE CHARACTERISTICS

At $T_A = +25^\circ\text{C}$, $V_{CM} = V_S/2$, $R_L = 600\Omega$, unless otherwise noted.

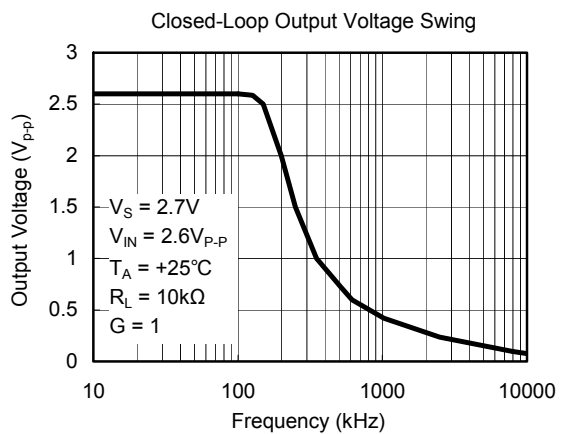
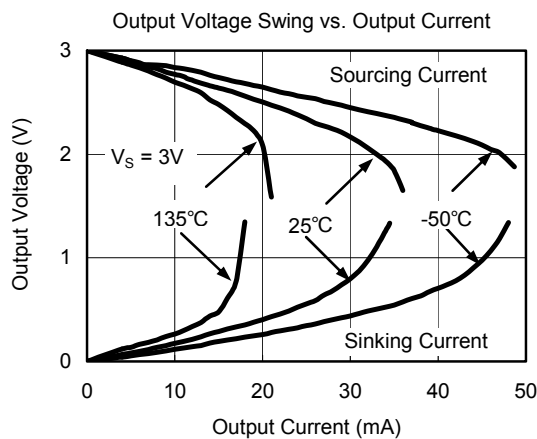
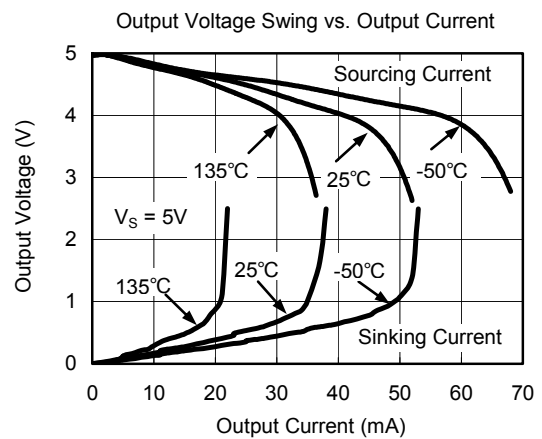
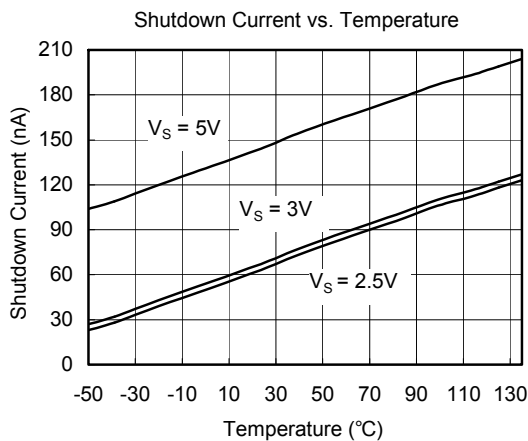
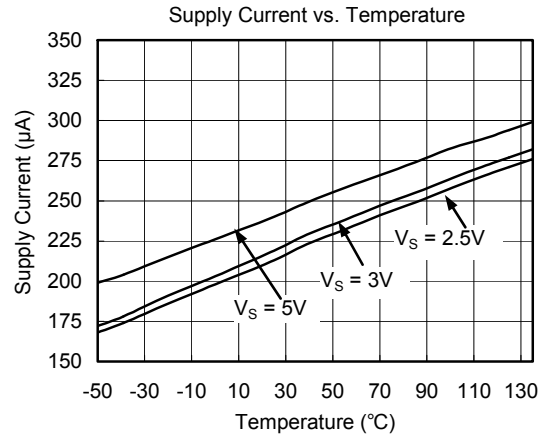
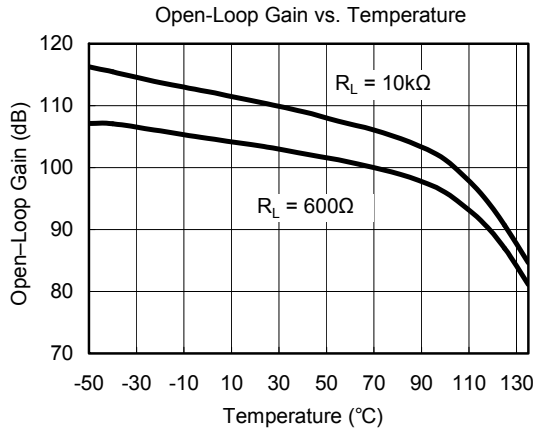

TYPICAL PERFORMANCE CHARACTERISTICS

At $T_A = +25^\circ\text{C}$, $V_{CM} = V_S/2$, $R_L = 600\Omega$, unless otherwise noted.

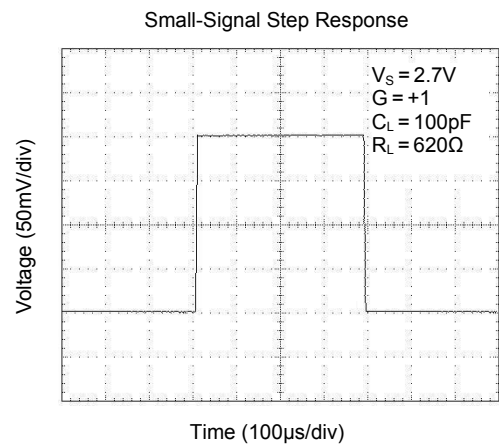
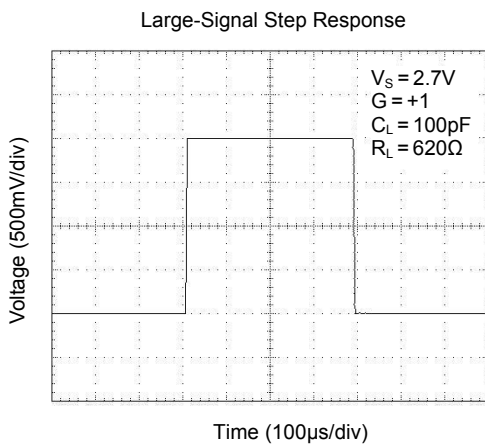
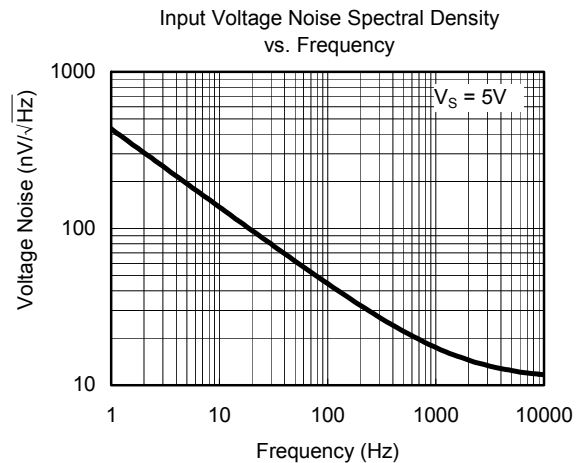
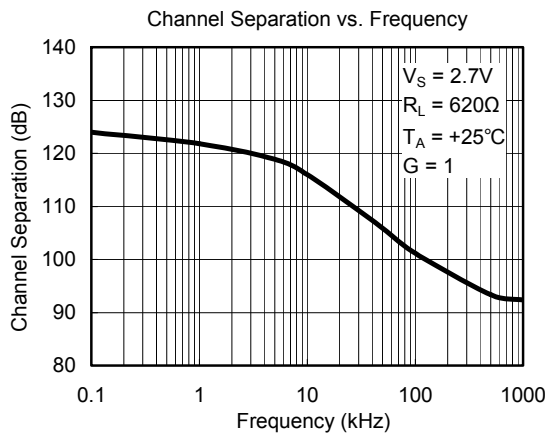
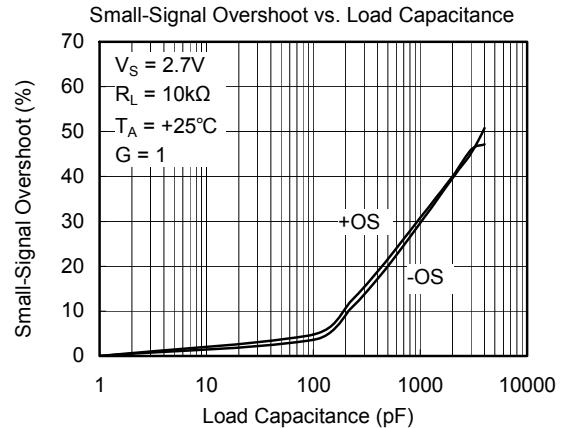
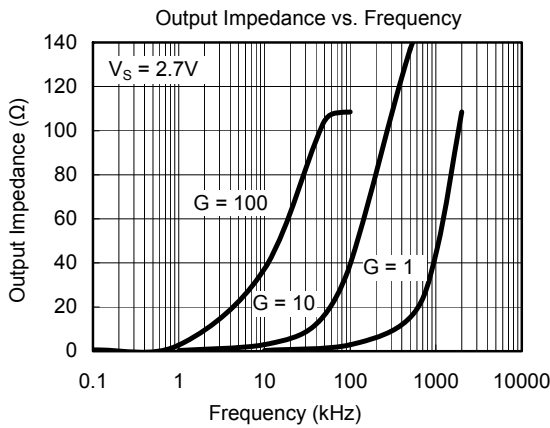

TYPICAL PERFORMANCE CHARACTERISTICS

At $T_A = +25^\circ\text{C}$, $V_{CM} = V_S/2$, $R_L = 600\Omega$, unless otherwise noted.

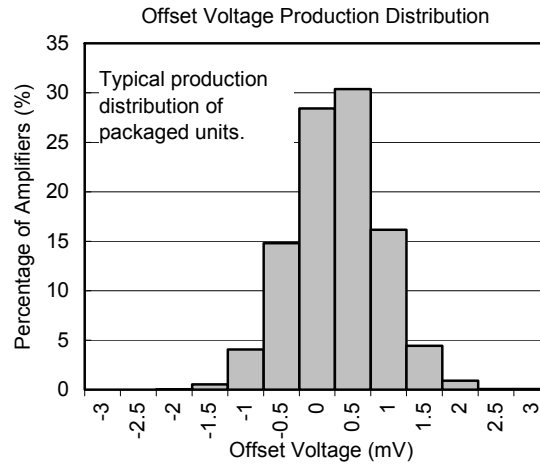

APPLICATION NOTES

Driving Capacitive Loads

The SGM8621/2/3/4 can directly drive 1000pF in unity-gain without oscillation. The unity-gain follower (buffer) is the most sensitive configuration to capacitive loading. Direct capacitive loading reduces the phase margin of amplifiers and this results in ringing or even oscillation. Applications that require greater capacitive driving capability should use an isolation resistor between the output and the capacitive load like the circuit in Figure 1. The isolation resistor R_{ISO} and the load capacitor C_L form a zero to increase stability. The bigger the R_{ISO} resistor value, the more stable V_{OUT} will be. Note that this method results in a loss of gain accuracy because R_{ISO} forms a voltage divider with the R_{LOAD} .

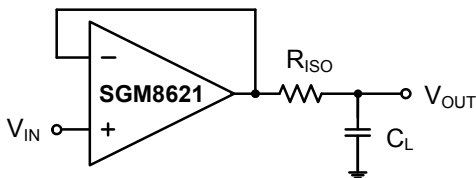

Figure 1. Indirectly Driving Heavy Capacitive Load

An improved circuit is shown in Figure 2. It provides DC accuracy as well as AC stability. R_F provides the DC accuracy by connecting the inverting signal with the output. C_F and R_{ISO} serve to counteract the loss of phase margin by feeding the high frequency component of the output signal back to the amplifier's inverting input, thereby preserving phase margin in the overall feedback loop.

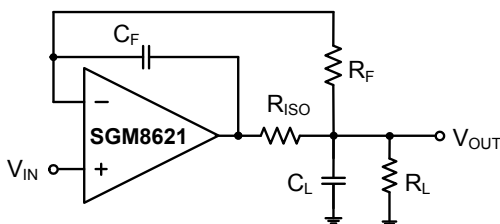

Figure 2. Indirectly Driving Heavy Capacitive Load with DC Accuracy

For non-buffer configuration, there are two other ways to increase the phase margin: (a) by increasing the amplifier's gain or (b) by placing a capacitor in parallel with the feedback resistor to counteract the parasitic capacitance associated with inverting node.

Power-Supply Bypassing and Layout

The SGM8621/2/3/4 operate from either a single +2.5V to +5.5V supply or dual $\pm 1.25V$ to $\pm 2.75V$ supplies. For single-supply operation, bypass the power supply $+V_S$ with a 0.1µF ceramic capacitor which should be placed close to the $+V_S$ pin. For dual-supply operation, both the $+V_S$ and the $-V_S$ supplies should be bypassed to ground with separate 0.1µF ceramic capacitors. 2.2µF tantalum capacitor can be added for better performance.

Good PC board layout techniques optimize performance by decreasing the amount of stray capacitance at the op amp's inputs and output. To decrease stray capacitance, minimize trace lengths and widths by placing external components as close to the device as possible. Use surface-mount components whenever possible.

For the operational amplifier, soldering the part to the board directly is strongly recommended. Try to keep the high frequency big current loop area small to minimize the EMI (electromagnetic interfacing).

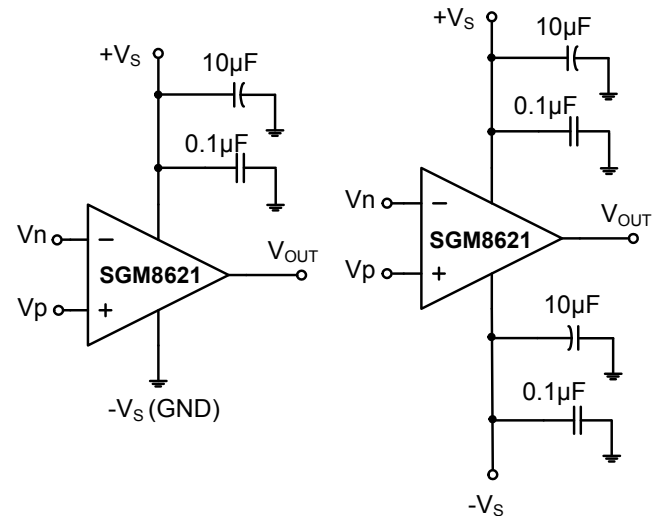

Figure 3. Amplifier with Bypass Capacitors

Grounding

A ground plane layer is important for SGM8621/2/3/4 circuit design. The length of the current path speed currents in an inductive ground return will create an unwanted voltage noise. Broad ground plane areas will reduce the parasitic inductance.

Input-to-Output Coupling

To minimize capacitive coupling, the input and output signal traces should not be parallel. This helps reduce unwanted positive feedback.

TYPICAL APPLICATION CIRCUITS

Differential Amplifier

The circuit shown in Figure 4 performs the difference function. If the resistors ratios are equal ($R_4/R_3 = R_2/R_1$), then $V_{OUT} = (V_p - V_n) \times R_2/R_1 + V_{REF}$.

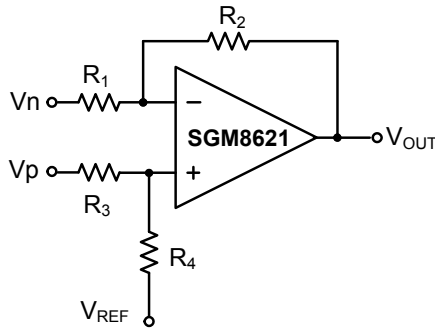

Figure 4. Differential Amplifier

Instrumentation Amplifier

The circuit in Figure 5 performs the same function as that in Figure 4 but with a high input impedance.

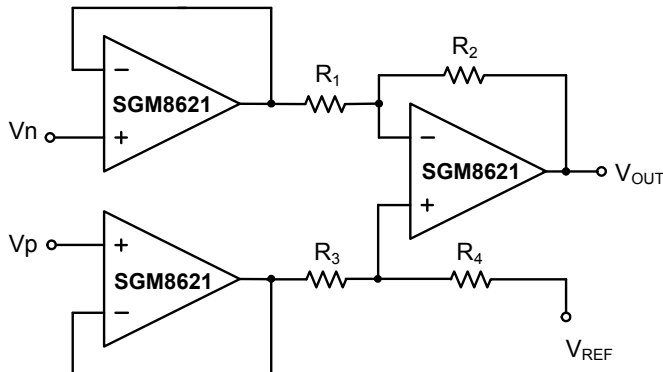

Figure 5. Instrumentation Amplifier

Low Pass Active Filter

The low pass filter shown in Figure 6 has a DC gain of $(-R_2/R_1)$ and the -3dB corner frequency is $1/2\pi R_2 C$. Make sure the filter bandwidth is within the bandwidth of the amplifier. The large values of feedback resistors can couple with parasitic capacitance and cause undesired effects such as ringing or oscillation in high-speed amplifiers. Keep resistor values as low as possible and consistent with output loading consideration.

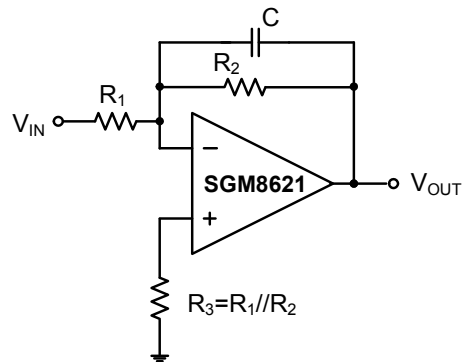
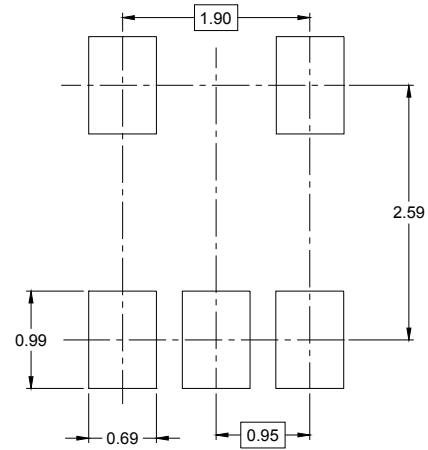
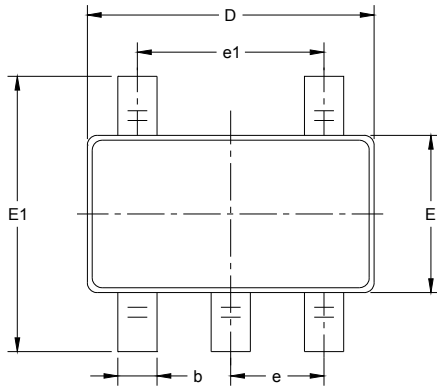

Figure 6. Low Pass Active Filter

PACKAGE OUTLINE DIMENSIONS

SOT-23-5



RECOMMENDED LAND PATTERN (Unit: mm)

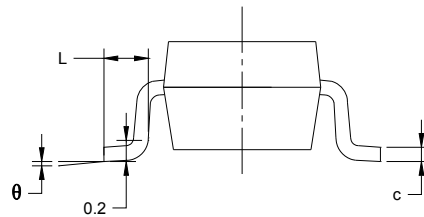
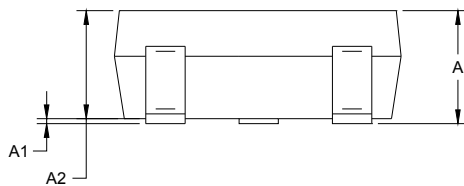

Symbol	Dimensions In Millimeters		Dimensions In Inches	
	MIN	MAX	MIN	MAX
A	1.050	1.250	0.041	0.049
A1	0.000	0.100	0.000	0.004
A2	1.050	1.150	0.041	0.045
b	0.300	0.500	0.012	0.020
c	0.100	0.200	0.004	0.008
D	2.820	3.020	0.111	0.119
E	1.500	1.700	0.059	0.067
E1	2.650	2.950	0.104	0.116
e	0.950 BSC		0.037 BSC	
e1	1.900 BSC		0.075 BSC	
L	0.300	0.600	0.012	0.024
θ	0°	8°	0°	8°

PACKAGE OUTLINE DIMENSIONS

SC70-5

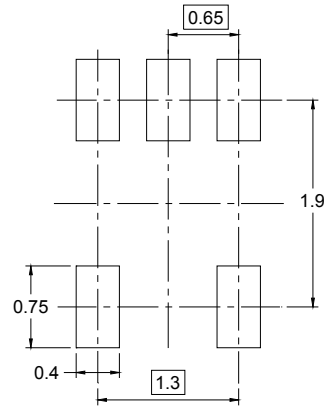
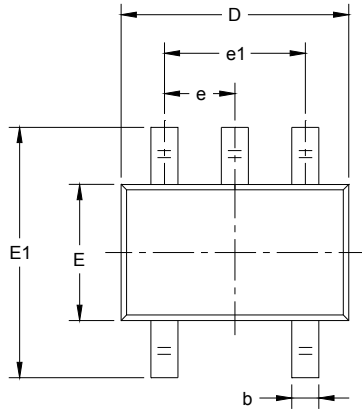

RECOMMENDED LAND PATTERN (Unit: mm)

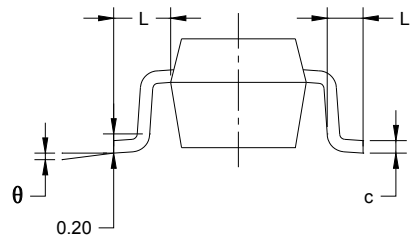
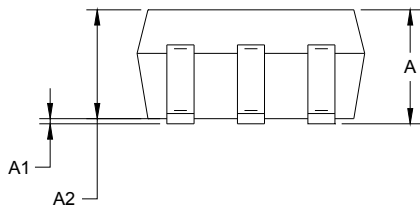

Symbol	Dimensions In Millimeters		Dimensions In Inches	
	MIN	MAX	MIN	MAX
A	0.900	1.100	0.035	0.043
A1	0.000	0.100	0.000	0.004
A2	0.900	1.000	0.035	0.039
b	0.150	0.350	0.006	0.014
c	0.080	0.150	0.003	0.006
D	2.000	2.200	0.079	0.087
E	1.150	1.350	0.045	0.053
E1	2.150	2.450	0.085	0.096
e	0.65 TYP		0.026 TYP	
e1	1.300 BSC		0.051 BSC	
L	0.525 REF		0.021 REF	
L1	0.260	0.460	0.010	0.018
θ	0°	8°	0°	8°

PACKAGE OUTLINE DIMENSIONS

SOT-23-6

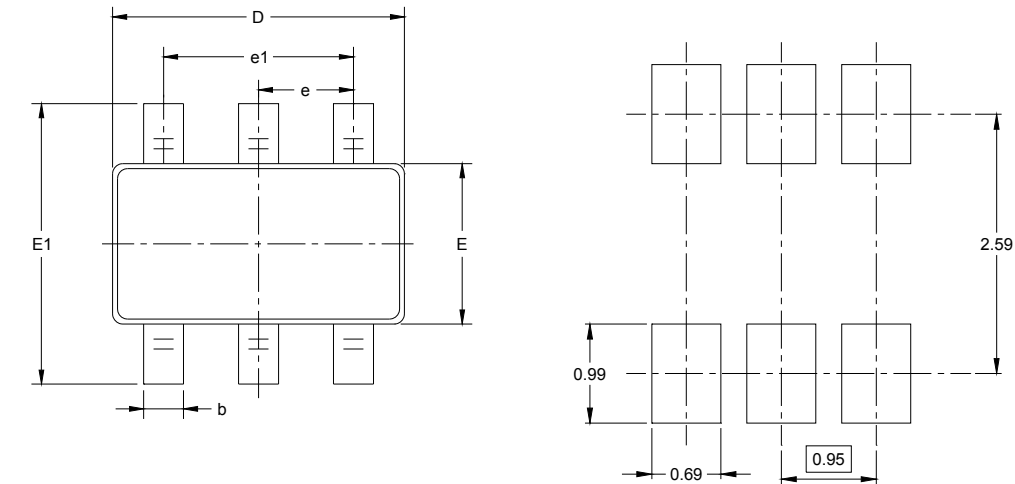

RECOMMENDED LAND PATTERN (Unit: mm)

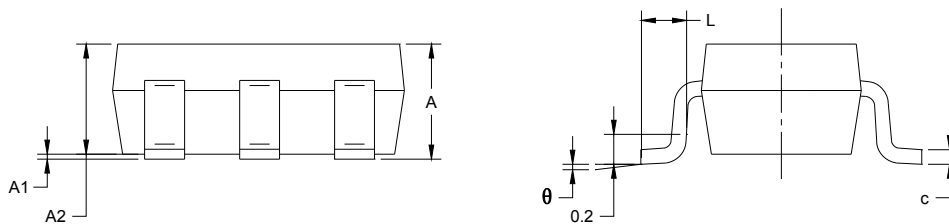

Symbol	Dimensions In Millimeters		Dimensions In Inches	
	MIN	MAX	MIN	MAX
A	1.050	1.250	0.041	0.049
A1	0.000	0.100	0.000	0.004
A2	1.050	1.150	0.041	0.045
b	0.300	0.500	0.012	0.020
c	0.100	0.200	0.004	0.008
D	2.820	3.020	0.111	0.119
E	1.500	1.700	0.059	0.067
E1	2.650	2.950	0.104	0.116
e	0.950 BSC		0.037 BSC	
e1	1.900 BSC		0.075 BSC	
L	0.300	0.600	0.012	0.024
θ	0°	8°	0°	8°

PACKAGE OUTLINE DIMENSIONS

SOIC-8

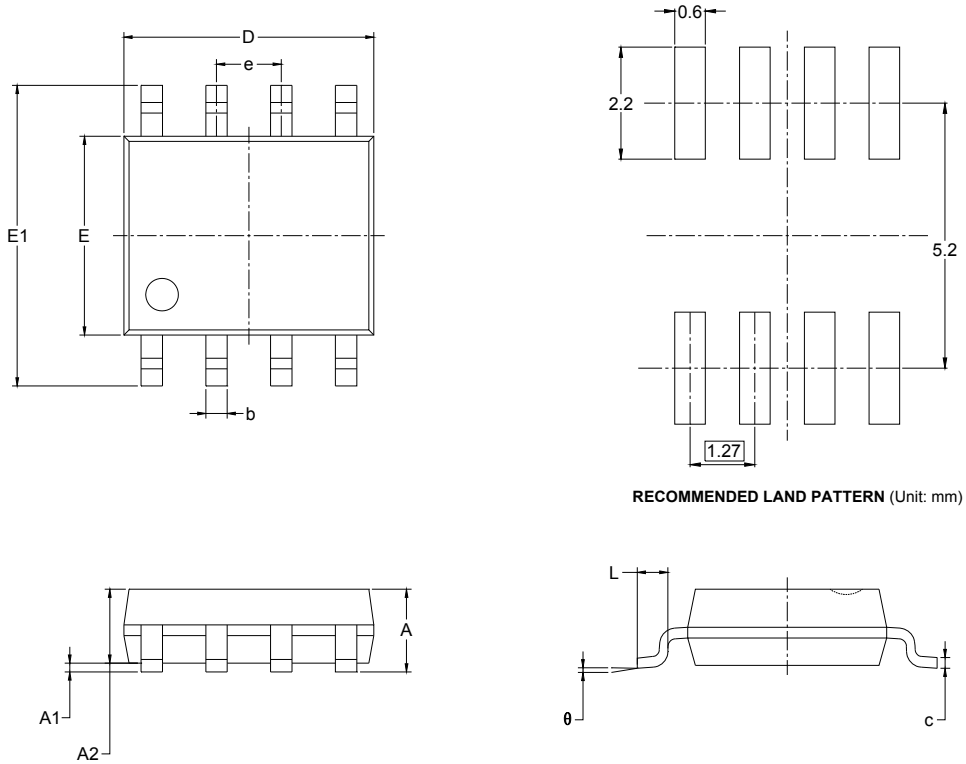

RECOMMENDED LAND PATTERN (Unit: mm)

Symbol	Dimensions In Millimeters		Dimensions In Inches	
	MIN	MAX	MIN	MAX
A	1.350	1.750	0.053	0.069
A1	0.100	0.250	0.004	0.010
A2	1.350	1.550	0.053	0.061
b	0.330	0.510	0.013	0.020
c	0.170	0.250	0.006	0.010
D	4.700	5.100	0.185	0.200
E	3.800	4.000	0.150	0.157
E1	5.800	6.200	0.228	0.244
e	1.27 BSC		0.050 BSC	
L	0.400	1.270	0.016	0.050
θ	0°	8°	0°	8°

PACKAGE OUTLINE DIMENSIONS

MSOP-8

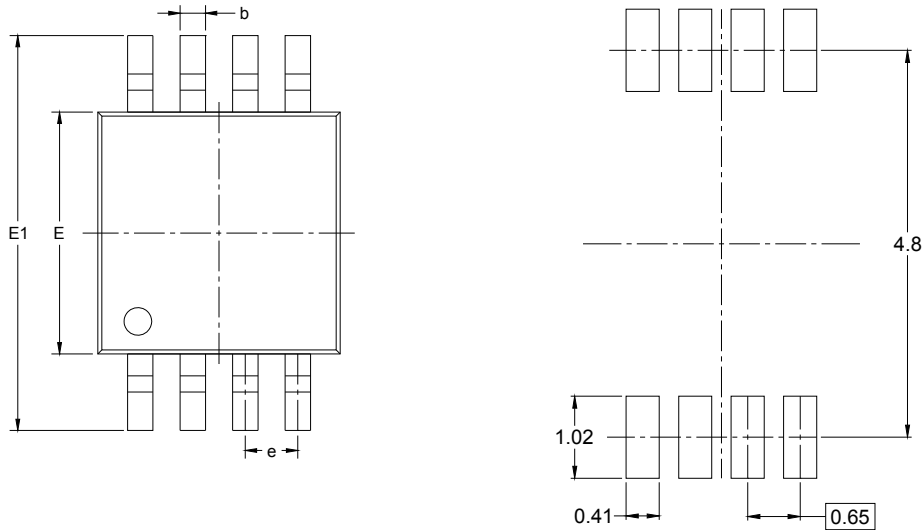

RECOMMENDED LAND PATTERN (Unit: mm)

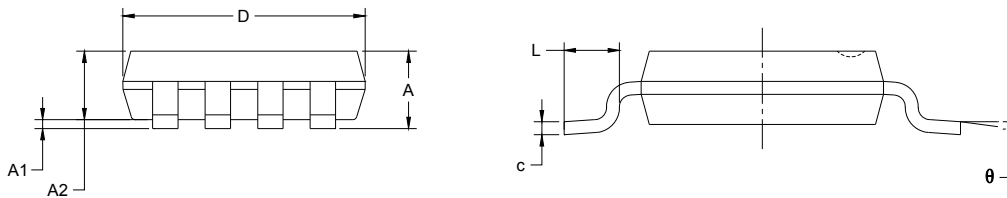

Symbol	Dimensions In Millimeters		Dimensions In Inches	
	MIN	MAX	MIN	MAX
A	0.820	1.100	0.032	0.043
A1	0.020	0.150	0.001	0.006
A2	0.750	0.950	0.030	0.037
b	0.250	0.380	0.010	0.015
c	0.090	0.230	0.004	0.009
D	2.900	3.100	0.114	0.122
E	2.900	3.100	0.114	0.122
E1	4.750	5.050	0.187	0.199
e	0.650 BSC		0.026 BSC	
L	0.400	0.800	0.016	0.031
θ	0°	6°	0°	6°

PACKAGE OUTLINE DIMENSIONS

SOIC-14

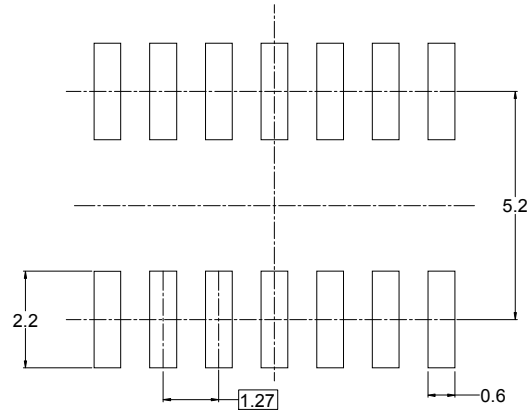
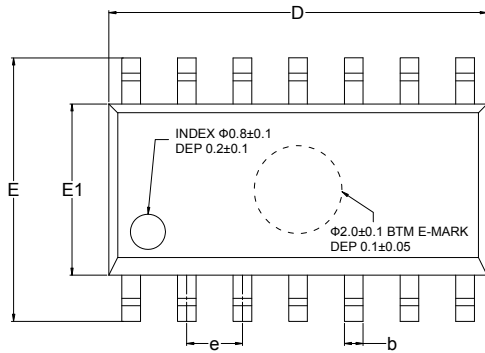

RECOMMENDED LAND PATTERN (Unit: mm)

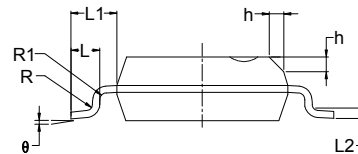
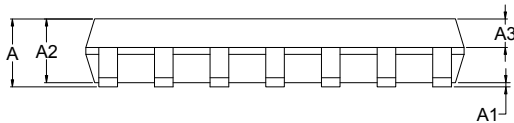

Symbol	Dimensions In Millimeters			Dimensions In Inches		
	MIN	MOD	MAX	MIN	MOD	MAX
A	1.35		1.75	0.053		0.069
A1	0.10		0.25	0.004		0.010
A2	1.25		1.65	0.049		0.065
A3	0.55		0.75	0.022		0.030
b	0.36		0.49	0.014		0.019
D	8.53		8.73	0.336		0.344
E	5.80		6.20	0.228		0.244
E1	3.80		4.00	0.150		0.157
e	1.27 BSC			0.050 BSC		
L	0.45		0.80	0.018		0.032
L1	1.04 REF			0.040 REF		
L2	0.25 BSC			0.01 BSC		
R	0.07			0.003		
R1	0.07			0.003		
h	0.30		0.50	0.012		0.020
θ	0°		8°	0°		8°

PACKAGE OUTLINE DIMENSIONS

TSSOP-14

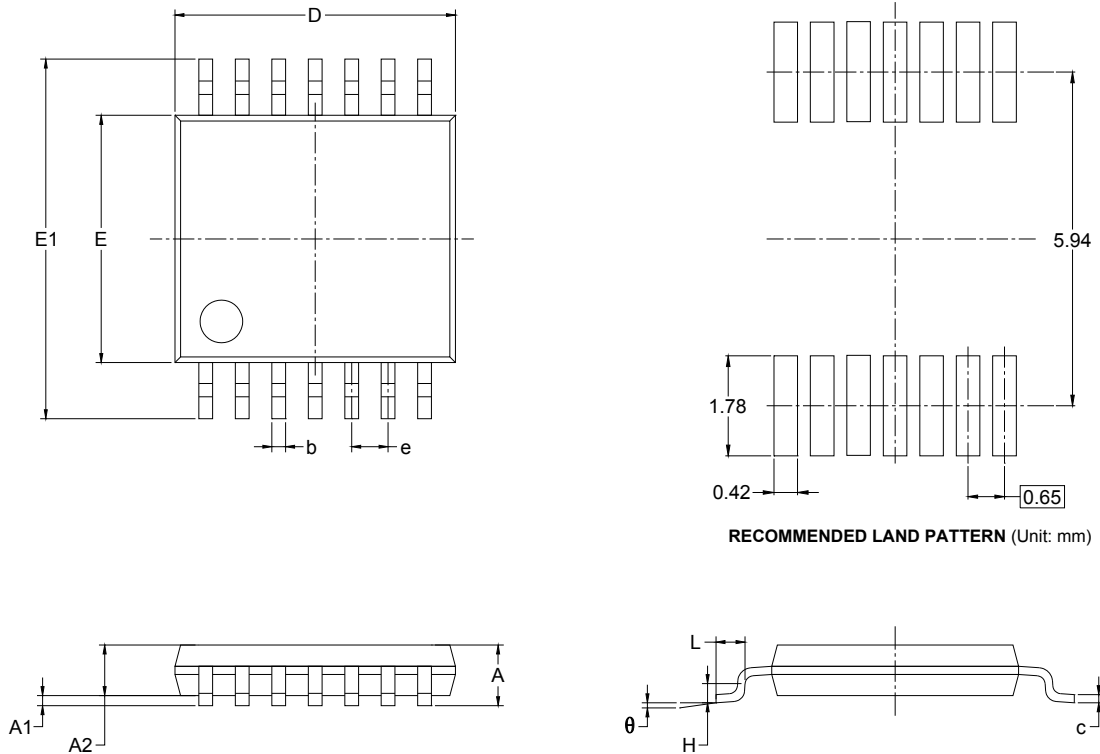

RECOMMENDED LAND PATTERN (Unit: mm)

Symbol	Dimensions In Millimeters		Dimensions In Inches	
	MIN	MAX	MIN	MAX
A		1.100		0.043
A1	0.050	0.150	0.002	0.006
A2	0.800	1.000	0.031	0.039
b	0.190	0.300	0.007	0.012
c	0.090	0.200	0.004	0.008
D	4.900	5.100	0.193	0.201
E	4.300	4.500	0.169	0.177
E1	6.250	6.550	0.246	0.258
e	0.650 BSC		0.026 BSC	
L	0.500	0.700	0.02	0.028
H	0.25 TYP		0.01 TYP	
θ	1°	7°	1°	7°

TAPE AND REEL INFORMATION

REEL DIMENSIONS

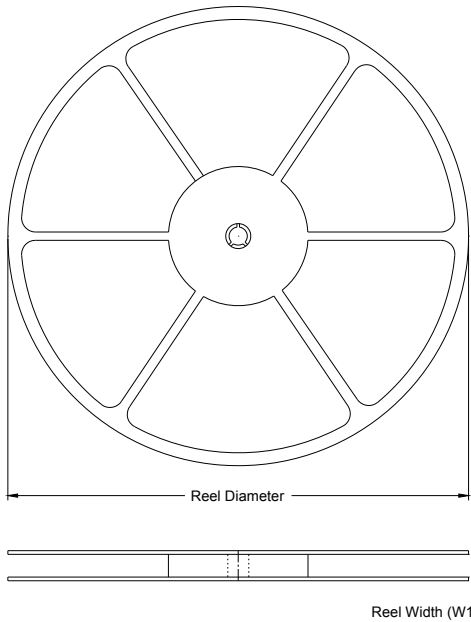

TAPE DIMENSIONS

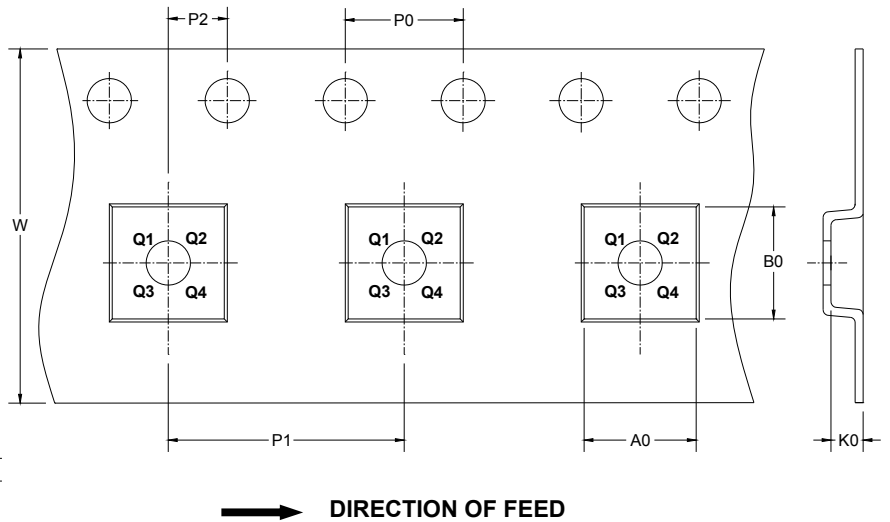

NOTE: The picture is only for reference. Please make the object as the standard.

KEY PARAMETER LIST OF TAPE AND REEL

Package Type	Reel Diameter	Reel Width W1 (mm)	A0 (mm)	B0 (mm)	K0 (mm)	P0 (mm)	P1 (mm)	P2 (mm)	W (mm)	Pin1 Quadrant
SOT-23-5	7"	9.5	3.17	3.23	1.37	4.0	4.0	2.0	8.0	Q3
SC70-5	7"	9.5	2.25	2.55	1.20	4.0	4.0	2.0	8.0	Q3
SOT-23-6	7"	9.5	3.17	3.23	1.37	4.0	4.0	2.0	8.0	Q3
SOIC-8	13"	12.4	6.4	5.4	2.1	4.0	8.0	2.0	12.0	Q1
MSOP-8	13"	12.4	5.2	3.3	1.5	4.0	8.0	2.0	12.0	Q1
SOIC-14	13"	16.4	6.6	9.3	2.1	4.0	8.0	2.0	16.0	Q1
TSSOP-14	13"	12.4	6.95	5.6	1.2	4.0	8.0	2.0	12.0	Q1

CARTON BOX DIMENSIONS

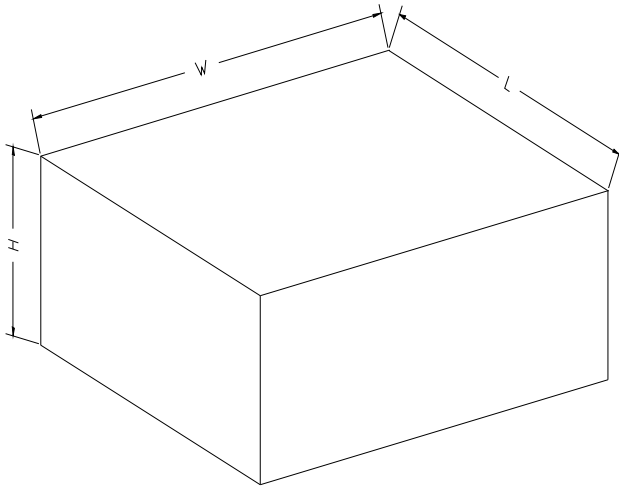

NOTE: The picture is only for reference. Please make the object as the standard.

KEY PARAMETER LIST OF CARTON BOX

Reel Type	Length (mm)	Width (mm)	Height (mm)	Pizza/Carton
7" (Option)	368	227	224	8
7"	442	410	224	18
13"	386	280	370	5