

Rev	AWO #	Description	Date	Appr
-		RELEASED	9/07/10	

APPROVED: _____
 DATE: _____ TITLE: _____

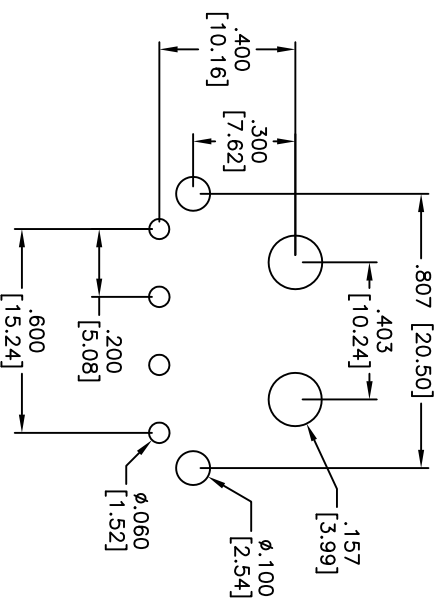
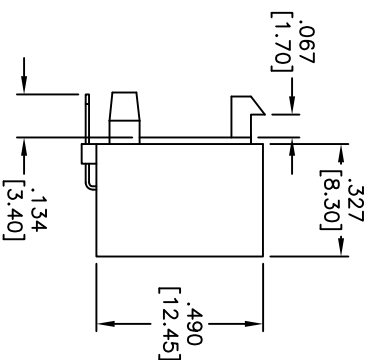
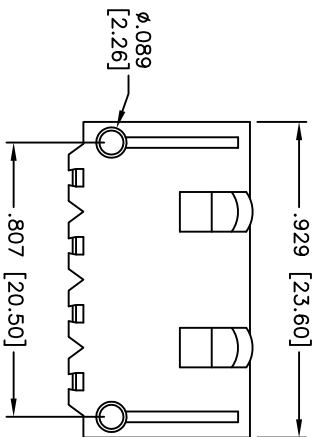
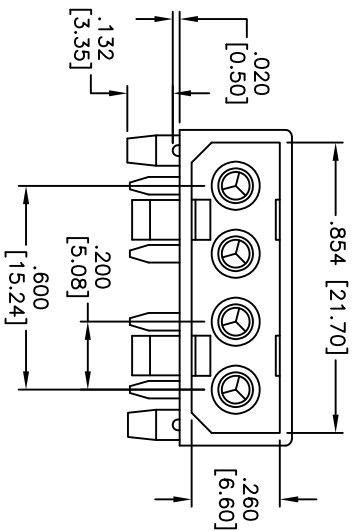

RECOMMENDED PCB LAYOUT

SPECIFICATIONS:

Material:

Insulator: Nylon 9T, rated UL 94V-2

Insulator color: Natural

Contacts: Phosphor Bronze

Plating:

Tin over nickel underplate

Electrical:

Operation voltage: 250V AC

Current rating: 6.5A

Contact resistance: 10 mohms max

Insulation resistance: 500 mohms min.

Dielectric withstanding voltage: 1500 VAC for 1 minute

Temperature rating:

Operating temperature: -40°C to +105°C

Environmental:

Lead Free, RoHS compliant

Recommended soldering temperature: 260°C for 5 seconds



UNLESS OTHERWISE SPECIFIED ALL DIMENSIONS ARE INCHES [MM]	
TOLERANCES: EXCEPT AS NOTED	
.X	±.10
.XX	±.020
.XXX	±.015
ØXX	±.015
ØXXX	±.010
APPROVALS	DATE
DRAWN	DY
CHECKED	
APPROVED	

ADAM TECH
 909 Railway Avenue, Union, NJ 07083
 Phone: 908-687-5000 Fax: 908-687-5710

TITLE
.200 [5.08] RIGHT ANGLE HEADER

SIZE	PART NO.	REV.
X	DDR-04-HT	-
REF: S0012T	SCALE: NTS	SHEET 1 OF 1