

isc Silicon NPN Power Transistor

2SC5900

DESCRIPTION

- High Breakdown Voltage-
: $V_{CBO} = 1700V$ (Min)
- High Switching Speed
- High Reliability

APPLICATIONS

- Color TV horizontal deflection output applications

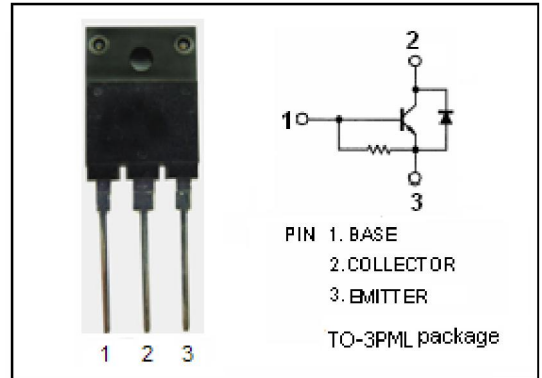

ABSOLUTE MAXIMUM RATINGS($T_a=25^{\circ}C$)

SYMBOL	PARAMETER	VALUE	UNIT
V_{CBO}	Collector-Base Voltage	1700	V
V_{CEO}	Collector-Emitter Voltage	800	V
V_{EBO}	Emitter-Base Voltage	5	V
I_C	Collector Current- Continuous	8	A
I_{CP}	Collector Current-Pulse	16	A
P_C	Collector Power Dissipation @ $T_a=25^{\circ}C$	3.0	W
	Collector Power Dissipation @ $T_c=25^{\circ}C$	80	
T_J	Junction Temperature	150	$^{\circ}C$
T_{stg}	Storage Temperature Range	-55~150	$^{\circ}C$

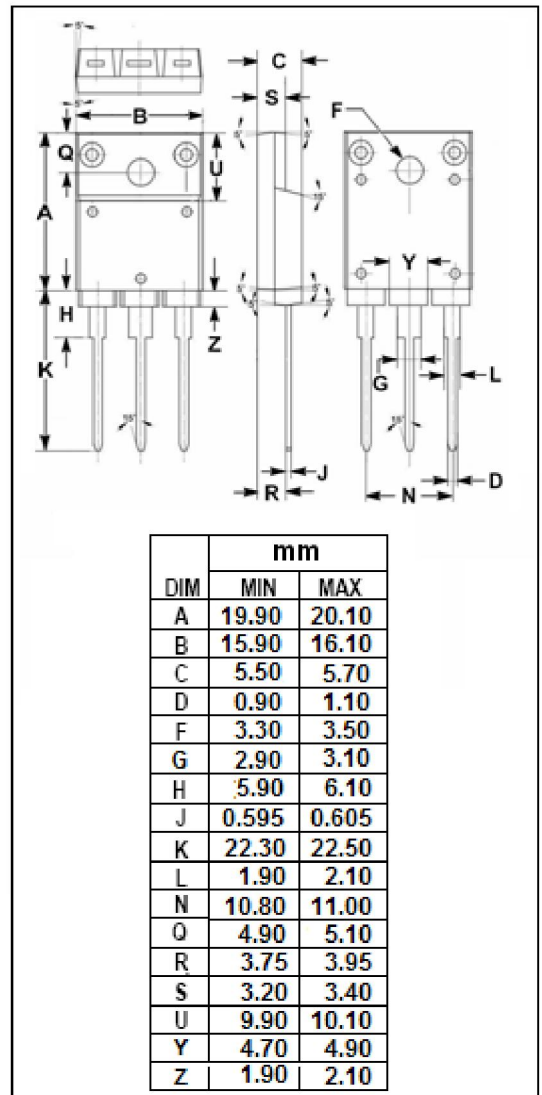

isc Silicon NPN Power Transistor**2SC5900****ELECTRICAL CHARACTERISTICS** $T_c=25^{\circ}\text{C}$ unless otherwise specified

SYMBOL	PARAMETER	CONDITIONS	MIN	TYP.	MAX	UNIT
$V_{CEQ(SUS)}$	Collector-Emitter Sustaining Voltage	$I_C=100\text{mA}; I_B=0$	800			V
$V_{CE(sat)}$	Collector-Emitter Saturation Voltage	$I_C=4\text{A}; I_B=1\text{A}$			3.0	V
$V_{BE(sat)}$	Base-Emitter Saturation Voltage	$I_C=4\text{A}; I_B=1\text{A}$			1.5	V
I_{CBO}	Collector Cutoff Current	$V_{CB}=800\text{V}; I_E=0$			10	μA
I_{CES}	Collector Cutoff Current	$V_{CE}=1700\text{V}; R_{BE}=0$			1.0	mA
I_{EBO}	Emitter Cutoff Current	$V_{EB}=4\text{V}; I_C=0$			10	mA
h_{FE-1}	DC Current Gain	$I_C=1\text{A}; V_{CE}=5\text{V}$	10			
h_{FE-2}	DC Current Gain	$I_C=4.5\text{A}; V_{CE}=5\text{V}$	4		9	
tstg	Storage Time	$I_C=3\text{A}; I_{B1}=0.5\text{A}; I_{B2}=-1.5\text{A}$			3.0	μs
tf	Fall Time	$I_C=3\text{A}; I_{B1}=0.5\text{A}; I_{B2}=-1.5\text{A}$			0.2	μs