

Features:

- ◆ Beryllia base for good thermal conduction
- ◆ Regulation temperature from 40°C to 100°C
- ◆ Electrically isolated from the case
- ◆ Epoxy sealed
- ◆ Hermetically sealed and military screened units available

**Miniature Proportionally
Controlled Heater**

Description:

The HY7110 is a miniature proportionally controlled heater whose temperature can be programmed with a single external resistor. This device is ideally suited for regulating the temperature of sensitive electronic components such as microwave filters, optical waveguides, multiplexers and crystal oscillators. The HY7110 in a ceramic package can supply up to 28 Watts of power from an unregulated 28 Volt supply.

Maximum ratings:

Rating	Symbol	Value	Unit
Supply Voltage	V _{DD}	35	Vdc
Reverse Voltage	V _R	-50	Vdc
Power Dissipation	P _D	35	Watts
Operating Temperature (Case)	T _{MAX/MIN}	100/-20	°C
Storage Temperature Range		-65 to +150	°C

OUTLINE DIMENSIONS

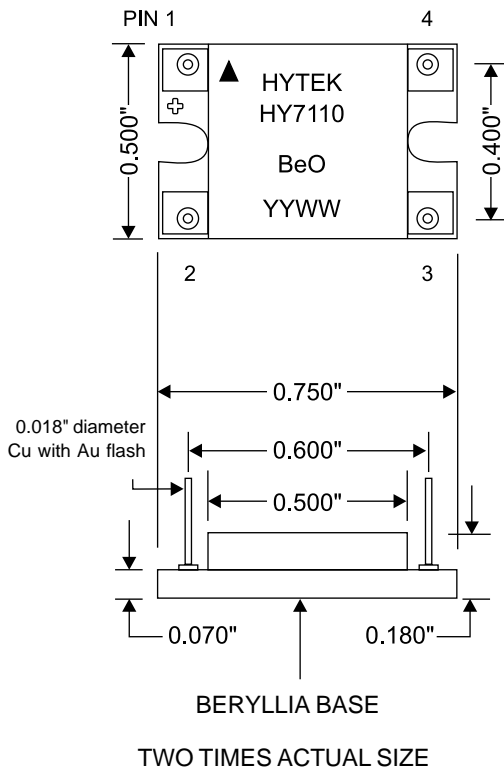

Operating characteristics:

Characteristic	Symbol	Min	Max	Unit
Supply Voltage (Pin 1 to Pin 2)	V _{DD}	+8	+35	Vdc
Steady State Supply Current @ V _{DD} = +35 Vdc	I _s	0.015	1.0	Adc
Temperature variation over operating voltage	ΔT _v		2	°C
Temperature variation with load	ΔT _L		10	°C
Control Temperature Range	T _c	50	100	°C
Control Resistor Value Pin 3 to Pin 4 (See Figure 1)	R _c	0	35K	Ω
Maximum Control Temperature when R _c = 0Ω	T _{MAX}		110	°C
Turn on power at start-up @V _{DD} = +28 Volts	P _D	25	28	Watts

TYPICAL
BASE TEMPERATURE
VS
CONTROL RESISTOR

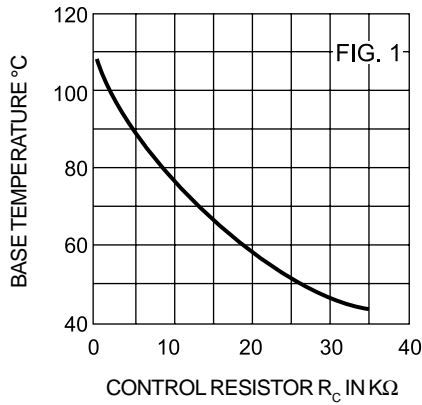

MAX START-UP CURRENT
VS
SUPPLY VOLTAGE

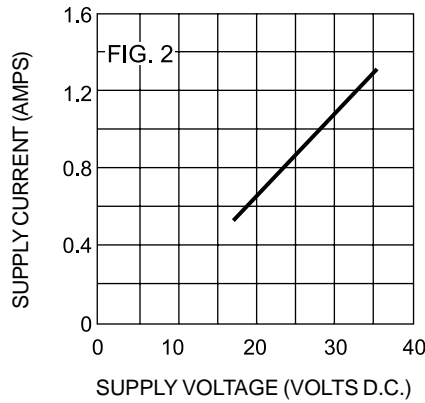

MAX THERMAL POWER
AVAILABLE
VS
SUPPLY VOLTAGE

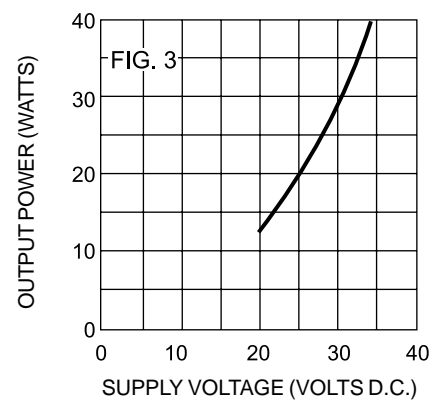

TYPICAL BASE TEMPERATURE
LOSS WITH
POWER DISSIPATION

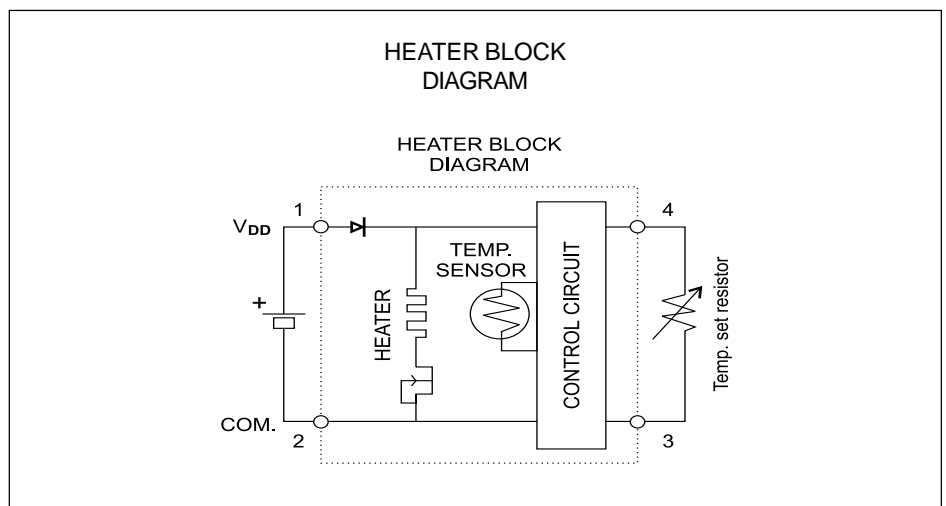
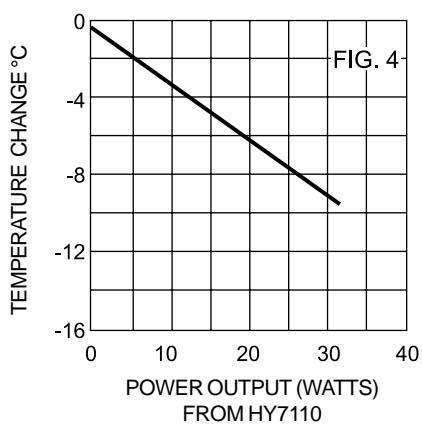

MOUNTING THE HY7110 HEATER

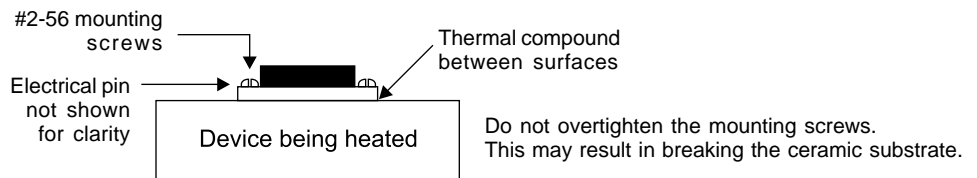

NOTES:

1. Optimum heat transfer between the HY7110 and the device being heated occurs when a thermal compound, such as Dow Corning 340, is applied to the mounting surface of the heater.
2. Operation is possible from 100 °C to 120°C, however electrical performance is not guaranteed.
3. Special environmental and electrical screening is available on request.
4. Special custom engineered micro-heater available on request.