

LD67D7S-A/B/C

InGaAlP Laser Diode

Quantum Semiconductor International Co., Ltd.

2004. Rev 1.

◆ OVERVIEW

LD67D7S-A/B/C is a MOCVD grown 670nm band **Index-Guided** type *InGaAlP* laser diode with quantum well structure. It's an attractive light source, with a typical light output power of 5mW for optoelectronic devices such as Bar Code Reader.

◆ APPLICATION

- Optical Leveler
- Laser Module
- Bar Code Reader

◆ FEATURES

- Visible Light Output : $\lambda_p = 670 \text{ nm}$
- Optical Power Output : 5mW CW
- Package Type : TO-18 (5.6mm ϕ)
- Built-in Photo Diode for Monitoring Laser Diode

◆ ELECTRICAL CONNECTION

Bottom View

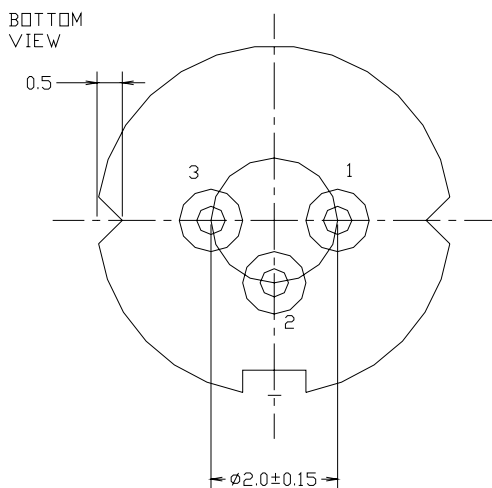

Pin Configuration

A	LD cathode, PD anode (Fig. 1)
B	LD , PD anode (Fig. 2)
C	LD anode, PD cathode (Fig. 3)

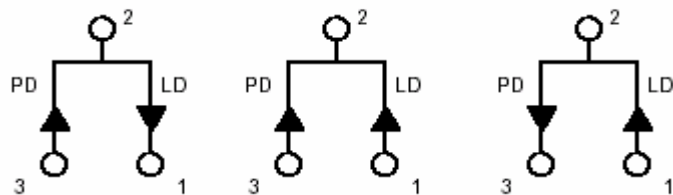

Fig. 1

LD67D7SA

Fig. 2

LD67D7SB

Fig. 3

LD67D7SC

◆ ABSOLUTE MAXIMUM RATING at Tc=25°C

Items	Symbols	Values	Unit
Optical Output Power	P	7	mW
Laser Diode Reverse Voltage	V	2	V
Photo Diode Reverse Voltage	V	30	V
Operating Temperature	Topr	-10 ~ +70	°C
Storage Temperature	Tstg	-40 ~ +85	°C

◆ ELECTRICAL and OPTICAL CHARACTERISTICS at Tc=25°C

Items	Symbols	Min.	Typ.	Max.	Unit	Condition
Optical Output Power	Po	-	5	-	mW	-
Threshold Current	Ith	-	20	40	mA	-
Operating Current	Iop	-	30	45	mA	Po=5mW
Operating Voltage	Vop	-	2.3	2.6	V	Po=5mW
Lasing Wavelength	λ_p	660	670	680	nm	Po=5mW
Beam Divergence	$\theta_{ }$	7	9	11	deg	Po=5mW
	θ_{\perp}	20	28	35	deg	Po=5mW
Beam Angle	$\Delta\theta_{ }$	-	-	±1.5	deg	Po=5mW
	$\Delta\theta_{\perp}$	-	-	±2.5	deg	Po=5mW
Monitor Current	I _m	0.1	0.2	0.5	mA	Po=5mW
Astigmatism	As		8		μm	
Optical Distance	$\Delta X, \Delta Y, \Delta Z$	-	-	±60	μm	-

NOTICE : LD67D7S-A/B/C to be operated on APC

The above product specifications are subject to change without notice.

◆ PACKAGE DIMENSION

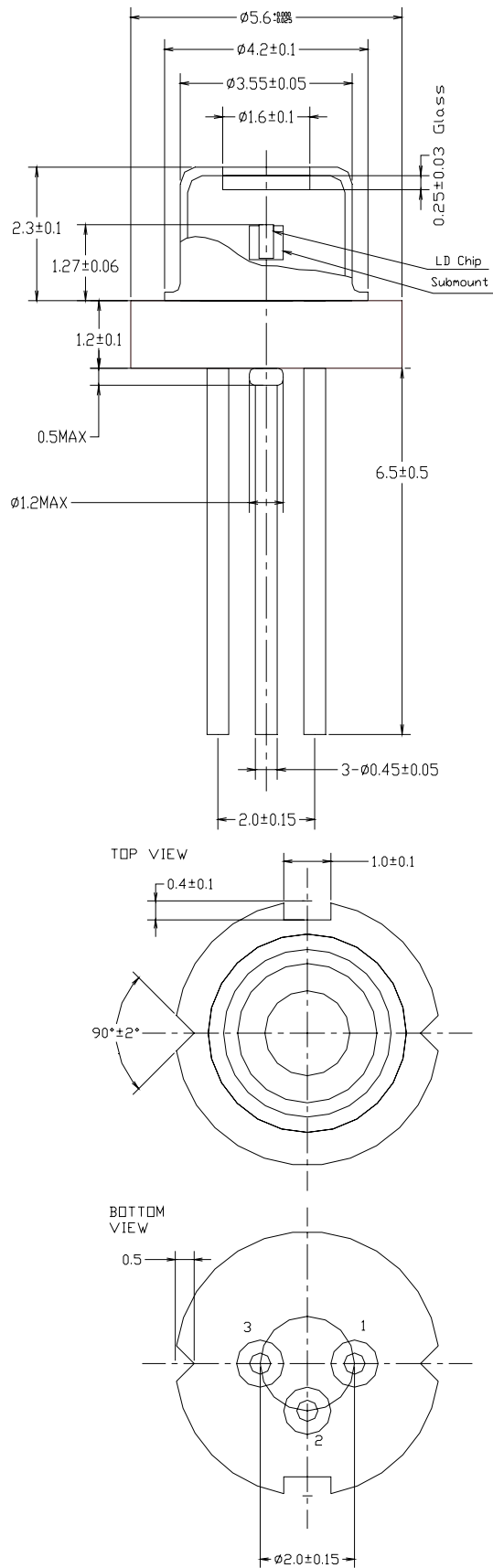

◆ PACKING

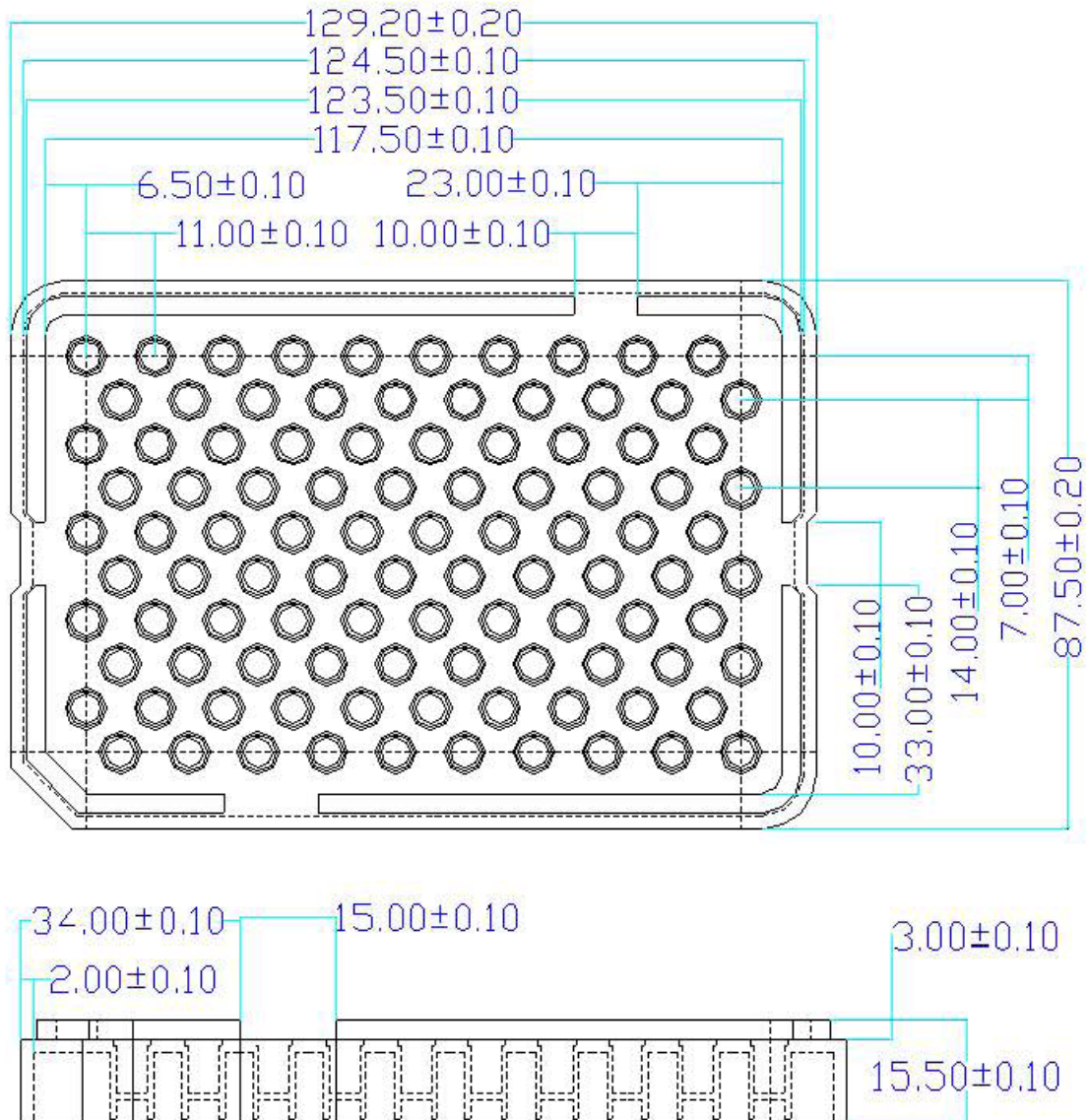

International Sales

First Sensor AG
 Peter-Behrens-Str. 15
 12459 Berlin
 Germany
 T +49 30 6399 2399
 F +49 30 6399 23-752
 sales.opto@first-sensor.com
 www.first-sensor.com

US Sales

First Sensor Inc.
 5700 Corsa Avenue #105
 Westlake Village, CA 91362
 USA
 T +1 818 7063 400
 F +1 818 8897 053
 sales.us@first-sensor.com
 www.first-sensor.com

