

FEATURES

- Plastic package has Underwriters Laboratory Flammability Classification 94V-0
- Metal silicon junction ,majority carrier conduction
- Guard ring for overvoltage protection
- Low power loss ,high efficiency
- High current capability ,Low forward voltage drop
- High surge capability
- For use in low voltage ,high frequency inverters, free wheeling ,and polarity protection applications
- High temperature soldering guaranteed:250 C/10 seconds at terminals, 0.375"(9.5mm)lead length,5lbs.(2.3kg)tension

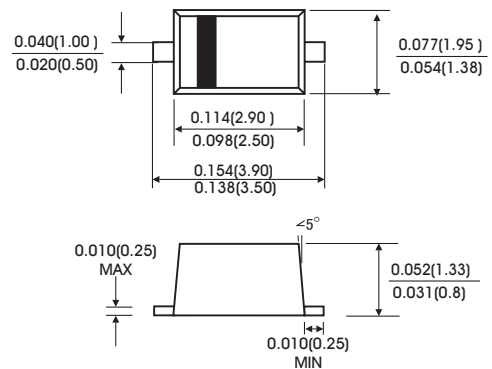

SOD-123FL



Dimensions in inches and (millimeters)

MECHANICAL DATA

- Case: SOD-123FL molded plastic body
- Lead Finish: 100% Matte Sn (Tin)
- Polarity: color band denotes cathode end
- Mounting Position: Any
- Weight: 11.7 mg(approximately)

MAXIMUM RATINGS AND ELECTRICAL CHARACTERISTICS

(Ratings at 25 °C ambient temperature unless otherwise specified ,Single phase ,half wave ,resistive or inductive load. For capacitive load,derate by 20%.)

	Symbols	SR 120SF	SR 130SF	SR 140SF	SR 150SF	SR 160SF	SR 180SF	SR 1100SF	Units
Maximum repetitive peak reverse voltage	V _{RRM}	20	30	40	50	60	80	100	Volts
Maximum RMS voltage	V _{RMS}	14	21	28	35	42	57	71	Volts
Maximum DC blocking voltage	V _{DC}	20	30	40	50	60	80	100	Volts
Maximum average forward rectified current	I _(AV)	1.0							Amp
Peak forward surge current 8.3ms single half sine-wave superimposed on rated load (JEDEC method)	I _{FSM}	40.0							Amps
Maximum instantaneous forward voltage at 1.0 A(Note 1)	V _F	0.55		0.70		0.85		Volts	
Maximum instantaneous reverse current at rated DC blocking voltage(Note 1)	T _a = 25°C	0.2							mA
	T _a = 100°C	10							
Typical junction capacitance(Note 3)	C _J	110							pF
Typical thermal capacitance(Note 2)	R _{θJA}	82.0							°C/W
	R _{θJL}	26.0							
Operating junction temperature range	T _J	-65 to +150							°C
Storage temperature range	T _{STG}	-65 to +150							°C

Notes: 1.Pulse test: 300 μs pulse width,1% duty cycle

2.Thermal resistance (from junction to ambient)Vertical P.C.B. mounted with 1 in. copper pad (Cu area 700 mm²).

3.Measured at 1.0MHz and reverse voltage of 4.0 volts

RATINGS AND CHARACTERISTIC CURVES SR120SF THRU SR1100SF

FIG.1-FORWARD CURRENT DERATING CURVE

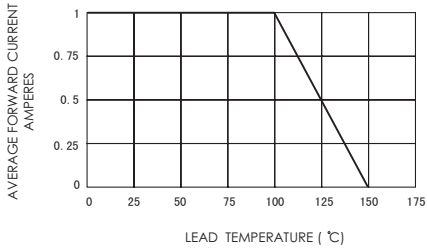

FIG.2-MAXIMUM NON-REPETITIVE PEAK FORWARD SURGE CURRENT

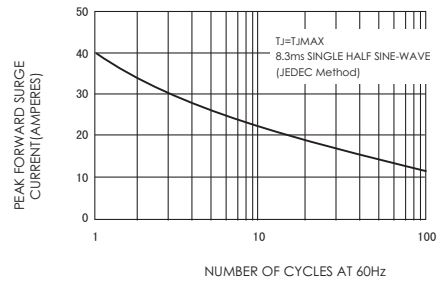

FIG.3-TYPICAL INSTANTANEOUS FORWARD CHARACTERISTICS

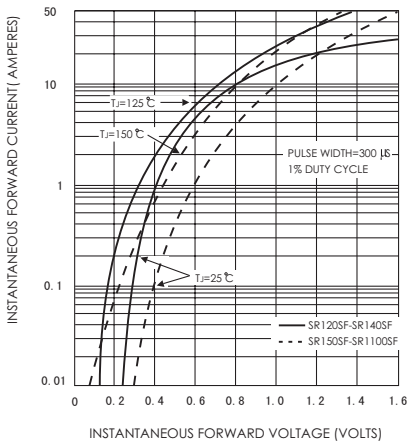

FIG.4-TYPICAL REVERSE CHARACTERISTICS

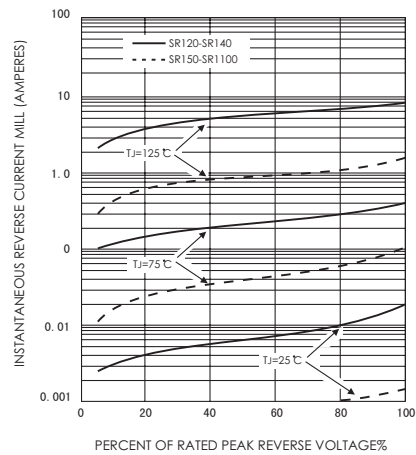

FIG.5-TYPICAL JUNCTION CAPACITANCE

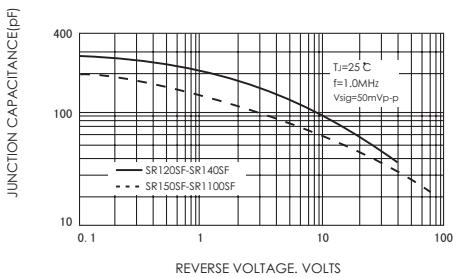

FIG.6-TYPICAL TRANSIENT THERMAL IMPEDANCE

