

**Low Dropout CMOS Voltage Regulators**

# LM1114B

**Features**

- Maximum output current 250mA
- Highly accurate : output voltage $\pm 2\%$
- Low power consumption : typ.  $2 \mu A$
- Small input/output differential:  
 0.45V typ at 160mA( 2.5V, 3.0V, 3.3V, 3.6V)  
 0.35V typ at 200mA( $V_{out}=5V$ )
- Pb-free lead plating and halogen-free package

**Applications**

- Battery powered equipment
- Palmtops
- Portable cameras and video recorders
- Reference voltage sources

**Product Description**

The LM1114B series is a group of positive voltage output, three-pin regulators, that provide a high current even when the input/output voltage differential is small. Low power consumption and high accuracy is achieved through CMOS and programmable fuse technologies.

The LM1114B consists of a high-precision voltage reference, an error correction circuit, and a current limited output driver. Transient response to load variations is improved in comparison to the existing ones.

**Absolute Maximum Ratings**

Parameter	Symbol	Ratings	Units
Input Voltage	$V_{in}$	12	V
Output Current	$I_{out}$	500	mA
Output Voltage	$V_{out}$	$V_{ss}-0.3 \sim V_{in}+0.3$	V
Continuous Total Power Dissipation	TO-92 SOT-23 SOT-89	500	mW
		150	
		500	
Operating Ambient Temperature	$T_{opr}$	-40~+85	$^{\circ}C$
Storage Temperature	$T_{stg}$	-40~+125	$^{\circ}C$

**Pin Configuration**

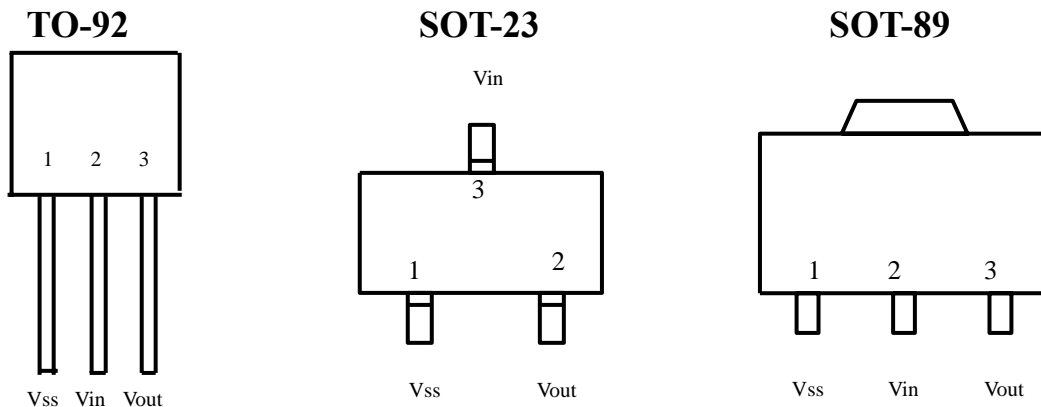

**Block Diagram**

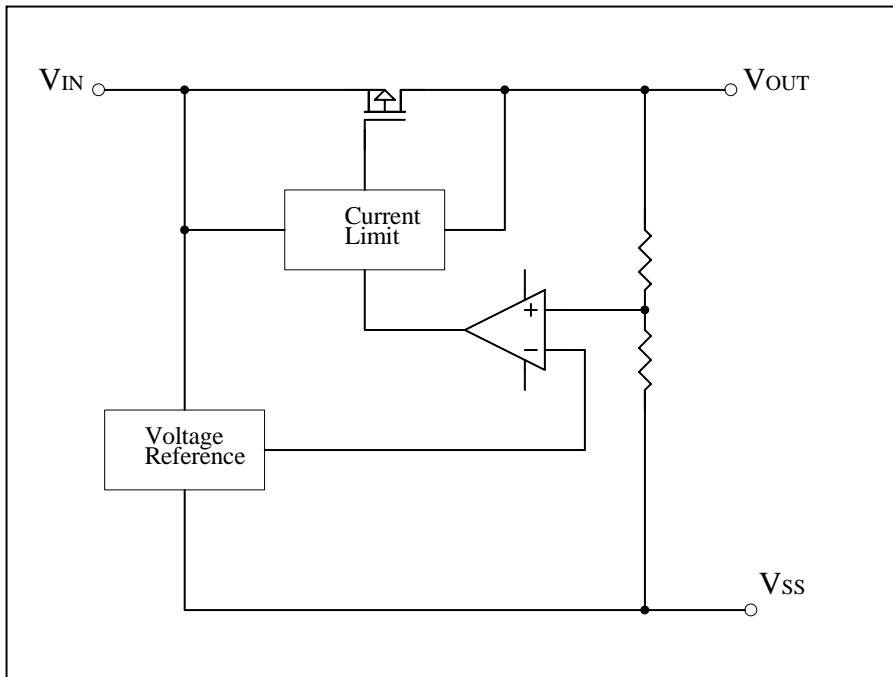

**Typical Application Circuit**

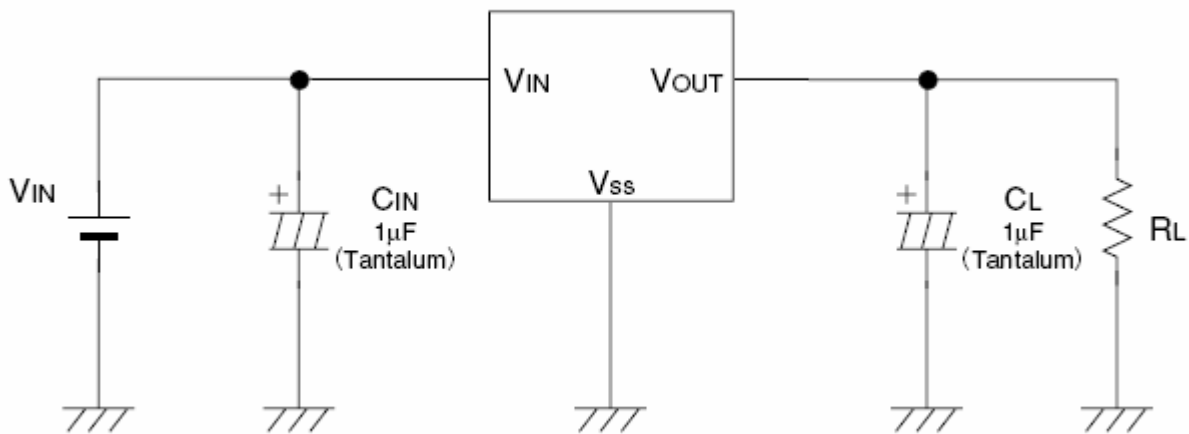



**Ordering Information**

Device	Output Voltage	Package	Shipping
LM1114-1.8 BA3 -0-TB -G	1.8V	TO-92 (Pb-free lead plating and halogen-free package)	Tape & Box / 2K
LM1114-1.8 BN3 -0-T1 -G	1.8V	SOT-23 (Pb-free lead plating and halogen-free package)	Tape & Reel / 3K
LM1114-1.8 BM3 -0-T2 -G	1.8V	SOT-89 (Pb-free lead plating and halogen-free package)	Tape & Reel / 1K
LM1114-2.5 BA3 -0-TB -G	2.5V	TO-92 (Pb-free lead plating and halogen-free package)	Tape & Box / 2K
LM1114-2.5 BN3 -0-T1 -G	2.5V	SOT-23 (Pb-free lead plating and halogen-free package)	Tape & Reel / 3K
LM1114-2.5 BM3 -0-T2 -G	2.5V	SOT-89 (Pb-free lead plating and halogen-free package)	Tape & Reel / 1K
LM1114-3.0 BA3 -0-TB -G	3.0V	TO-92 (Pb-free lead plating and halogen-free package)	Tape & Box / 2K
LM1114-3.0 BN3 -0-T1 -G	3.0V	SOT-23 (Pb-free lead plating and halogen-free package)	Tape & Reel / 3K
LM1114-3.0 BM3 -0-T2 -G	3.0V	SOT-89 (Pb-free lead plating and halogen-free package)	Tape & Reel / 1K
LM1114-3.3 BA3 -0-TB -G	3.3V	TO-92 (Pb-free lead plating and halogen-free package)	Tape & Box / 2K
LM1114-3.3 BN3 -0-T1 -G	3.3V	SOT-23 (Pb-free lead plating and halogen-free package)	Tape & Reel / 3K
LM1114-3.3 BM3 -0-T2 -G	3.3V	SOT-89 (Pb-free lead plating and halogen-free package)	Tape & Reel / 1K
LM1114-3.6 BA3 -0-TB -G	3.6V	TO-92 (Pb-free lead plating and halogen-free package)	Tape & Box / 2K
LM1114-3.6 BN3 -0-T1 -G	3.6V	SOT-23 (Pb-free lead plating and halogen-free package)	Tape & Reel / 3K
LM1114-3.6 BM3 -0-T2 -G	3.6V	SOT-89 (Pb-free lead plating and halogen-free package)	Tape & Reel / 1K
LM1114-5.0 BA3 -0-TB -G	5.0V	TO-92 (Pb-free lead plating and halogen-free package)	Tape & Box / 2K
LM1114-5.0 BN3 -0-T1 -G	5.0V	SOT-23 (Pb-free lead plating and halogen-free package)	Tape & Reel / 3K
LM1114-5.0 BM3 -0-T2 -G	5.0V	SOT-89 (Pb-free lead plating and halogen-free package)	Tape & Reel / 1K

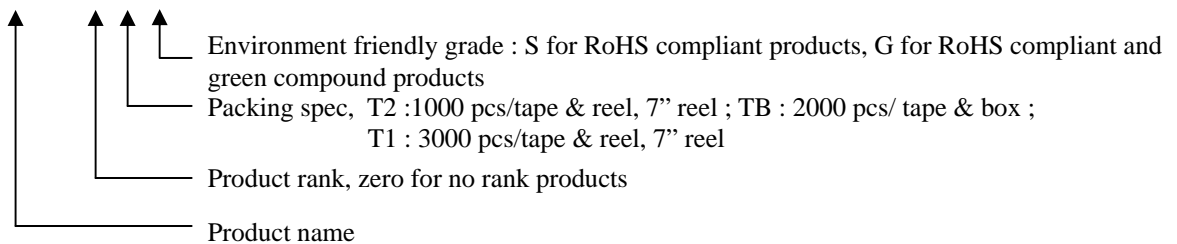

**Electrical Characteristics @VIN=5V, Ta=25°C, CIN=1μF(tantalum),  
COUT=1μF(tantalum), unless otherwise noted****LM1114-1.8**

Parameter	Conditions	Min	Typ	Max	Units	Circuit
Output Voltage	Io=40mA, Vin=2.8V	1.764	1.800	1.836	V	1
Line Regulation $\Delta V_{out}/\Delta V_{in}$	Io=40mA, 4V<Vin<10V	-	0.2	0.3	%/V	1
Load Regulation	Vin=2.8V, 1mA<Io<40mA	-	10	30	mV	1
Supply Current	Vin=2.8V	-	2.0	4.5	μA	2
Dropout Voltage	Io=40mA	-	0.2	0.36	V	1
	Io=80mA	-	0.45	0.7	V	1

**LM1114-2.5**

Parameter	Conditions	Min	Typ	Max	Units	Circuit
Output Voltage	Io=40mA, Vin=4V	2.450	2.500	2.550	V	1
Line Regulation $\Delta V_{out}/\Delta V_{in}$	Io=40mA, 4V<Vin<10V	-	0.2	0.3	%/V	1
Load Regulation	Vin=4V, 1mA<Io<80mA	-	15	40	mV	1
Supply Current	Vin=4V	-	2.0	4.5	μA	2
Dropout Voltage	Io=80mA	-	0.2	0.36	V	1
	Io=160mA	-	0.45	0.7	V	1

**LM1114-3.0**

Parameter	Conditions	Min	Typ	Max	Units	Circuit
Output Voltage	Io=40mA, Vin=4.0V	2.940	3.000	3.060	V	1
Line Regulation $\Delta V_{out}/\Delta V_{in}$	Io=40mA, 4.0V<Vin<10V	-	0.2	0.3	%/V	1
Load Regulation	Vin=6V, 1mA<Io<80mA	-	15	40	mV	1
Supply Current	Vin=4.0V	-	2.0	4.5	μA	2
Dropout Voltage	Io=80mA	-	0.24	0.36	V	1
	Io=160mA	-	0.45	0.7	V	1

**LM1114-3.3**

Parameter	Conditions	Min	Typ	Max	Units	Circuit
Output Voltage	Io=40mA, Vin=4.3V	3.234	3.300	3.366	V	1
Line Regulation $\Delta V_{out}/\Delta V_{in}$	Io=40mA, 4.3V<Vin<10V	-	0.2	0.3	%/V	1
Load Regulation	Vin=6V, 1mA<Io<80mA	-	15	40	mV	1
Supply Current	Vin=4.3V	-	2.0	4.5	μA	2
Dropout Voltage	Io=80mA	-	0.22	0.36	V	1
	Io=160mA	-	0.45	0.7	V	1

**LM1114-3.6**

Parameter	Conditions	Min	Typ	Max	Units	Circuit
Output Voltage	Io=40mA, Vin=4.6V	3.522	3.600	3.672	V	1
Line Regulation $\Delta V_{out}/\Delta V_{in}$	Io=40mA, 4.6V<Vin<10V	-	0.2	0.3	%/V	1

Load Regulation	$V_{in}=6V, 1mA < I_o < 80mA$	-	15	40	mV	1
Supply Current	$V_{in}=4.6V$	-	2.0	4.5	$\mu A$	2
Dropout Voltage	$I_o=80mA$	-	0.22	0.36	V	1
	$I_o=160mA$	-	0.45	0.7	V	1

**LM1114-5.0**

Parameter	Conditions	Min	Typ	Max	Units	Circuit
Output Voltage	$I_o=40mA, V_{in}=6.0V$	4.900	5.000	5.100	V	1
Line Regulation $\Delta V_{out}/\Delta V_{in} V_{out}$	$I_o=40mA, 6.0V < V_{in} < 10V$	-	0.2	0.3	%/V	1
Load Regulation	$V_{in}=6V, 1mA < I_o < 100mA$	-	30	70	mV	1
Supply Current	$V_{in}=6.0V$	-	2.0	4.5	$\mu A$	2
Dropout Voltage	$I_o=100mA$	-	0.21	0.3	V	1
	$I_o=200mA$	-	0.35	0.6	V	1

**Test Circuits**

**Circuit 1**

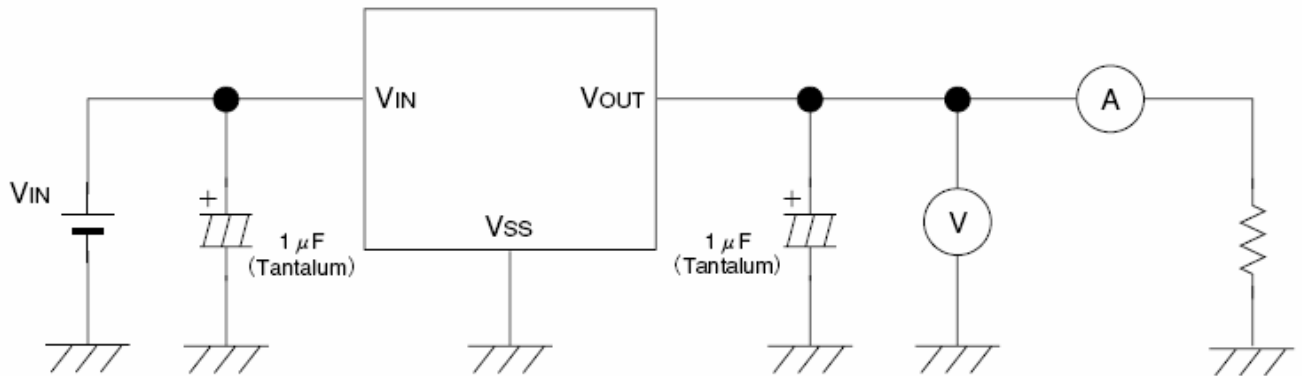

**Circuit 2**

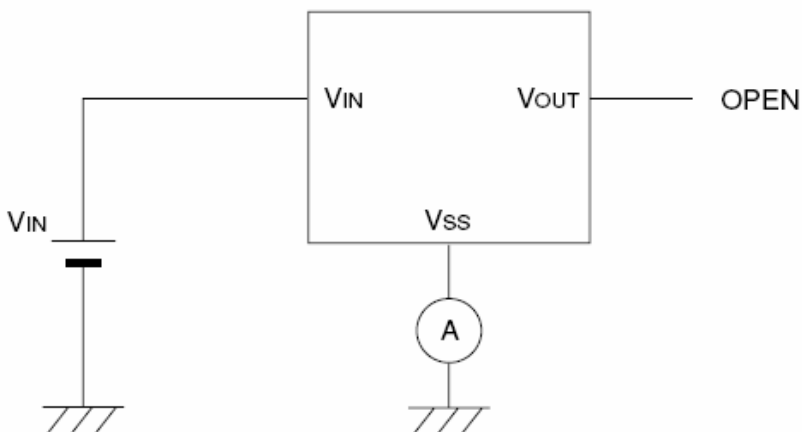



Characteristic Curves @C<sub>IN</sub>=1μF(tantalum), C<sub>OUT</sub>=1μF(tantalum)

LM1114-3.0

Output Voltage vs Input Voltage

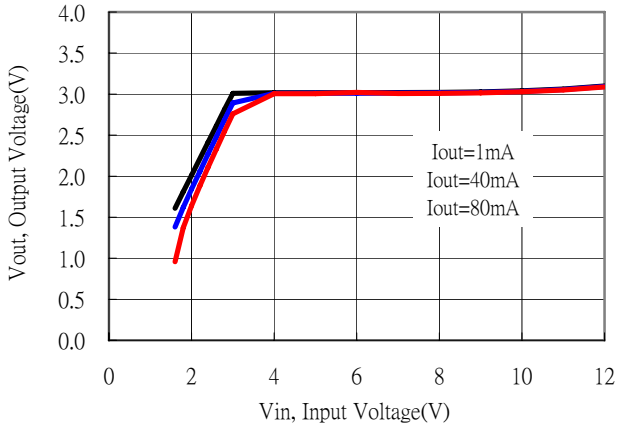

Input-Output Voltage Differential

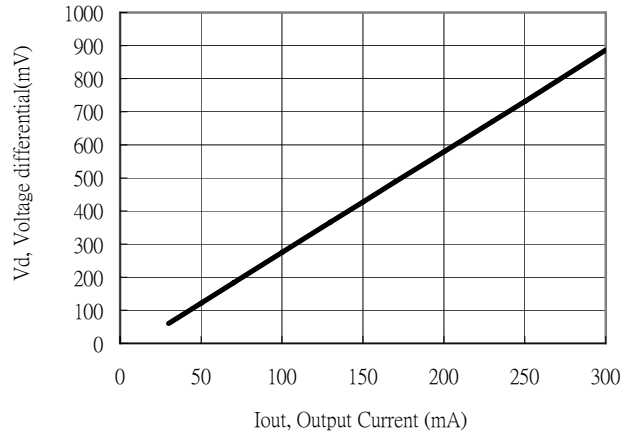

Supply Current vs Input Voltage

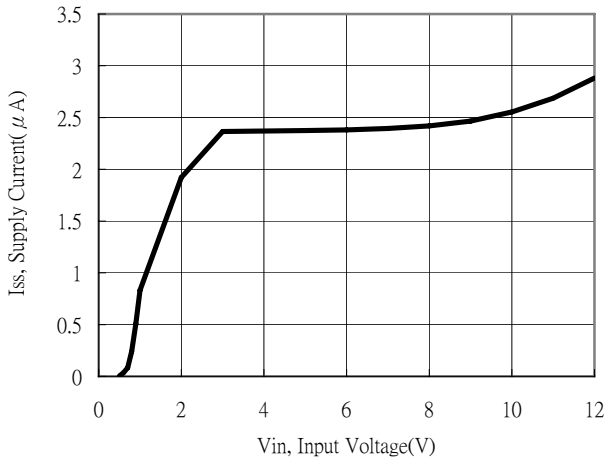

**LM1114-3.3**

Output Voltage vs Input Voltage

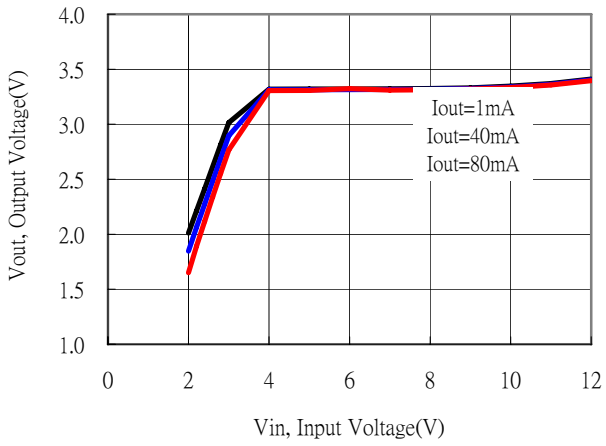

Input-Output Voltage Differential

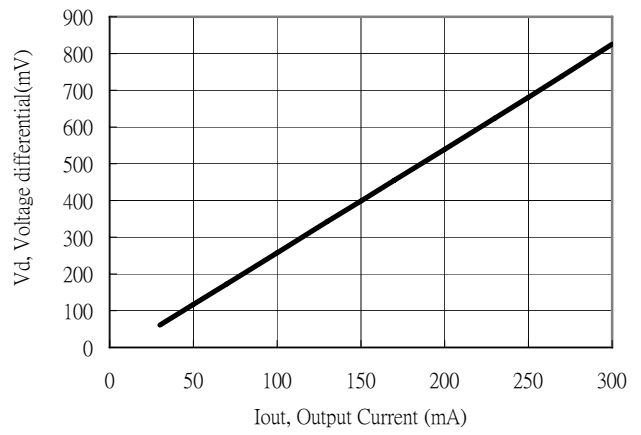

Supply Current vs Input Voltage

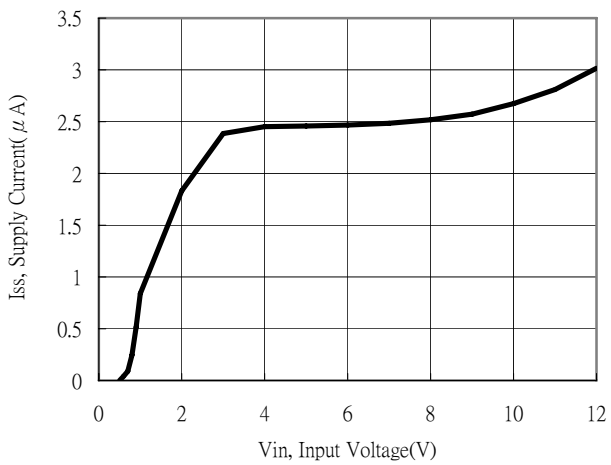

**LM1114-5.0**

Output Voltage vs Input Voltage

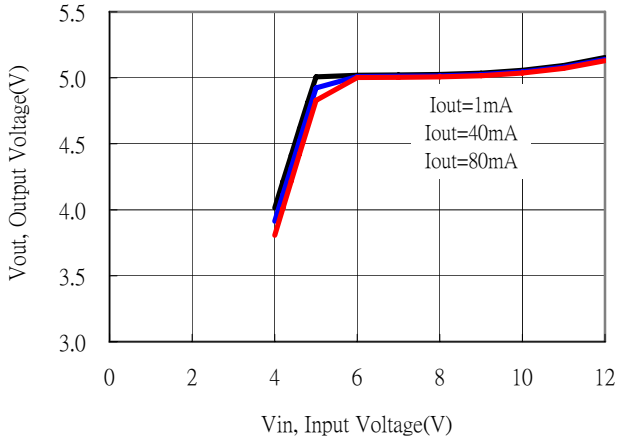

Input-Output Voltage Differential

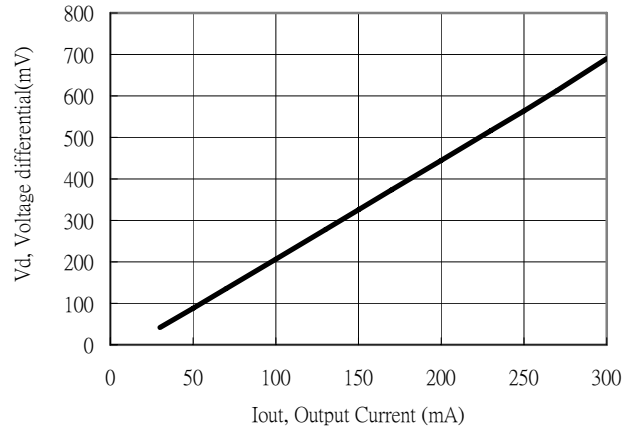

Supply Current vs Input Voltage

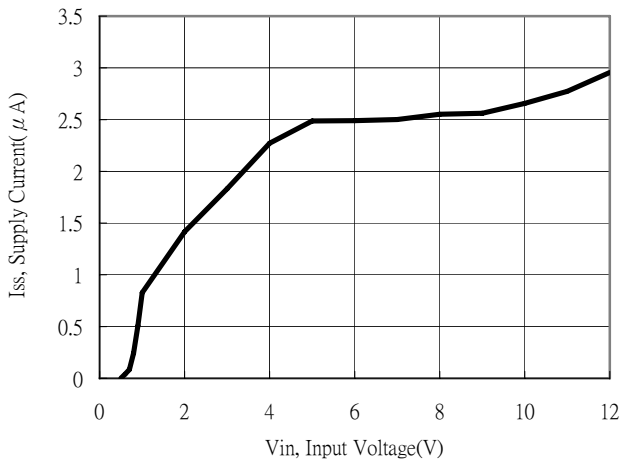



**Recommended wave soldering condition**

Product	Peak Temperature	Soldering Time
Pb-free devices	260 +0/-5 °C	5 +1/-1 seconds

**Recommended temperature profile for IR reflow**

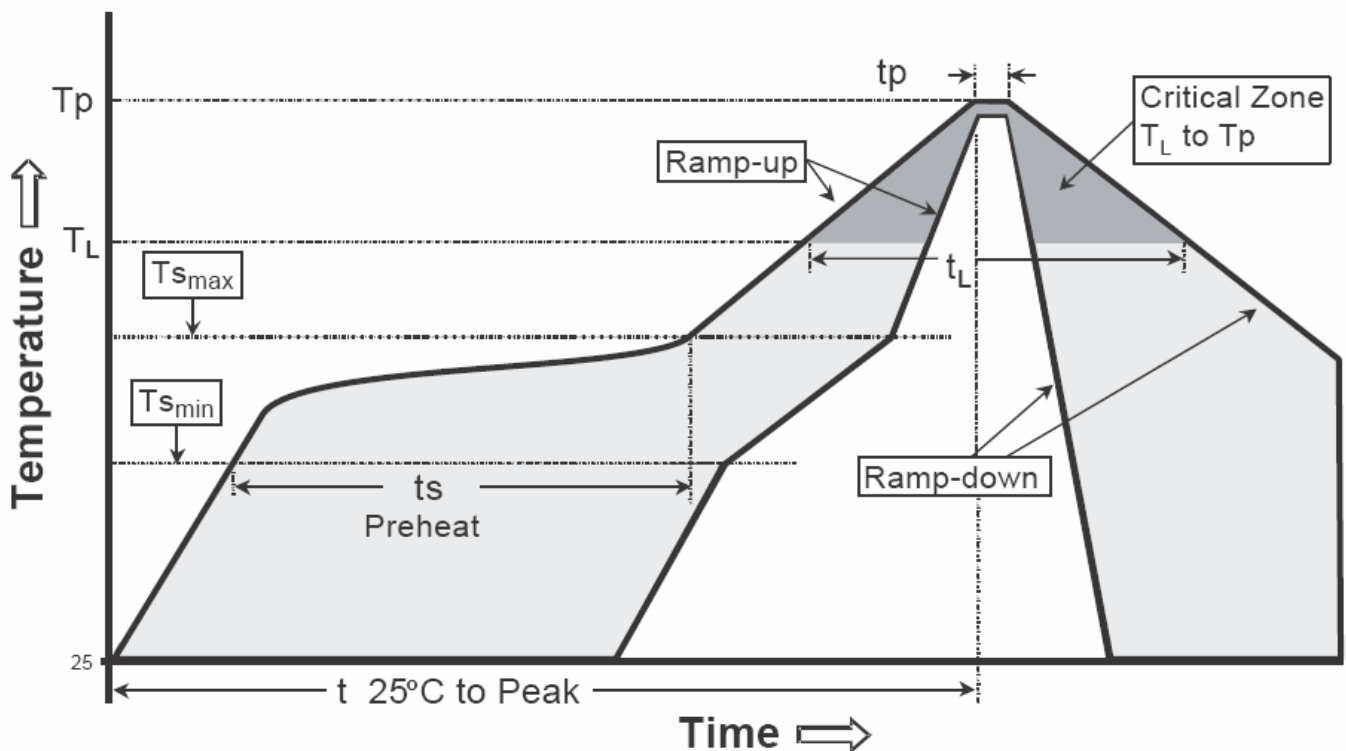

Profile feature	Sn-Pb eutectic Assembly	Pb-free Assembly
Average ramp-up rate (Tsmax to Tp)	3°C/second max.	3°C/second max.
Preheat		
-Temperature Min(Ts min)	100°C	150°C
-Temperature Max(Ts max)	150°C	200°C
-Time(ts min to ts max)	60-120 seconds	60-180 seconds
Time maintained above:		
-Temperature (Tl)	183°C	217°C
- Time (tL)	60-150 seconds	60-150 seconds
Peak Temperature(Tp)	240 +0/-5 °C	260 +0/-5 °C
Time within 5°C of actual peak temperature(tp)	10-30 seconds	20-40 seconds
Ramp down rate	6°C/second max.	6°C/second max.
Time 25 °C to peak temperature	6 minutes max.	8 minutes max.

Note : All temperatures refer to topside of the package, measured on the package body surface.

**TO-92 Taping Outline**

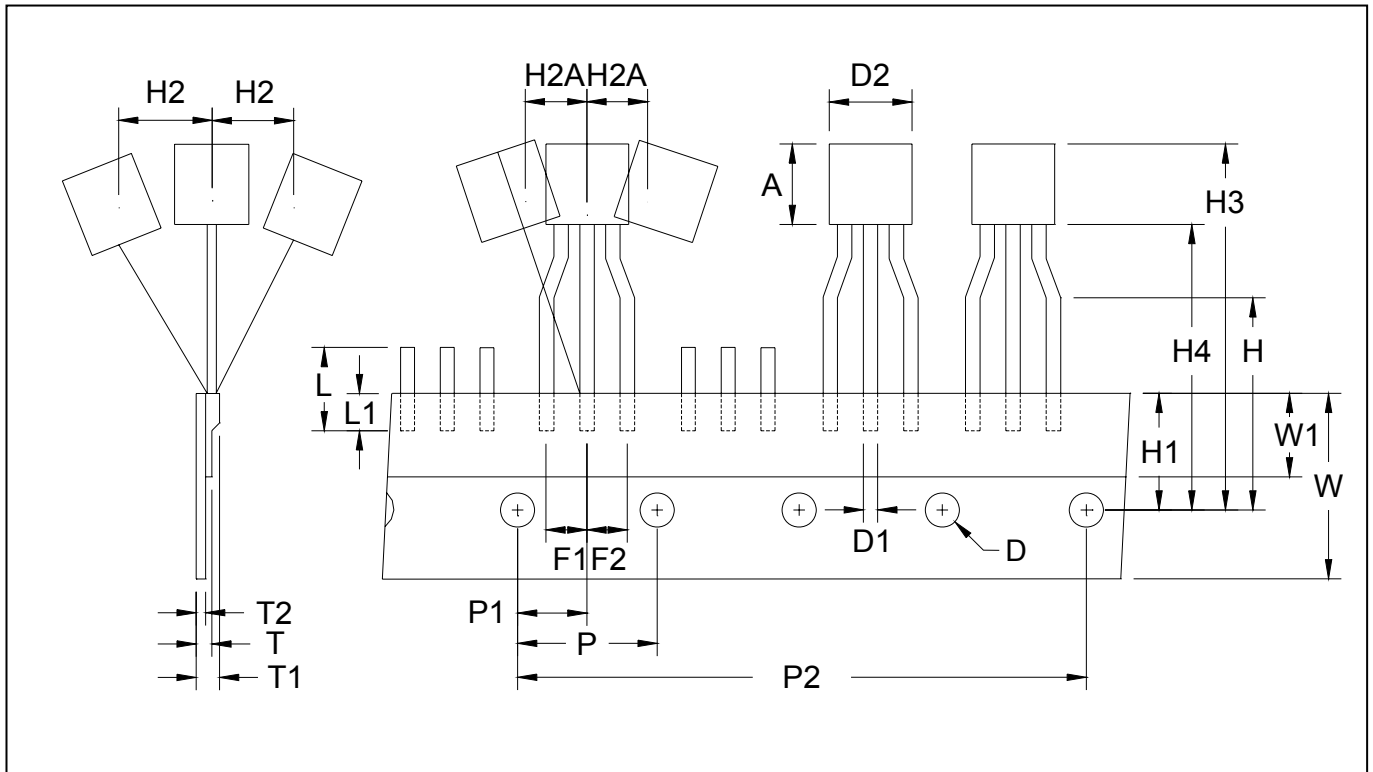

DIM	Item	Millimeters	
		Min.	Max.
A	Component body height	4.33	4.83
D	Tape Feed Diameter	3.80	4.20
D1	Lead Diameter	0.36	0.53
D2	Component Body Diameter	4.33	4.83
F1,F2	Component Lead Pitch	2.40	2.90
F1,F2	F1-F2	-	±0.3
H	Height Of Seating Plane	15.50	16.50
H1	Feed Hole Location	8.50	9.50
H2	Front To Rear Deflection	-	1
H2A	Deflection Left Or Right	-	1
H3	Component Height	-	27
H4	Feed Hole To Bottom Of Component	-	21
L	Lead Length After Component Removal	-	11
L1	Lead Wire Enclosure	2.50	-
P	Feed Hole Pitch	12.50	12.90
P1	Center Of Seating Plane Location	5.95	6.75
P2	4 Feed Hole Pitch	50.30	51.30
T	Over All Tape Thickness	-	0.55
T1	Total Taped Package Thickness	-	1.42
T2	Carrier Tape Thickness	0.36	0.68
W	Tape Width	17.50	19.00
W1	Adhesive Tape Width	5.00	7.00
-	20 pcs Pitch	253	255



**Reel Dimension for SOT-89**

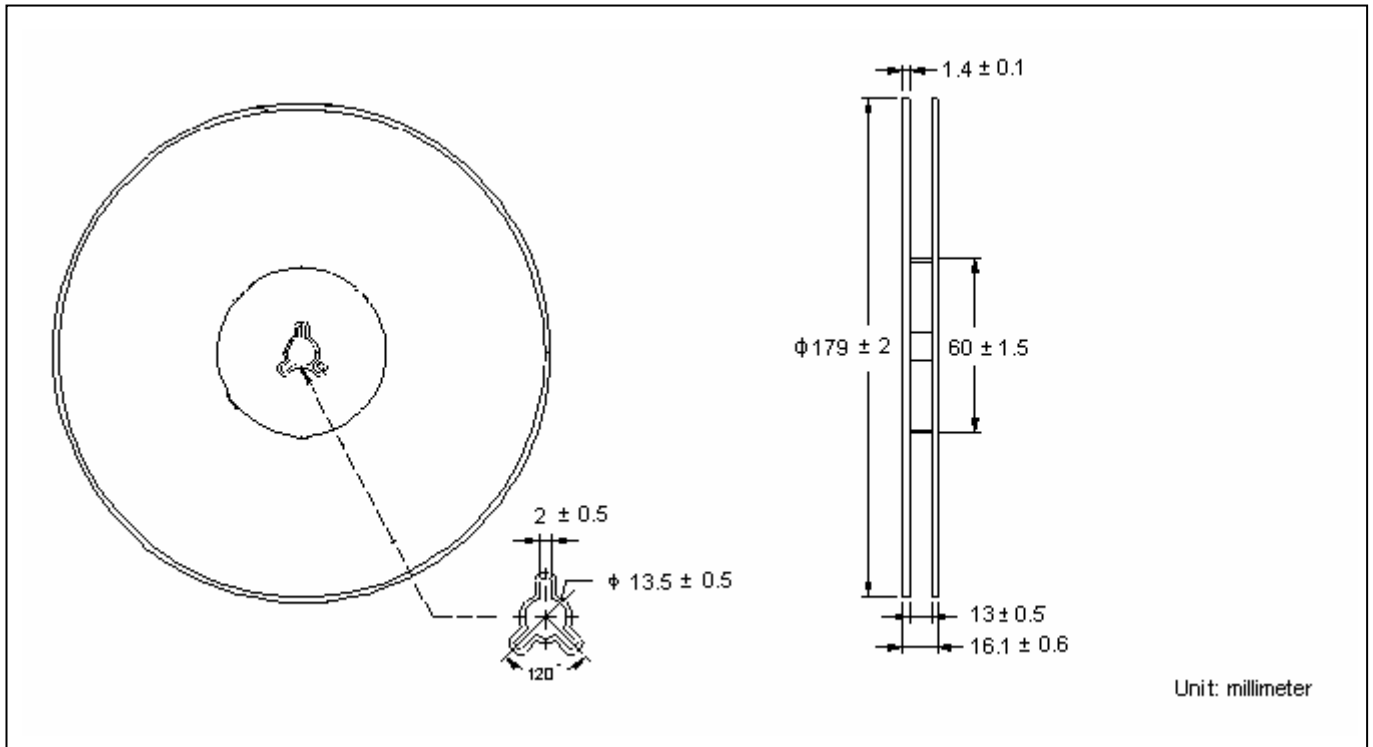

**Carrier Tape Dimension**

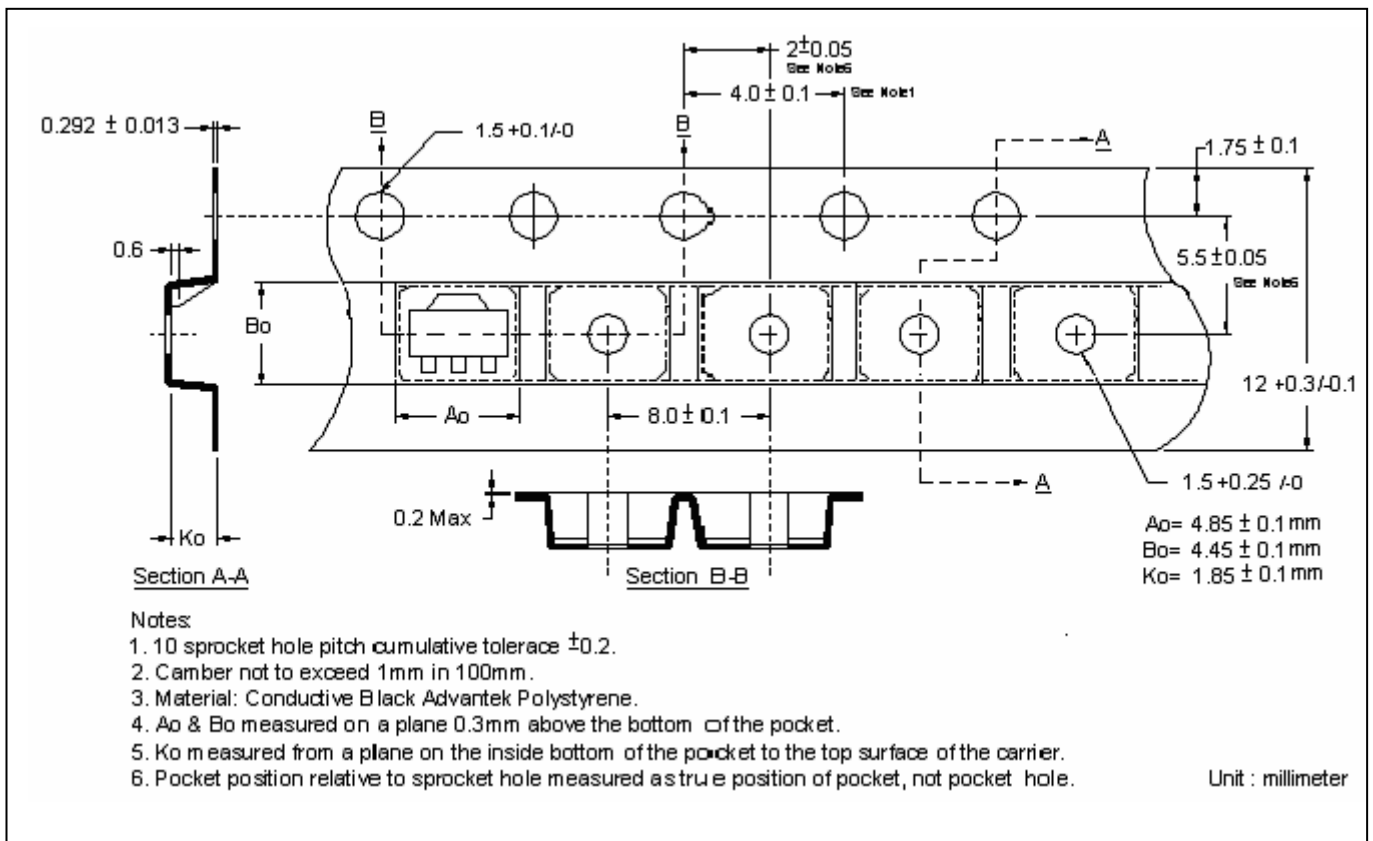

**TO-92 Dimension**

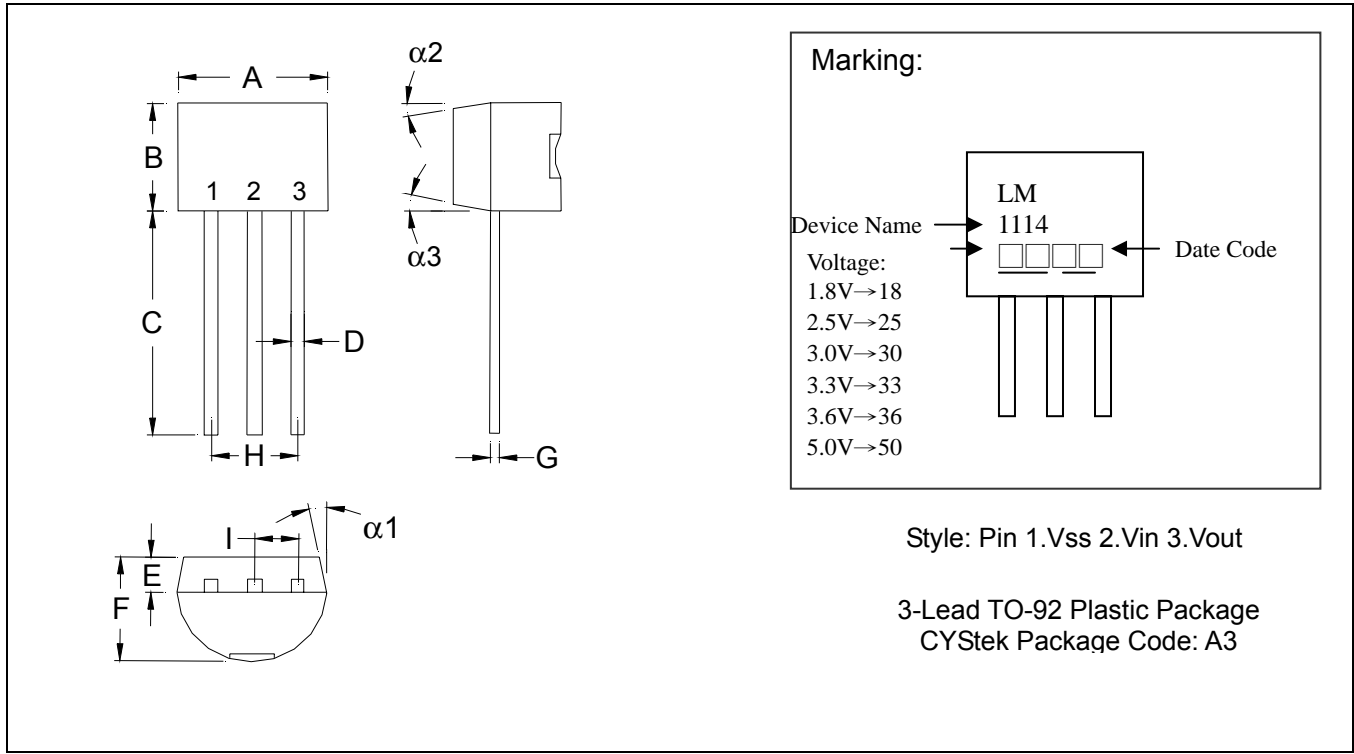

\*: Typical

DIM	Inches		Millimeters		DIM	Inches		Millimeters	
	Min.	Max.	Min.	Max.		Min.	Max.	Min.	Max.
A	0.1704	0.1902	4.33	4.83	G	0.0142	0.0220	0.36	0.56
B	0.1704	0.1902	4.33	4.83	H	-	*0.1000	-	*2.54
C	0.5000	-	12.70	-	I	-	*0.0500	-	*1.27
D	0.0142	0.0220	0.36	0.56	$\alpha 1$	-	*5°	-	*5°
E	-	*0.0500	-	*1.27	$\alpha 2$	-	*2°	-	*2°
F	0.1323	0.1480	3.36	3.76	$\alpha 3$	-	*2°	-	*2°

- Notes: 1.Dimension and tolerance based on our Spec. dated Apr. 18,2002.  
 2.Controlling dimension: millimeters.  
 3.Maximum lead thickness includes lead finish thickness, and minimum lead thickness is the minimum thickness of base material.  
 4.If there is any question with packing specification or packing method, please contact your local CYStek sales office.

**Material:**

- Lead: Pure tin plated.
- Mold Compound: Epoxy resin family, flammability solid burning class: UL94V-0.

**SOT-23 Dimension**

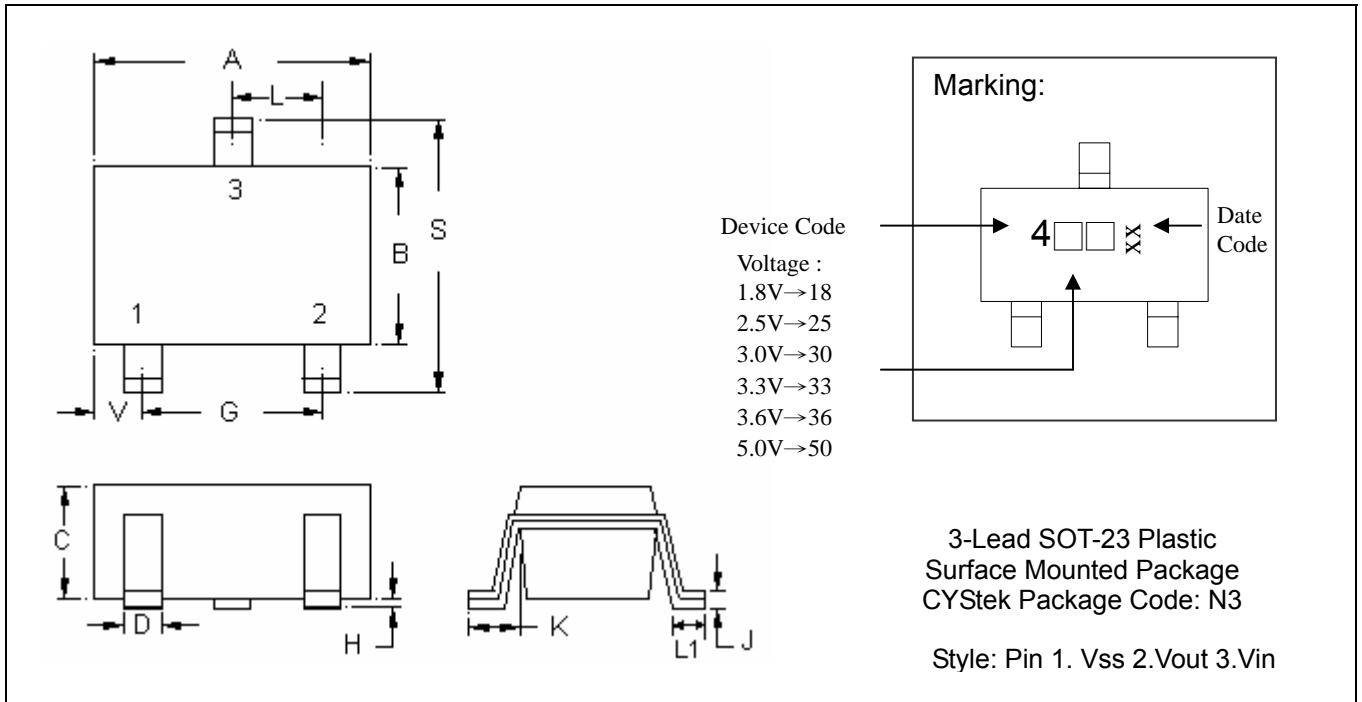

\*: Typical

DIM	Inches		Millimeters		DIM	Inches		Millimeters	
	Min.	Max.	Min.	Max.		Min.	Max.	Min.	Max.
A	0.1102	0.1204	2.80	3.04	J	0.0032	0.0079	0.08	0.20
B	0.0472	0.0669	1.20	1.70	K	0.0118	0.0266	0.30	0.67
C	0.0335	0.0512	0.89	1.30	L	0.0335	0.0453	0.85	1.15
D	0.0118	0.0197	0.30	0.50	S	0.0830	0.1161	2.10	2.95
G	0.0669	0.0910	1.70	2.30	V	0.0098	0.0256	0.25	0.65
H	0.0000	0.0040	0.00	0.10	L1	0.0118	0.0197	0.30	0.50

- Notes:** 1.Dimension and tolerance based on our Spec. dated Feb. 18,2002.  
 2.Controlling dimension: millimeters.  
 3.Maximum lead thickness includes lead finish thickness, and minimum lead thickness is the minimum thickness of base material.  
 4.If there is any question with packing specification or packing method, please contact your local CYCtek sales office.

**Material:**

- Lead: Pure tin plated.
- Mold Compound: Epoxy resin family, flammability solid burning class: UL94V-0.

**SOT-89 Dimension**

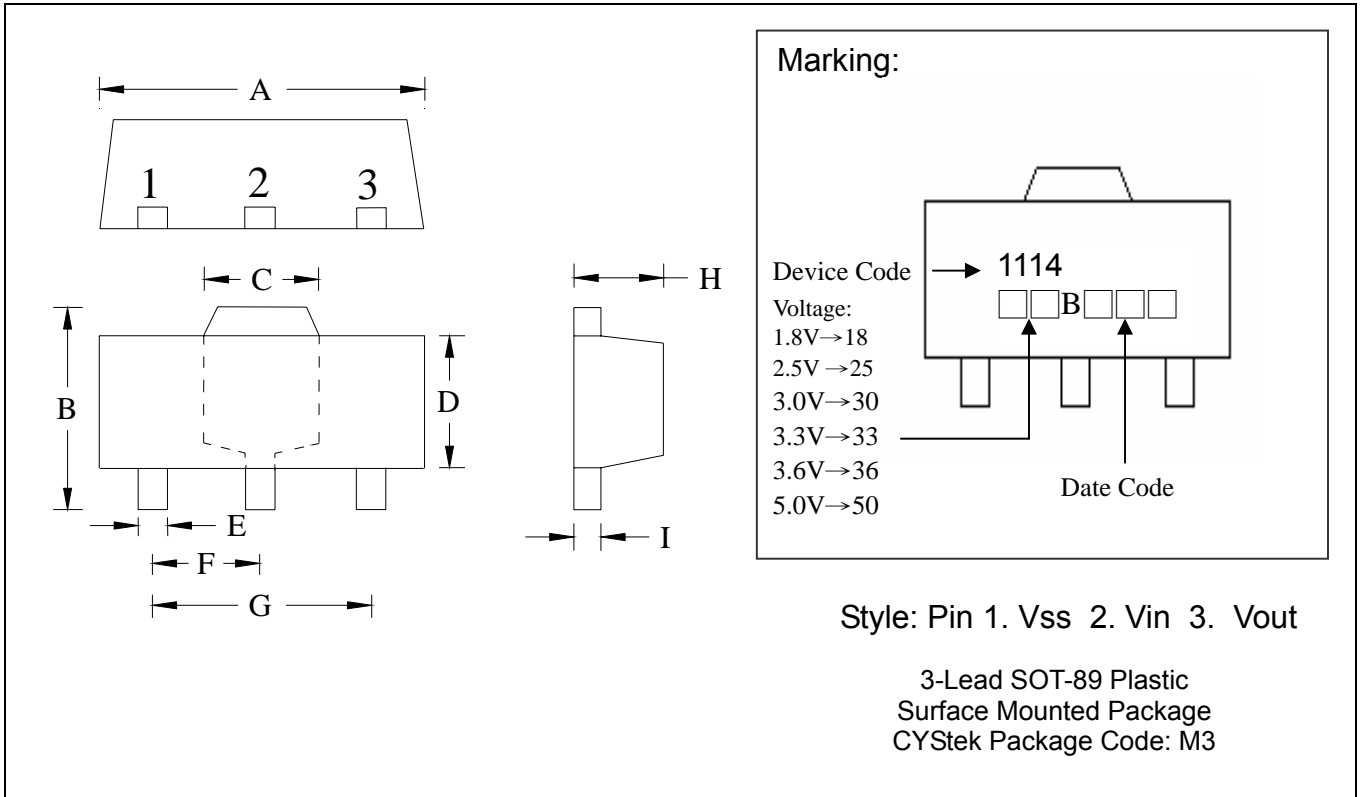

\*: Typical

DIM	Inches		Millimeters		DIM	Inches		Millimeters	
	Min.	Max.	Min.	Max.		Min.	Max.	Min.	Max.
A	0.1732	0.1811	4.40	4.60	F	0.0583	0.0598	1.48	1.527
B	0.1594	0.1673	4.05	4.25	G	0.1165	0.1197	2.96	3.04
C	0.0591	0.0663	1.50	1.70	H	0.0551	0.0630	1.40	1.60
D	0.0945	0.1024	2.40	2.60	I	0.0138	0.0161	0.35	0.41
E	0.01417	0.0201	0.36	0.51					

- Notes:** 1. Controlling dimension: millimeters.  
 2. Maximum lead thickness includes lead finish thickness, and minimum lead thickness is the minimum thickness of base material.  
 3. If there is any question with packing specification or packing method, please contact your local CYStek sales office.

**Material:**

- Lead: Pure tin plated.
- Mold Compound: Epoxy resin family, flammability solid burning class: UL94V-0.

**Important Notice:**

- All rights are reserved. Reproduction in whole or in part is prohibited without the prior written approval of CYStek.
- CYStek reserves the right to make changes to its products without notice.
- CYStek **semiconductor products are not warranted to be suitable for use in Life-Support Applications, or systems.**
- CYStek assumes no liability for any consequence of customer product design, infringement of patents, or application assistance.