



## 14N50

Preliminary

Power MOSFET

### 14A, 500V N-CHANNEL POWER MOSFET

#### DESCRIPTION

The UTC **14N50** is an N-Channel enhancement mode power MOSFET. The device adopts planar stripe and uses DMOS technology to minimize and provide lower on-state resistance and faster switching speed. It can also withstand high energy pulse under the avalanche and commutation mode conditions.

The UTC **14N50** is ideally suitable for high efficiency switch mode power supply, power factor correction and electronic lamp ballast based on half bridge topology.

#### FEATURES

- \*  $R_{DS(ON)} < 0.42\Omega @ V_{GS} = 10V$
- \* Ultra low gate charge (typical 43nC )
- \* Low reverse transfer Capacitance (  $C_{RSS} =$  typical 20pF )
- \* Fast switching capability
- \* Avalanche energy tested
- \* Improved dv/dt capability, high ruggedness

#### SYMBOL

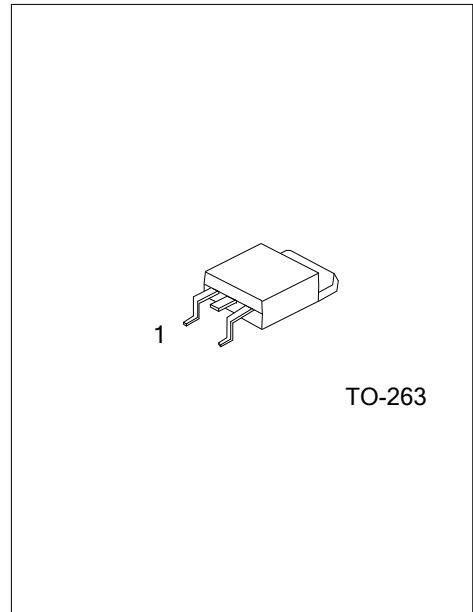
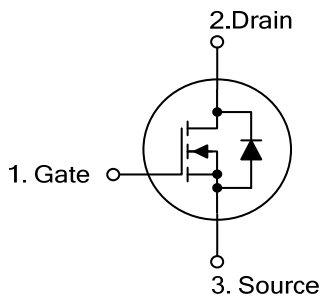

#### ORDERING INFORMATION

Ordering Number		Package	Pin Assignment			Packing
Lead Free	Halogen Free		1	2	3	
14N50L-TQ2-T	14N50G-TQ2-T	TO-263	G	D	S	Tube
14N50L-TQ2-R	14N50G-TQ2-R	TO-263	G	D	S	Tape Reel

Note: Pin Assignment: G: Gate D: Drain S: Source

<p>14N50L-TQ2-T</p> <p>(1)Packing Type (2)Package Type (3)Green Package</p>	<p>(1) T: Tube (2) TQ2: TO-263 (3) L: Lead Free, G: Halogen Free and Lead Free</p>
---	--

### MARKING

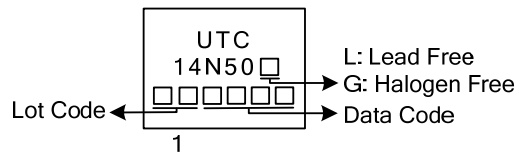

■ ABSOLUTE MAXIMUM RATINGS ( $T_C = 25^\circ\text{C}$ , unless otherwise specified)

PARAMETER	SYMBOL	RATINGS	UNIT
Drain-Source Voltage	$V_{DSS}$	500	V
Gate-Source Voltage	$V_{GSS}$	$\pm 30$	V
Continuous Drain Current	$I_D$	14	A
Pulsed Drain Current (Note 2)	$I_{DM}$	48	A
Avalanche Current (Note 2)	$I_{AR}$	14	A
Single Pulsed Avalanche Energy (Note 3)	$E_{AS}$	400	mJ
Peak Diode Recovery dv/dt (Note 4)	dv/dt	4.5	V/ns
Power Dissipation ( $T_C=25^\circ\text{C}$ )	$P_D$	150	W
Junction Temperature	$T_J$	+150	$^\circ\text{C}$
Storage Temperature	$T_{STG}$	-55~+150	$^\circ\text{C}$

Notes: 1. Absolute maximum ratings are those values beyond which the device could be permanently damaged.

Absolute maximum ratings are stress ratings only and functional device operation is not implied.

2. Repetitive Rating : Pulse width limited by maximum junction temperature.

3.  $L = 9.3\text{mH}$ ,  $I_{AS} = 13\text{A}$ ,  $V_{DD} = 50\text{V}$ ,  $R_G = 25\Omega$ , Starting  $T_J = 25^\circ\text{C}$

4.  $I_{SD} \leq 13\text{A}$ ,  $di/dt \leq 200\text{A}/\mu\text{s}$ ,  $V_{DD} \leq BV_{DSS}$ , Starting  $T_J = 25^\circ\text{C}$

■ THERMAL DATA

PARAMETER	SYMBOL	RATINGS	UNIT
Junction to Ambient	$\theta_{JA}$	62.5	$^\circ\text{C}/\text{W}$
Junction to Case	$\theta_{JC}$	0.83	$^\circ\text{C}/\text{W}$

■ ELECTRICAL CHARACTERISTICS ( $T_C=25^\circ\text{C}$ , unless otherwise specified)

PARAMETER	SYMBOL	TEST CONDITIONS	MIN	TYP	MAX	UNIT	
<b>OFF CHARACTERISTICS</b>							
Drain-Source Breakdown Voltage	$BV_{DSS}$	$V_{GS} = 0V, I_D = 1mA$	500			V	
Drain-Source Leakage Current	$I_{DSS}$	$V_{DS} = 500V, V_{GS} = 0V$			10	$\mu A$	
Gate-Source Leakage Current	$I_{GSS}$	$V_{GS} = 20V, V_{DS} = 0V$			100	nA	
		$V_{GS} = -20V, V_{DS} = 0V$			-100	nA	
Breakdown Voltage Temperature Coefficient	$\Delta BV_{DSS}/\Delta T_J$	$I_D=250mA, \text{Referenced to } 25^\circ\text{C}$		0.5		$V/^\circ\text{C}$	
<b>ON CHARACTERISTICS</b>							
Gate Threshold Voltage	$V_{GS(TH)}$	$V_{DS} = V_{GS}, I_D = 100\mu A$	3	3.75	4.5	V	
Static Drain-Source On-State Resistance	$R_{DS(ON)}$	$V_{GS} = 10V, I_D = 7A$		0.34	0.42	$\Omega$	
<b>DYNAMIC CHARACTERISTICS</b>							
Input Capacitance	$C_{ISS}$	$V_{DS}=25V, V_{GS}=0V,$ $f=1.0MHz$		2000		pF	
Output Capacitance	$C_{OSS}$				238		pF
Reverse Transfer Capacitance	$C_{RSS}$				55		pF
<b>SWITCHING CHARACTERISTICS</b>							
Total Gate Charge	$Q_G$	$V_{DS}=400V, I_D=12A,$ $V_{GS}=10V \text{ (Note 1,2)}$		69	92	nC	
Gate-Source Charge	$Q_{GS}$				12		nC
Gate-Drain Charge	$Q_{GD}$				31		nC
Turn-On Delay Time	$t_{D(ON)}$	$V_{DD} = 250V, I_D = 14A,$ $R_G = 25\Omega \text{ (Note 1,2)}$		24		nS	
Turn-On Rise Time	$t_R$				70		nS
Turn-Off Delay Time	$t_{D(OFF)}$				54		nS
Turn-Off Fall Time	$t_F$				50		nS
<b>DRAIN-SOURCE DIODE CHARACTERISTICS AND MAXIMUM RATINGS</b>							
Drain-Source Diode Forward Voltage	$V_{SD}$	$V_{GS} = 0V, I_S = 14A$			1.6	V	
Maximum Continuous Drain-Source Diode Forward Current	$I_S$				14	A	
Maximum Pulsed Drain-Source Diode Forward Current	$I_{SM}$				56	A	
Reverse Recovery Time	$t_{rr}$	$V_{GS} = 0V, I_S = 14A,$ $di_F / dt = 100A/\mu s \text{ (Note 1)}$		470		nS	
Reverse Recovery Charge	$Q_{RR}$				3.1		$\mu C$

Notes: 1. Pulse Test : Pulse width  $\leq 300\mu s$ , Duty cycle  $\leq 2\%$ .

2. Essentially independent of operating ambient temperature.

■ TEST CIRCUITS AND WAVEFORMS

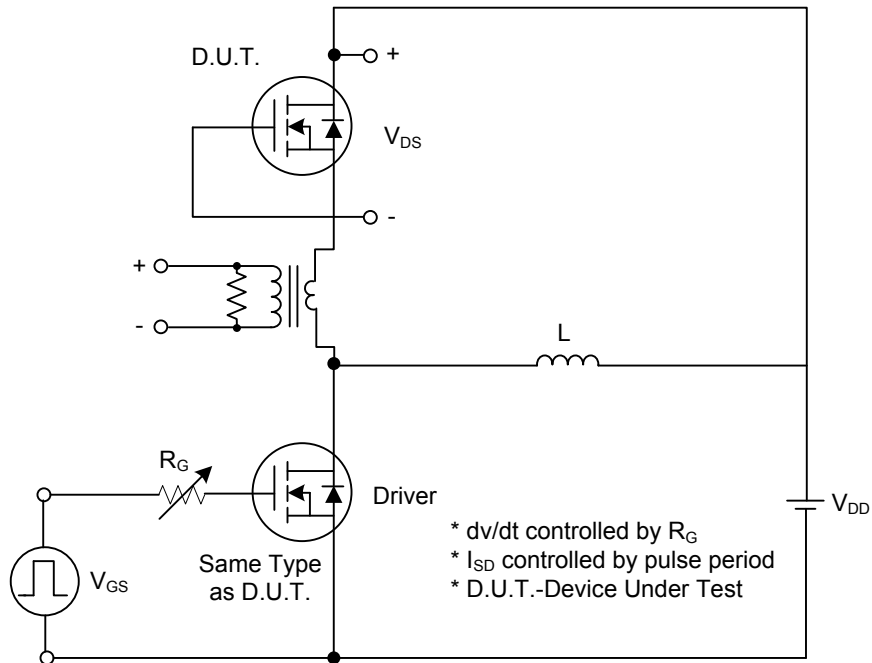

Peak Diode Recovery  $dv/dt$  Test Circuit

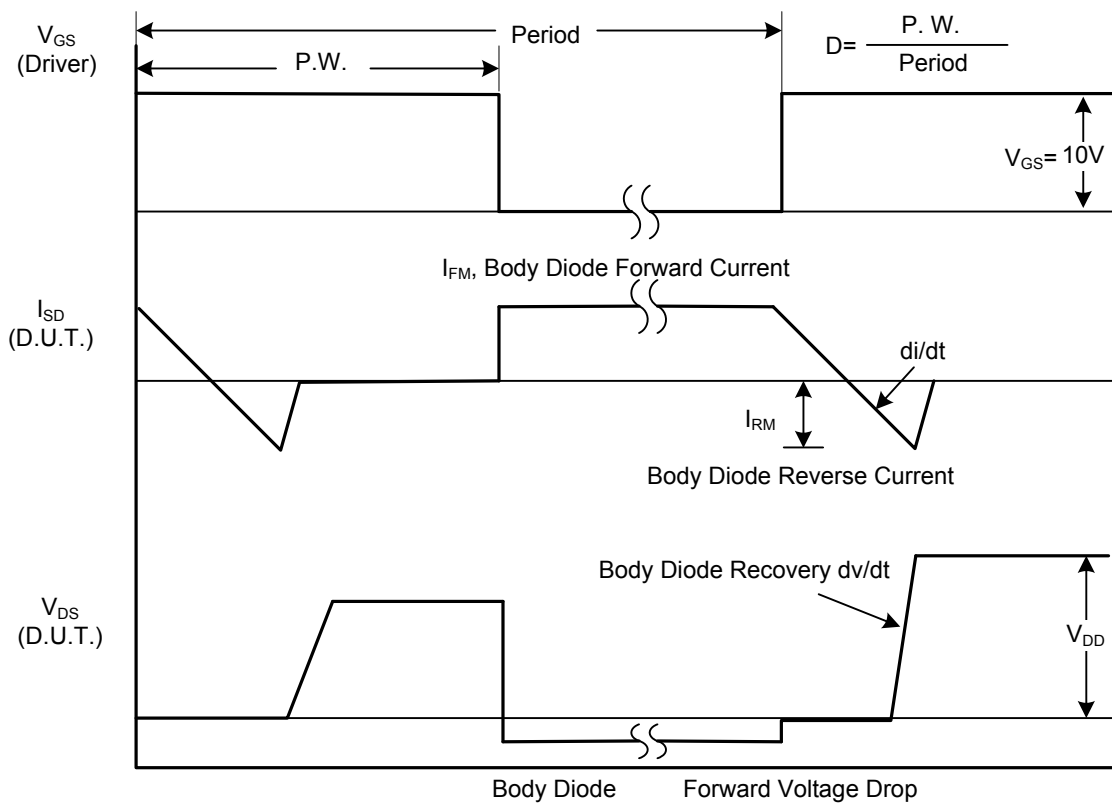

Peak Diode Recovery  $dv/dt$  Waveforms

■ TEST CIRCUITS AND WAVEFORMS (Cont.)

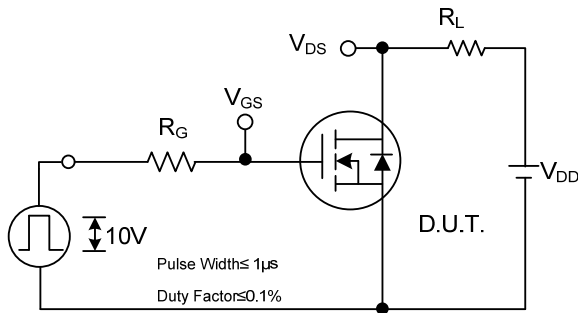

Switching Test Circuit

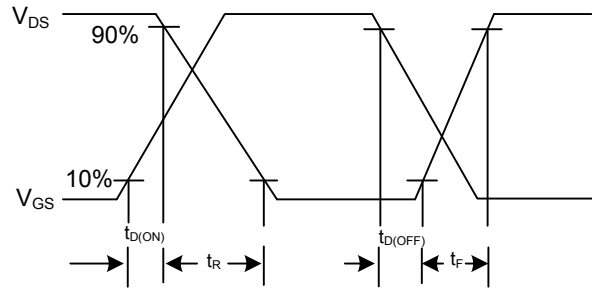

Switching Waveforms

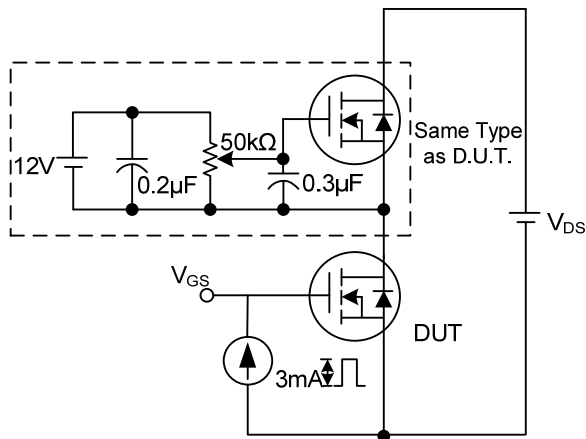

Gate Charge Test Circuit

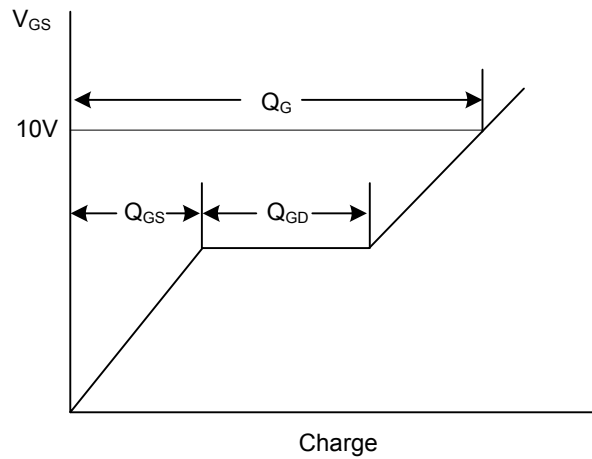

Gate Charge Waveform

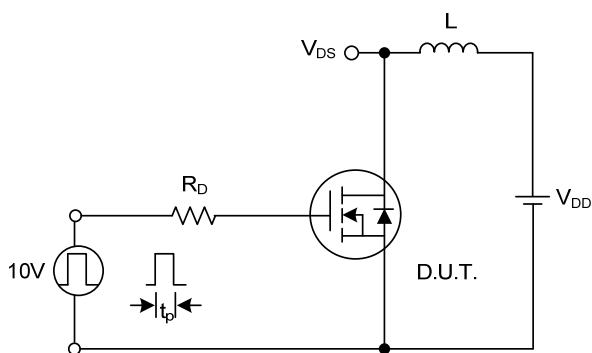

Unclamped Inductive Switching Test Circuit

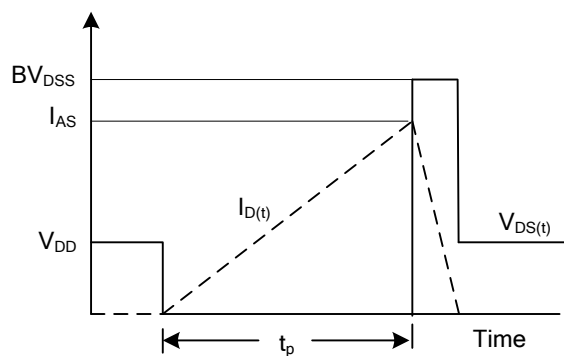

Unclamped Inductive Switching Waveforms

UTC assumes no responsibility for equipment failures that result from using products at values that exceed, even momentarily, rated values (such as maximum ratings, operating condition ranges, or other parameters) listed in products specifications of any and all UTC products described or contained herein. UTC products are not designed for use in life support appliances, devices or systems where malfunction of these products can be reasonably expected to result in personal injury. Reproduction in whole or in part is prohibited without the prior written consent of the copyright owner. The information presented in this document does not form part of any quotation or contract, is believed to be accurate and reliable and may be changed without notice.