

THIS DRAWING IS UNPUBLISHED. RELEASED FOR PUBLICATION 20
 © COPYRIGHT 20 BY - ALL RIGHTS RESERVED.

REVISIONS				
P	LTR	DESCRIPTION	DATE	APVD
	M	ECO-13-012991	14AUG2013	JM TE

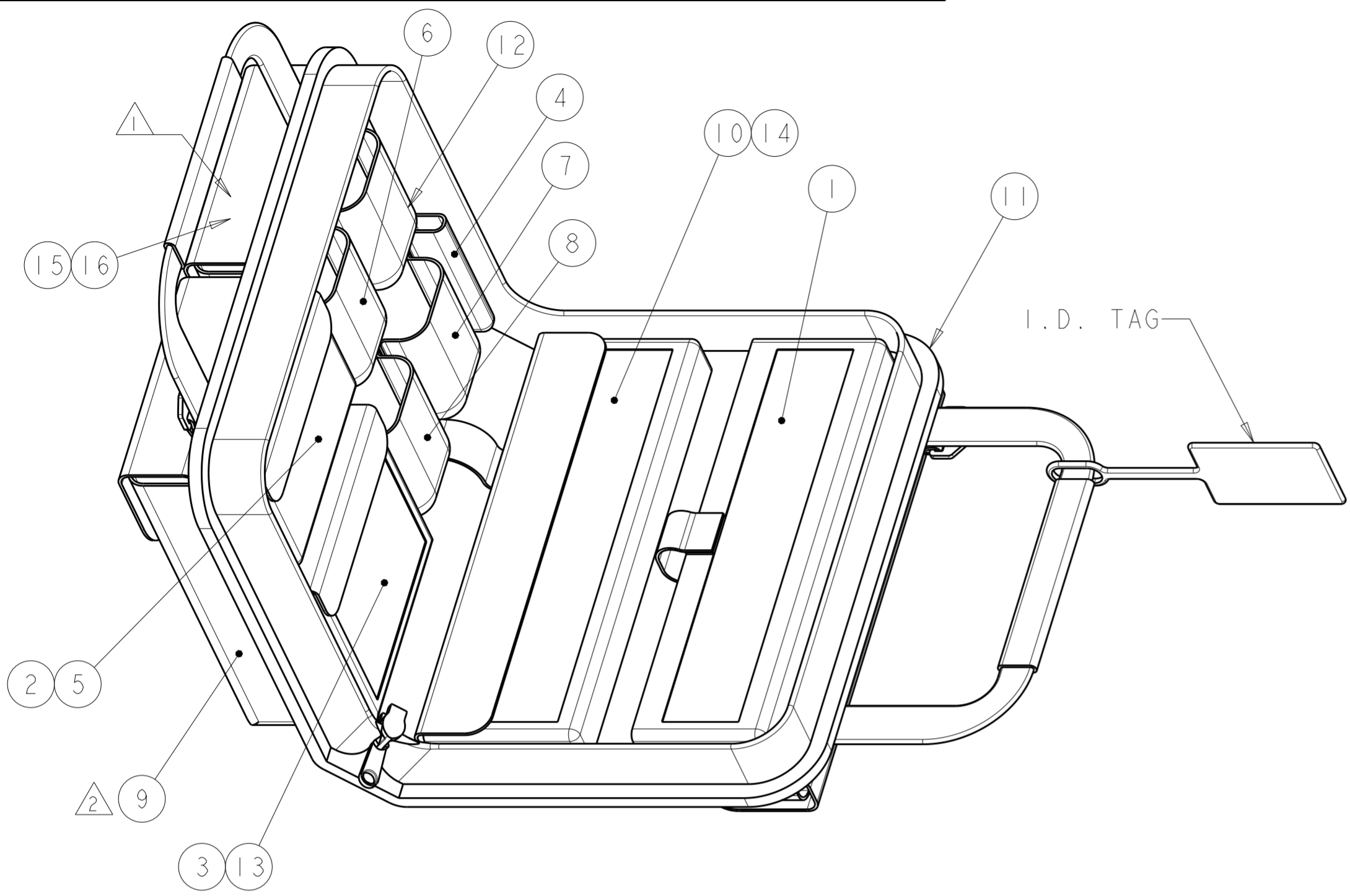

- 1 MANUFACTURER'S INSTRUCTION SHEETS.
- 2 OPTIONAL SHOULDER STRAP.
- 3. INSTRUCTION SHEETS 408-4020, 408-8925, 408-4471 AND 408-10103 EXPLAIN THE LightCrimp Plus TERMINATION TECHNIQUE AND ARE AVAILABLE FOR DOWNLOAD AT www.tycoelectronics.com/documents OR www.ampnetconnect.com/foguide

1	1	2064710-1	FIBER OPTICS CLEANING & INSPECTION GUIDE	16
1	1	1374503-1	CD ROM, TERMINATION TRAINING	15
1	-	1754765-1	MICROSCOPE ADAPTER, 1.25mm	14
1	1	1278625-1	CABLE CLAMP	13
1	1	1553661-1	SLITTER TOOL, 2mm & 3mm	12
1	1	1278540-1	PREMIUM SOFT CASE	11
1	-	1754767-1	200x MICROSCOPE KIT	10
1	1	1871696-1	FIBER CLEAVER, SLIDE CUTTER	9
1	1	1278637-1	ARAMID YARN SHEARS	8
1	1	1754708-1	FIBER STRIP TOOL, COMBINATION	7
1	1	492109-2	MICRO STRIP TOOL MT-RJ (.008IN)	6
14	14	501857-2	ALCOHOL WIPES	5
2	2	1278422-1	OPEN END WRENCH, 1/4IN	4
1	1	2064540-1	CABLE HOLDER, LightCrimp Plus/LC/SC	3
1	1	1985766-1	DIESET, LightCrimp Plus/LC/SC/SPLICE	2
1	1	1976850-2	HANDTOOL FRAME, BLACK	1
-2	-1	PART NUMBER	DESCRIPTION	ITEM NO.

THIS DRAWING IS A CONTROLLED DOCUMENT.		DWN B. BRIGGS 17MAY2006	STE TE Connectivity															
		CHK D. KIRSCH 17MAY2006																
		APVD S. BUCHTER 17MAY2006	NAME TERMINATION KIT, LightCrimp Plus, AMP SC/LC															
DIMENSIONS: mm		TOLERANCES UNLESS OTHERWISE SPECIFIED:		PRODUCT SPEC														
<table border="0"> <tr><td>0 PLC</td><td>±</td></tr> <tr><td>1 PLC</td><td>±</td></tr> <tr><td>2 PLC</td><td>±</td></tr> <tr><td>3 PLC</td><td>±</td></tr> <tr><td>4 PLC</td><td>±</td></tr> <tr><td>ANGLES</td><td>±</td></tr> <tr><td>FINISH</td><td>±</td></tr> </table>		0 PLC	±	1 PLC	±	2 PLC	±	3 PLC	±	4 PLC	±	ANGLES	±	FINISH	±	APPLICATION SPEC		SCALE
0 PLC	±																	
1 PLC	±																	
2 PLC	±																	
3 PLC	±																	
4 PLC	±																	
ANGLES	±																	
FINISH	±																	
MATERIAL		WEIGHT		SIZE A2														
		CUSTOMER DRAWING		CAGE CODE -														
				DRAWING NO. C-1754845														
				RESTRICTED TO -														
				SCALE NTS SHEET OF REV M														