



L3G462A

MEMS motion sensor: ± 625 dps full scale - 3-axis analog gyroscope

Preliminary data

Features

- ± 625 dps full scale
- Wide supply voltage range 2.4 V to 3.6 V
- Embedded power-down and sleep mode to save power consumption and shorten turn-on time
- Integrated temperature sensor
- Embedded low pass filter
- High shock survivability
- Extended operating temperature range (-40 °C to 85 °C)
- ECOPACK® RoHS and “Green” compliant

Applications

- Gaming and virtual reality input devices
- Motion control with MMI (man-machine interface)
- GPS navigation systems
- Appliances and robotics

Description

The L3G462A is a low-power 3-axis angular rate sensor.

It includes a sensing element and an IC interface able to provide the measured angular rate to the external world through three analog outputs.

The sensing element is manufactured using a dedicated micromachining process developed by ST to produce inertial sensors and actuators on silicon wafers.

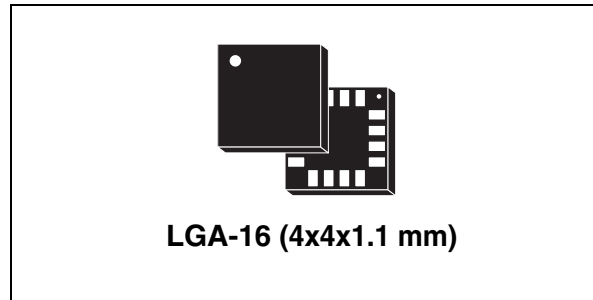

The IC interface is manufactured using a CMOS process that allows a high level of integration to design a dedicated circuit which is trimmed to better match the sensing element characteristics.

The L3G462A is available in a plastic land grid array (LGA) package and can operate within a temperature range from -40 °C to +85 °C.

Table 1. Device summary

Order code	Temperature range (°C)	Package	Packing
L3G462A	-40 to +85	LGA-16 (4x4x1.1)	Tray
L3G462ATR	-40 to +85	LGA-16 (4x4x1.1)	Tape and reel

Contents

- 1 Block diagram and pin description 3**
 - 1.1 Pin description 3

- 2 Mechanical and electrical specifications 4**
 - 2.1 Mechanical characteristics 4
 - 2.2 Electrical characteristics 5
 - 2.3 Absolute maximum ratings 6
 - 2.4 Terminology 7
 - 2.4.1 Sensitivity 7
 - 2.4.2 Zero-rate level 7
 - 2.5 Sleep mode and power-down mode 7
 - 2.6 Soldering information 7

- 3 Application hints 8**

- 4 Package information 9**

- 5 Revision history 10**

1 Block diagram and pin description

1.1 Pin description

Figure 1. Pin connection

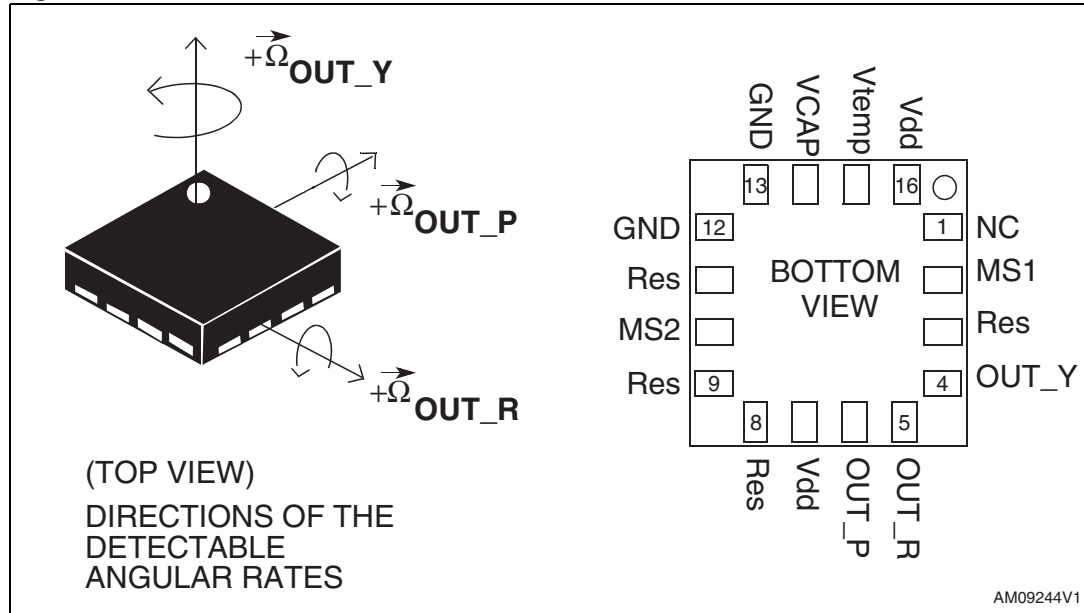

Table 2. Pin description

Pin#	Name	Function
1	NC	Internally not connected
2	MS1	Mode selection pin 1
3	Res	Reserved. Connect to GND
4	OUT_Y	Yaw axis angular rate output
5	OUT_R	Roll axis angular rate output
6	OUT_P	Pitch axis angular rate output
7	Vdd	Power supply
8	Res	Reserved. Leave unconnected
9	Res	Reserved. Leave unconnected
10	MS2	Mode selection pin 2
11	Res	Reserved. Leave unconnected
12	GND	0 V supply voltage
13	GND	0 V supply voltage
14	CAP	Charge pump capacitor connection pin
15	Vtemp	Temperature sensor output
16	Vdd	Power supply

2 Mechanical and electrical specifications

2.1 Mechanical characteristics

V_{dd} = 3.0 V, T = 25 °C unless otherwise noted ^(a)

Table 3. Mechanical characteristics

Symbol	Parameter	Test condition	Min.	Typ. ⁽¹⁾	Max.	Unit
FS	Measurement range			±625		dps
So	Sensitivity			2		mV/dps
SoDr	Sensitivity change vs. temperature			±0.017		%/°C
Zrl	Zero-rate level			1.5		V
OffDr	Zero-rate level change vs. temperature ⁽²⁾			±0.04		dps/°C
NL	Non linearity ⁽³⁾	Best fit straight line		0.5		% FS
Rn	Rate noise density			0.017		dps/ $\sqrt{\text{Hz}}$
BW	Bandwidth			140		Hz
TSo	Temperature sensor sensitivity			-2		mV/°C
TOff	Temperature sensor offset	27 °C		640		mV
TonPD	Turn-on time	From PD to normal mode		150		ms
TonSI	Turn-on time	From sleep to normal mode (no external filter applied)		10		ms
Top	Operating temperature range		-40		+85	°C

1. Typical specifications are not guaranteed.
2. Min. and max. values have been estimated based on the measurements of the current gyros in production.
3. Guaranteed by design.

a. The product is factory calibrated at 3.0 V. The operational power supply range is specified in [Table 4](#).

2.2 Electrical characteristics

V_{dd}=3.0 V, T=25 °C unless otherwise noted ^(b)

Table 4. Electrical characteristics

Symbol	Parameter	Test condition	Min.	Typ. ⁽¹⁾	Max.	Unit
V _{dd}	Supply voltage		2.4	3.0	3.6	V
I _{dd}	Supply current			6.9		mA
I _{ddSL}	Supply current in sleep mode ⁽²⁾	Selectable by digital interface		2		mA
I _{ddPdn}	Supply current in power-down mode	Selectable by digital interface		5		μA
Top	Operating temperature range		-40		+85	°C

1. Typical specifications are not guaranteed.
2. Sleep mode introduces a faster turn-on time related to power down mode.

b. The product is factory calibrated at 3.0 V.

2.3 Absolute maximum ratings

Stresses above those listed as “absolute maximum ratings” may cause permanent damage to the device. This is a stress rating only and functional operation of the device under these conditions is not implied. Exposure to maximum rating conditions for extended periods may affect device reliability.

Table 5. Absolute maximum ratings

Symbol	Ratings	Maximum value	Unit
Vdd	Supply voltage	-0.3 to 4.8	V
T _{STG}	Storage temperature range	-40 to +125	°C
Sg	Acceleration <i>g</i> for 0.1 ms	10,000	<i>g</i>
ESD	Electrostatic discharge protection	2 (HBM)	kV



This is a mechanical shock sensitive device, improper handling can cause permanent damage to the part.



This is an ESD sensitive device, improper handling can cause permanent damage to the part.

2.4 Terminology

2.4.1 Sensitivity

An angular rate gyroscope is a device that produces a positive-going digital output for counterclockwise rotation around the sensible axis considered. Sensitivity describes the gain of the sensor and can be determined by applying a defined angular velocity to it. This value changes very little over temperature and time.

2.4.2 Zero-rate level

Zero-rate level describes the actual output signal if there is no angular rate present. The zero-rate level of precise MEMS sensors is, to some extent, a result of stress to the sensor and therefore zero-rate level can slightly change after mounting the sensor onto a printed circuit board or after exposing it to extensive mechanical stress.

2.5 Sleep mode and power-down mode

The L3G462A enables advanced power saving functionalities thanks to the different operating modes available. When the device is set in sleep mode configuration, the reading chain is completely turned off, allowing low power consumption. In this condition the device turn-on time is significantly reduced allowing simple external power cycling.

The user can select the desired operating mode through two dedicated pins (MS1 and MS2).

Table 6. Sleep mode and power-down mode configuration

Operating mode	MS1	MS2
Normal mode	0	0
Power-down	1	1
Sleep mode	0	1

2.6 Soldering information

The LGA package is compliant with the ECOPACK[®] RoHS and “Green” standards. It is qualified for soldering heat resistance according to JEDEC J-STD-020.

Leave “Pin 1 Indicator” unconnected during soldering.

Land pattern and soldering recommendations are available at www.st.com/mems.

3 Application hints

Figure 2. L3G462A electrical connections and external component values

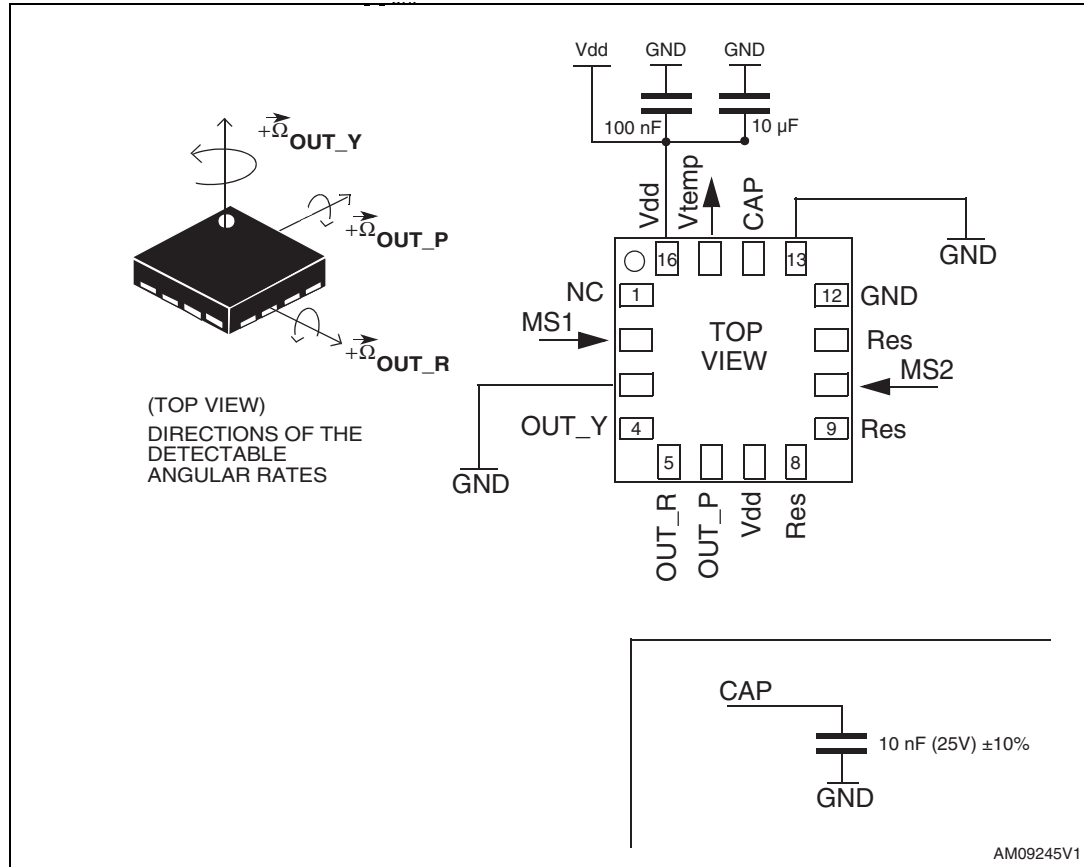

Power supply decoupling capacitors (100 nF ceramic or polyester + 10 μF aluminum) should be placed as near as possible to the device (common design practice). A 10 nF, 25 V class capacitor connected to pin 14 is required for proper working of the device.

4 Package information

In order to meet environmental requirements, ST offers these devices in different grades of ECOPACK® packages, depending on their level of environmental compliance. ECOPACK specifications, grade definitions, and product status are available at: www.st.com. ECOPACK is an ST trademark.

Figure 3. LGA-16: mechanical data and package dimensions

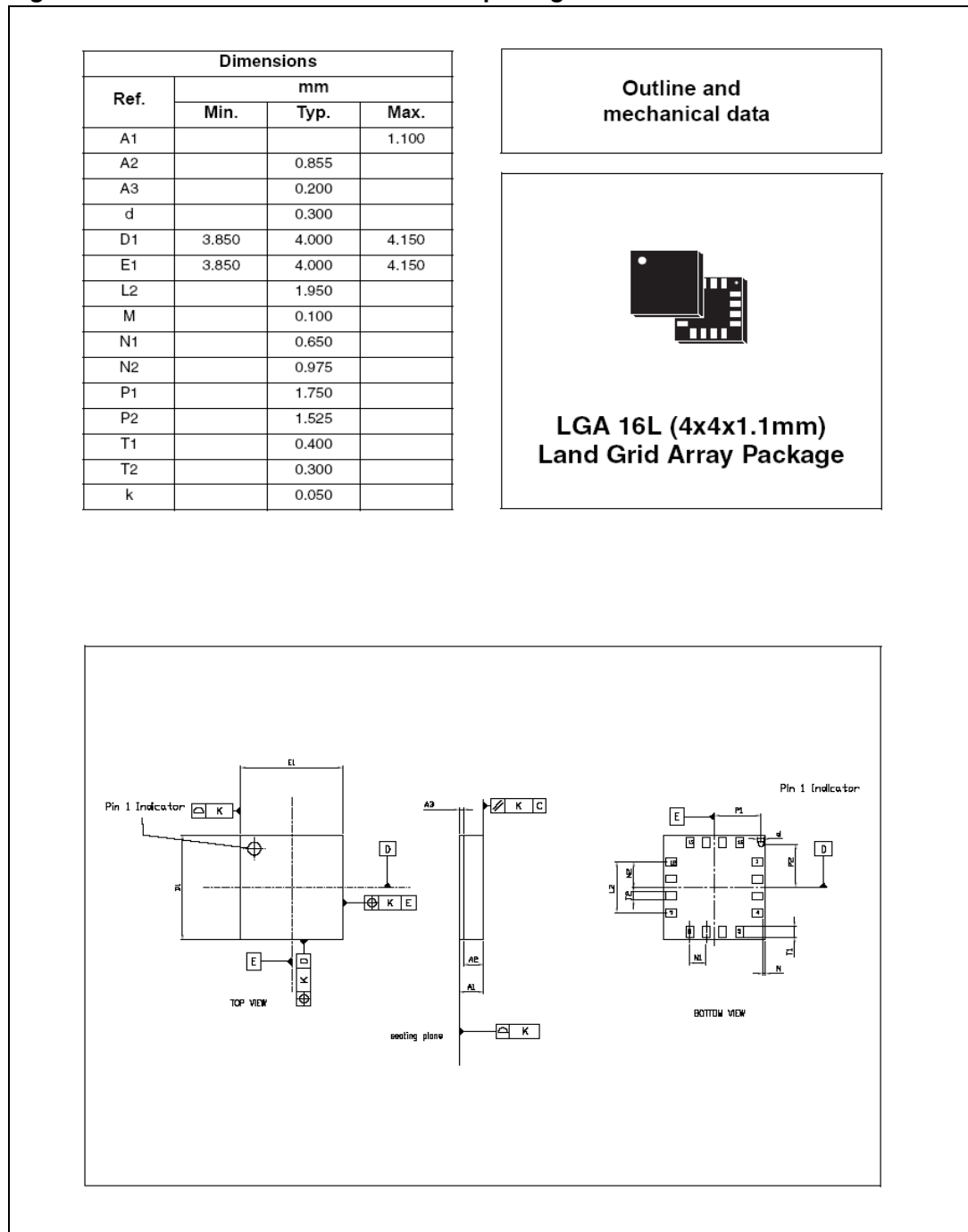

5 Revision history

Table 7. Document revision history

Date	Revision	Changes
15-Mar-2011	1	Initial release.

Please Read Carefully:

Information in this document is provided solely in connection with ST products. STMicroelectronics NV and its subsidiaries ("ST") reserve the right to make changes, corrections, modifications or improvements, to this document, and the products and services described herein at any time, without notice.

All ST products are sold pursuant to ST's terms and conditions of sale.

Purchasers are solely responsible for the choice, selection and use of the ST products and services described herein, and ST assumes no liability whatsoever relating to the choice, selection or use of the ST products and services described herein.

No license, express or implied, by estoppel or otherwise, to any intellectual property rights is granted under this document. If any part of this document refers to any third party products or services it shall not be deemed a license grant by ST for the use of such third party products or services, or any intellectual property contained therein or considered as a warranty covering the use in any manner whatsoever of such third party products or services or any intellectual property contained therein.

UNLESS OTHERWISE SET FORTH IN ST'S TERMS AND CONDITIONS OF SALE ST DISCLAIMS ANY EXPRESS OR IMPLIED WARRANTY WITH RESPECT TO THE USE AND/OR SALE OF ST PRODUCTS INCLUDING WITHOUT LIMITATION IMPLIED WARRANTIES OF MERCHANTABILITY, FITNESS FOR A PARTICULAR PURPOSE (AND THEIR EQUIVALENTS UNDER THE LAWS OF ANY JURISDICTION), OR INFRINGEMENT OF ANY PATENT, COPYRIGHT OR OTHER INTELLECTUAL PROPERTY RIGHT.

UNLESS EXPRESSLY APPROVED IN WRITING BY AN AUTHORIZED ST REPRESENTATIVE, ST PRODUCTS ARE NOT RECOMMENDED, AUTHORIZED OR WARRANTED FOR USE IN MILITARY, AIR CRAFT, SPACE, LIFE SAVING, OR LIFE SUSTAINING APPLICATIONS, NOR IN PRODUCTS OR SYSTEMS WHERE FAILURE OR MALFUNCTION MAY RESULT IN PERSONAL INJURY, DEATH, OR SEVERE PROPERTY OR ENVIRONMENTAL DAMAGE. ST PRODUCTS WHICH ARE NOT SPECIFIED AS "AUTOMOTIVE GRADE" MAY ONLY BE USED IN AUTOMOTIVE APPLICATIONS AT USER'S OWN RISK.

Resale of ST products with provisions different from the statements and/or technical features set forth in this document shall immediately void any warranty granted by ST for the ST product or service described herein and shall not create or extend in any manner whatsoever, any liability of ST.

ST and the ST logo are trademarks or registered trademarks of ST in various countries.

Information in this document supersedes and replaces all information previously supplied.

The ST logo is a registered trademark of STMicroelectronics. All other names are the property of their respective owners.

© 2011 STMicroelectronics - All rights reserved

STMicroelectronics group of companies

Australia - Belgium - Brazil - Canada - China - Czech Republic - Finland - France - Germany - Hong Kong - India - Israel - Italy - Japan - Malaysia - Malta - Morocco - Philippines - Singapore - Spain - Sweden - Switzerland - United Kingdom - United States of America

www.st.com

