

Rev	AWO #	Description	Date	Appr
-		RELEASED	6/22/11	

APPROVED: \_\_\_\_\_  
 DATE: \_\_\_\_\_ TITLE: \_\_\_\_\_

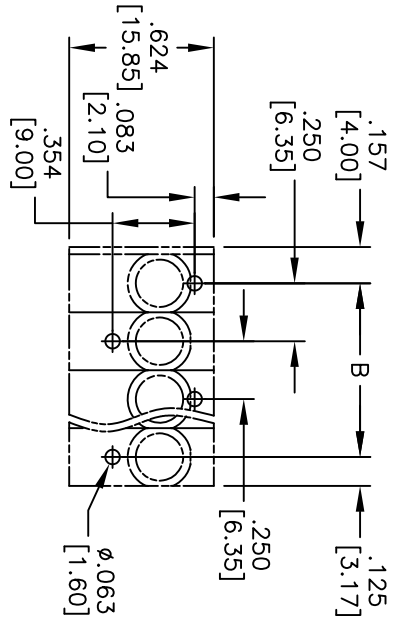

RECOMMENDED PCB LAYOUT

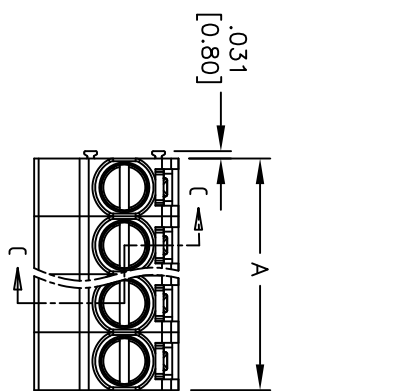
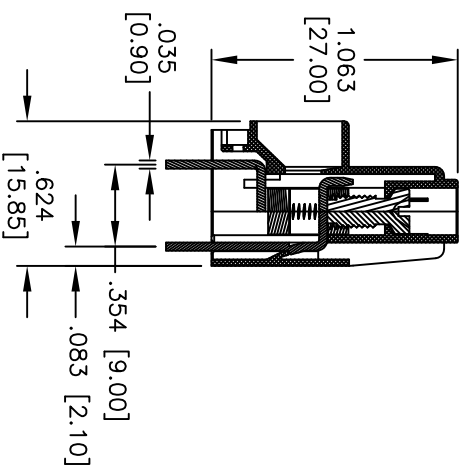
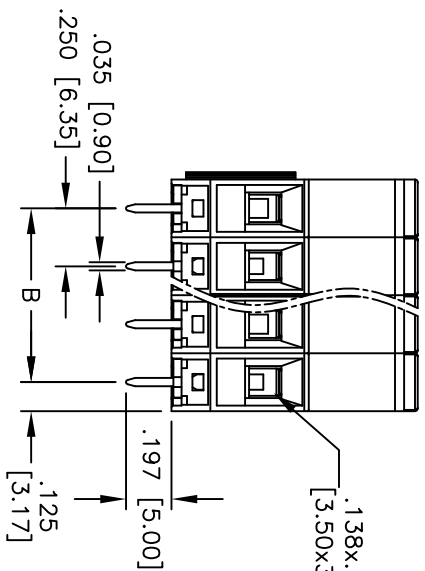

**SPECIFICATIONS:**

Material: Insulator: Thermoplastic, rated UL 94V-0  
 Insulator color: Green  
 Clamp: Brass, Nickel plated  
 Screw: M3.5, Steel, Zn plated.  
 Contact: Copper Alloy, Tin plated.

Electrical:  
 Operation voltage: 600 VAC  
 Current rating: 30 Amps

Mechanical:  
 Wire strip length: 8-9mm  
 Torque (lb-in): 5.2  
 Wire Range: 10-24 Awg  
 Withstanding Voltage: 2.2KV

Environmental:  
 Operating temperature: -40°C to +115°C  
 Lead free, ROHS compliant.  
 Recommended soldering temp: 235°C for 5 sec.



Poles: 2 thru 16  
 A = .250 [6.35] X No. of Positions  
 B = .250 [6.35] X No. of Spaces

UNLESS OTHERWISE SPECIFIED ALL DIMENSIONS ARE MM [INCHES] TOLERANCES: EXCEPT AS NOTED	
INCHES	HOLES
.X ± .10	± .10
.XX ± .020	± .015
.XXX ± .015	± .010
APPROVALS	
DATE	DATE
DRAWN	DY
6/22/11	
CHECKED	
APPROVED	

**ADAM TECH**  
 909 Rahway Avenue, Union, NJ 07083  
 Phone: 908-687-5000 Fax: 908-687-5710

TITLE: EURO BLOCK, .300 [7.62] PITCH

SIZE	PART NO.	REV.
X	EB122-XX-V	
REF: S00007T	SCALE: NTS	SHEET 1 OF 1